

FOR OFFICIAL USE



National
Qualifications
2022 MODIFIED

Mark

X844/75/02

Applications of Mathematics Paper 2

FRIDAY, 6 MAY

10:20 AM – 12:00 NOON



* X 8 4 4 7 5 0 2 *

Fill in these boxes and read what is printed below.

Full name of centre

Town

Forename(s)

Surname

Number of seat

Date of birth

Day

Month

Year

Scottish candidate number

Total marks — 55

Attempt ALL questions.

You may use a calculator.

To earn full marks you must show your working in your answers.

State the units for your answer where appropriate.

Write your answers clearly in the spaces provided in this booklet. Additional space for answers is provided at the end of this booklet. If you use this space you must clearly identify the question number you are attempting.

Use **blue** or **black** ink.

Before leaving the examination room you must give this booklet to the Invigilator; if you do not, you may lose all the marks for this paper.



* X 8 4 4 7 5 0 2 0 1 *

FORMULAE LIST

Circumference of a circle $C = \pi d$

Area of a circle $A = \pi r^2$

Theorem of Pythagoras

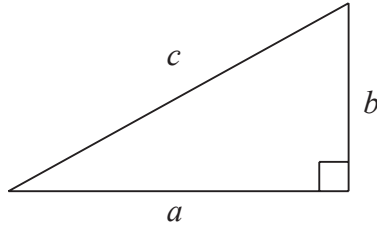

$$a^2 + b^2 = c^2$$

Volume of a cylinder $V = \pi r^2 h$

Volume of a prism $V = Ah$

Volume of a cone $V = \frac{1}{3} \pi r^2 h$

Volume of a sphere $V = \frac{4}{3} \pi r^3$

Standard deviation $s = \sqrt{\frac{\sum(x - \bar{x})^2}{n - 1}}$

or $s = \sqrt{\frac{\sum x^2 - \frac{(\sum x)^2}{n}}{n - 1}}$, where n is the sample size.

Gradient



$$\text{gradient} = \frac{\text{vertical height}}{\text{horizontal distance}}$$



Total marks — 55
 Attempt ALL questions

1. A soft drinks company currently have sales of 240 000 bottles per year.

It is predicted that sales will

- Decrease by 4.2% in the next year.
- Increase by 5.3% in each of the following 2 years.

Calculate the predicted sales after 3 years.

Give your answer to **3 significant figures**.

4

[Turn over



* X 8 4 4 7 5 0 2 0 3 *

2. The prices of lambs sold in September was recorded.
A sample of the prices, in pounds, is shown.

72 75 73 68 65 70

- (a) For these prices, calculate:

(i) the mean

1

(ii) the standard deviation.

3

The price of lambs sold in August was also recorded.

The mean price was £70.20 and the standard deviation was £3.85.

- (b) Make two valid comparisons about the prices of lambs in August and September.

2



3. Laura earns £40,560 per annum.

National Insurance is calculated on a person's salary **before** deductions such as pension contributions.

National Insurance rates	
Up to £9568	0%
From £9568 to £50,270	12%
Over £50,270	2%

Calculate her annual National Insurance payment.

2

[Turn over



* X 8 4 4 7 5 0 2 0 5 *

4. A company produces sandwiches and packs them in crates for transporting to shops.
 The dimensions of each sandwich box and the internal dimensions of a crate are shown in the diagrams. The filling label is placed on the top.

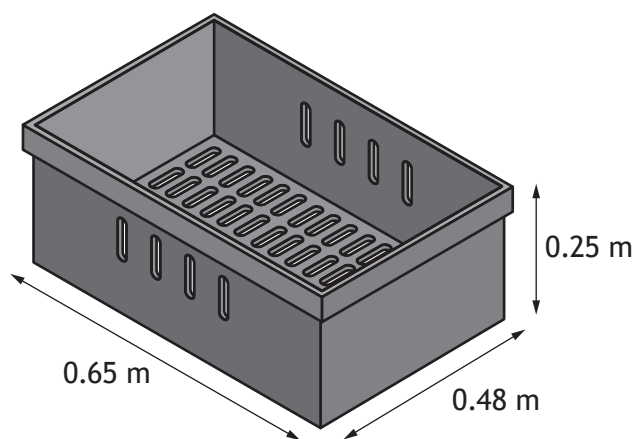
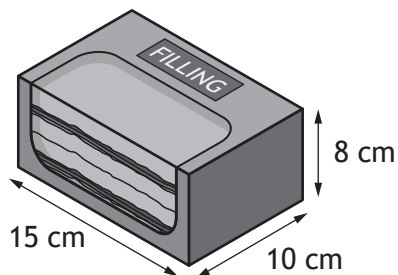

The sandwich boxes need to be laid with the filling label facing upwards. They must all be aligned in the same direction.

- (a) Calculate the maximum number of sandwich boxes that can be fitted into each crate.

3



4. (continued)

The company receives an order for 100 sandwiches.

It takes 7 employees 44 minutes to make 100 sandwiches.

All the employees work at the same rate.

(b) Calculate the time it would take 11 employees to make 100 sandwiches.

3

[Turn over



4. (continued)

Isaac sells sandwiches in his shop.

He spent a total of £92.65 on sandwiches, including delivery.

He then sold:

- 10 chicken salad sandwiches at £2.50 each
- 15 prawn mayo sandwiches at £3.20 each
- 9 egg mayo sandwiches at £1.95 each.

(c) Calculate the percentage loss Isaac made for this order.

3



4. (continued)

The table shows the cost of one box of sandwiches, in pounds.

Filling	Number of boxes of sandwiches ordered			
	0 to 9	10 to 19	20 to 29	30 or more
Tuna mayo	1.80	1.70	1.60	1.55
Chicken salad	1.95	1.85	1.75	1.65
Prawn mayo	2.30	2.20	2.10	2.05
Egg mayo	1.50	1.45	1.35	1.30
Ham and cheese	2.35	2.25	2.15	2.00

For each order, the company charges £2.75 per mile for delivery.

Yolanda's Sandwich Shop places an order for:

- 20 chicken salad
- 30 prawn mayo
- 15 egg mayo.

The distance travelled for the delivery is 6 miles.

(d) Calculate the total cost of this order.

3

[Turn over



5. An international athletics event was held in Doha, Qatar.
 In athletics, competitors in the heptathlon must compete in seven different events.
 The competitor is awarded points depending on how well they perform in each event.

The table shows the number of points awarded for different levels of performance in each of the events.

Points scored	Event						
	100 m Hurdles (sec)	High jump (m)	Shot put (m)	200 m run (sec)	Long jump (m)	Javelin throw (m)	800 m run (min sec)
980	13.99	1.81	16.77	24.01	6.42	56.15	2 min 9 sec
1000	13.85	1.82	17.07	23.80	6.48	57.18	2 min 8 sec
1020	13.71	1.83	17.37	23.59	6.54	58.25	2 min 6 sec
1040	13.57	1.85	17.66	23.39	6.60	59.25	2 min 5 sec
1060	13.43	1.86	17.95	23.19	6.66	60.30	2 min 4 sec
1080	13.30	1.88	18.25	22.99	6.72	61.30	2 min 2 sec
1100	13.16	1.89	18.54	22.79	6.78	62.30	2 min 1 sec
1120	13.03	1.91	18.84	22.59	6.84	63.35	2 min 0 sec
1140	12.90	1.92	19.14	22.40	6.90	64.39	1 min 59 sec
1160	12.76	1.95	19.43	22.20	6.96	65.40	1 min 57 sec
1180	12.63	1.96	19.72	22.01	7.02	66.40	1 min 56 sec
1200	12.51	1.97	20.02	21.82	7.08	67.45	1 min 55 sec

One of the competitors achieved a height of 1.95 metres in the high jump.

(a) Use the table to state how many points they scored for the high jump.

1



5. (continued)

The final event of the heptathlon is the 800 m run.

In this event, another of the competitors scored 1000 points.

- (b) By referring to the table, calculate this competitor's average speed over the 800 m run.

Give your answer in **metres per second**.

3

Lucy is a sports journalist.

She travelled to Doha to report on the international athletics event.

She flew from Manchester to Doha.

- Her flight landed in Doha at 19:18 local time.
- The flying time was 7 hours 23 minutes.
- Doha is 2 hours ahead of Manchester time.

- (c) Calculate the local time the flight left Manchester.

2

[Turn over



* X 8 4 4 7 5 0 2 1 1 *

5. (continued)

When she was in Qatar, Lucy stayed in a hotel.

She changed £1500 into Qatari riyals.

- She stayed for 8 nights.
- The room rate was 418 Qatari riyals per night.
- She spent 1836 Qatari riyals on other expenses.
- She then changed all her remaining Qatari riyals into euros.

The rates of exchange were:

Currency exchange	
Pounds sterling (£)	Other currencies
1	4.67 Qatari riyals
1	1.16 euros

(d) Calculate how many euros Lucy received.

4



6. Pepe inspects and sells fire extinguishers.

His monthly gross pay consists of a basic wage plus commission on the sale of any fire extinguishers.

The rate of commission he earns depends on the mean price he sells each fire extinguisher for, as shown.

Mean price of fire extinguisher	Rate of commission
£40–£49.99	14%
£50–£59.99	14.5%
£60–£69.99	15%
£70–£79.99	15.5%
£80–£89.99	16%
£90–£99.99	16.5%

In January, Pepe's basic wage was £1200.

He sold 107 fire extinguishers for a total of £8185.50.

- (a) Calculate Pepe's gross pay for the month of January.

3

Pepe sells three different types of fire extinguishers.

In February he sold water, foam and powder fire extinguishers in the ratio 6:2:7 respectively.

He sold 56 powder fire extinguishers in February.

- (b) Calculate the total number of fire extinguishers he sold in February.

2

[Turn over



6. (continued)

A customer wants to buy 12 powder fire extinguishers and 12 stands.

- The recommended price of one powder fire extinguishers is £78.
- The recommended price of one stand is £15.

The customer saw the following deals available.

Company A	Company B	Company C
Buy 2 powder fire extinguishers, get one free. All stands reduced by £2.50.	$\frac{1}{6}$ off the recommended price of all fire extinguishers. Each fire extinguisher comes with a free stand.	12 powder fire extinguishers and 12 stands for £900.

To encourage the customer to buy from him instead, Pepe offers a 5% discount on the cheapest of these deals.

- (c) Calculate how much Pepe will charge the customer.

3



6. (continued)

Pepe inspected the fire extinguishers of a local business.

The fire extinguishers were considered safe if they weighed $10.4 \text{ kg} \pm 10\%$.

The weights, in kilograms, of the fire extinguishers inspected are shown.

9.80, 11.67, 9.12, 10.94, 11.10, 9.27, 10.55

- (d) Calculate the maximum and minimum safe weights and determine the fraction that were considered safe.

3

[Turn over



7. Jamel keeps fish.

To make tap water safe for fish, a conditioner is added.

The volume of conditioner required is directly proportional to the volume of tap water.

5 ml of conditioner must be used for every 20 000 ml of tap water.

(a) Calculate the volume of conditioner required for 14 litres of tap water.

2



* X 8 4 4 7 5 0 2 1 6 *

7. (continued)

Jamel has a fish tank.

The fish tank is a cuboid with dimensions 30 cm by 30 cm by 42 cm.

The tank has a cylindrical light box at the bottom as shown.

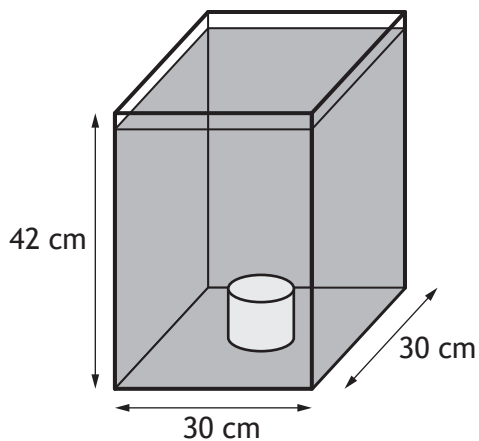

The cylindrical light box has a diameter of 10 cm and a height of 8 cm.

There is a 2 cm gap between the top of the tank and the water level.

The light box **does not** hold any water.

(b) Calculate the volume of water in the tank.

4

[Turn over



7. (continued)

Jamel bought a stand for this fish tank.

The top of the stand is circular.

The corners of the square base of the tank touch the edge of the circle as shown.

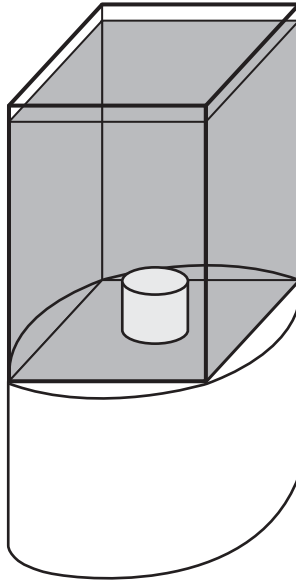

The diameter of the circle is shown by the dotted line in the aerial view.

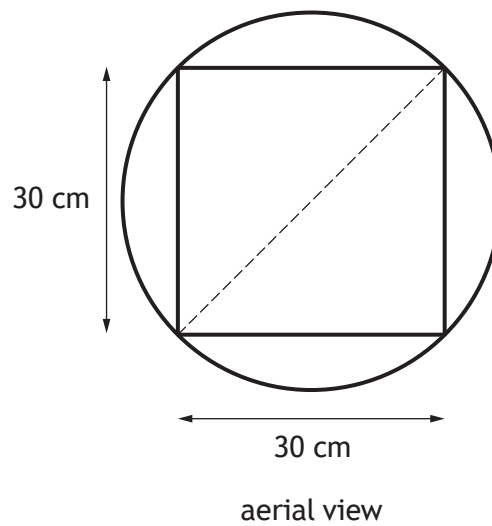

7. (continued)

- (c) Calculate the area of the top of the stand.
Give your answer in **square metres**.

4

[END OF QUESTION PAPER]



* X 8 4 4 7 5 0 2 1 9 *

MARKS DO NOT
WRITE IN
THIS
MARGIN

ADDITIONAL SPACE FOR ANSWERS



MARKS DO NOT
WRITE IN
THIS
MARGIN

ADDITIONAL SPACE FOR ANSWERS



* X 8 4 4 7 5 0 2 2 1 *

MARKS DO NOT
WRITE IN
THIS
MARGIN

ADDITIONAL SPACE FOR ANSWERS



* X 8 4 4 7 5 0 2 2 2 *

[BLANK PAGE]

DO NOT WRITE ON THIS PAGE



* X 8 4 4 7 5 0 2 2 3 *

[BLANK PAGE]

DO NOT WRITE ON THIS PAGE



* X 8 4 4 7 5 0 2 2 4 *