



National
Qualifications
2018

2018 Chemistry

National 5

Finalised Marking Instructions

© Scottish Qualifications Authority 2018

The information in this publication may be reproduced to support SQA qualifications only on a non-commercial basis. If it is reproduced, SQA should be clearly acknowledged as the source. If it is to be used for any other purpose, written permission must be obtained from permissions@sqa.org.uk.

Where the publication includes materials from sources other than SQA (secondary copyright), this material should only be reproduced for the purposes of examination or assessment. If it needs to be reproduced for any other purpose it is the centre's responsibility to obtain the necessary copyright clearance. SQA's NQ Assessment team may be able to direct you to the secondary sources.

These marking instructions have been prepared by examination teams for use by SQA appointed markers when marking external course assessments. This publication must not be reproduced for commercial or trade purposes.



General marking principles for National 5 Chemistry

This information is provided to help you understand the general principles you must apply when marking candidate responses to questions in this paper. These principles must be read in conjunction with the detailed marking instructions, which identify the key features required in candidate responses.

- (a) Marks for each candidate response must always be assigned in line with these general marking principles and the detailed marking instructions for this assessment.
- (b) If a specific candidate response does not seem to be covered by either the principles or detailed marking instructions, and you are uncertain how to assess it, you must seek guidance from your team leader.
- (c) Marking should always be positive. This means that, for each candidate response, marks are accumulated for the demonstration of relevant skills, knowledge and understanding: they are not deducted from a maximum on the basis of errors or omissions.

A guiding principle in marking is to give credit for correct chemistry rather than to look for reasons not to award marks.

Example 1: The structure of a hydrocarbon found in petrol is shown below.

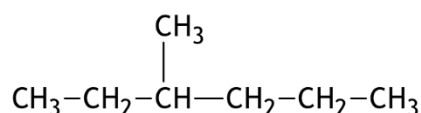

Name the hydrocarbon.

Although the punctuation is not correct, '3, methyl-hexane' should gain the mark.

Example 2: A student measured the pH of four carboxylic acids to find out how their strength is related to the number of chlorine atoms in the molecule.

The results are shown in the table.

<i>Structural formula</i>	<i>pH</i>
CH ₃ COOH	1.65
CH ₂ ClCOOH	1.27
CHCl ₂ COOH	0.90
CCl ₃ COOH	0.51

State how the strength of the acids is related to the number of chlorine atoms in the molecule.

Although not completely correct, an answer such as 'the more Cl₂, the stronger the acid' should gain the mark.

- (d) There are no half marks awarded.
- (e) Candidates must respond to the 'command' word as appropriate and may be required to write extended answers in order to communicate fully their knowledge and understanding.

- (f) Marks should be awarded for answers that have incorrect spelling or loose language **as long as the meaning of the word(s) is conveyed**. **Example:** Answers like ‘distilling’ (for ‘distillation’) and ‘it gets hotter’ (for ‘the temperature rises’) should be accepted.

However, the example below would not be given any credit, as an incorrect chemical term, which the candidate should know, has been given.

Example: If the correct answer is ‘ethene’, and the candidate’s answer is ‘ethane’, this should not be accepted.

- (g) A correct answer followed by a wrong answer should be treated as a cancelling error and no marks should be awarded.

Example: State what colour is seen when blue Fehling’s solution is warmed with an aldehyde.

The answer ‘red, green’ gains no marks.

If a correct answer is followed by additional information which does not conflict, the additional information should be ignored, whether correct or not.

Example: State why the tube cannot be made of copper.

If the correct answer is related to a low melting point, ‘Copper has a low melting point and is coloured grey’ would not be treated as having a cancelling error.

- (h) Unless a numerical question specifically requires evidence of working to be shown, full marks should be awarded for a correct final answer (including units if required) on its own.

The partial marks shown in the marking scheme are for use when working is given but the final answer is incorrect. An exception is when candidates are asked to ‘Find, by calculation’, when full marks cannot be awarded for the correct answer without working.

- (i) In most questions units are not required. However, if the candidate writes units then they must be correct. An incorrect unit would not be acceptable and one mark would not be awarded.

This marking instruction must only be applied a maximum of once per paper.

- (j) Where the marking instructions specifically allocate a mark for units in a calculation, this mark should not be awarded if the units are incorrect or missing. Missing or incorrect units at intermediate stages in a calculation should be ignored.

- (k) As a general rule, where a wrong numerical answer (already penalised) is carried forward to another step, credit will be given provided the result is used correctly. The exception to this rule is where the marking instructions for a numerical question assign separate ‘concept marks’ and an ‘arithmetic mark’. In such situations, the marking instructions will give clear guidance on the assignment of partial marks.

- (l) Ignore the omission of one H atom from a full structural formula provided the bond is shown or one carbon to hydrogen bond missing provided the hydrogen is shown.

- (m) A symbol or correct formula should be accepted in place of a name **unless stated otherwise in the marking instructions**.

- (n) When formulae of ionic compounds are given as answers it will only be necessary to show ion charges if these have been specifically asked for. However, if ion charges are shown, they must be correct. If incorrect charges are shown, no marks should be awarded.

- (o) If an answer comes directly from the text of the question, no marks should be awarded.

Example: A student found that 0.05 mol of propane, C₃H₈ burned to give 82.4 kJ of energy.

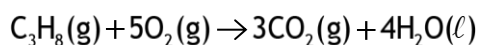

Name the type of enthalpy change which the student measured.

No marks should be awarded for 'burning' since the word 'burned' appears in the text.

- (p) Unless the question is clearly about a non-chemistry issue, eg costs in industrial chemical process, a non-chemical answer gains no marks.

Example: Suggest why the (catalytic) converter has a honeycomb structure.

A response such as 'to make it work' may be correct but it is not a chemical answer and the mark should not be awarded.

Marking instructions for each question

Section 1

Question	Answer	Mark
1.	A	1
2.	B	1
3.	B	1
4.	D	1
5.	A	1
6.	D	1
7.	C	1
8.	B	1
9.	C	1
10.	D	1
11.	C	1
12.	C	1
13.	A	1
14.	B	1
15.	B	1
16.	C	1
17.	A	1
18.	B	1
19.	A	1
20.	C	1
21.	C	1
22.	D	1
23.	D	1
24.	B	1
25.	D	1

Section 2

Question		Expected response	Max mark	Additional guidance
1.	(a)	Carbon dioxide	1	Accept correct formula CO ₂ . Do not accept CO ₂ , CO ² .
	(b) (i)	<p>0.5 or $\frac{1}{2}$ cm³s⁻¹ (3 marks)</p> <hr/> <p>Partial marking:</p> <p>0.5 with no unit/incorrect unit (2 marks)</p> <p>OR</p> <p>1 mark awarded for concept of change in volume/change in time.</p> <p>$\frac{77-62}{50-20}$ or $\frac{15}{30}$ or $\frac{62-77}{20-50}$ (1 mark)</p> <hr/> <p>Correct unit cm³s⁻¹ (1 mark) This mark is independent of the calculated value.</p>	3	<p>Accept cm³/s or unit in words.</p> <p>Do not accept cm³/s⁻¹ or sec.</p> <p>The mark for a final answer can only be awarded if the concept of change in volume/change in time is correct ie incorrect values from the table used (subtractions must be shown and volumes chosen must correspond to chosen times).</p>
	(ii)	<p>One mark is awarded for a graph which shows points plotted rather than bars. (1 mark)</p> <p>The axis/axes of the graph has/have suitable scale(s). For the graph paper provided within the question paper, the selection of suitable scales will result in a graph (plotted points) that occupies at least half of the width and half of the height of the graph paper. (1 mark)</p> <p>The axes of the graph have suitable labels and units. (1 mark)</p> <p>All data points plotted accurately (within a half box tolerance) with either a line of best fit drawn or plots joined. This mark can only be accessed if linear scales for both axes have been provided. (1 mark)</p>	4	<p>Where the candidate has drawn a bar graph the mark for the correct type of graph is not awarded, but the remaining three marks can still be accessed.</p> <p>For bar graphs, this mark is awarded for the selection of a suitable scale.</p> <p>Spelling mistakes or the use of abbreviations should not be penalised if the meaning of an axis label may be clearly understood.</p> <p>Where the candidate has drawn a bar graph, the mark for accurate plotting can be awarded if the heights of bars are plotted accurately but in this case no line of best fit is required.</p>

Question			Expected response	Max mark	Additional guidance
1.	(b)	(iii)	<p>Answer must be correct for the candidate's graph (within a half box tolerance).</p> <p>If no graph drawn, 68 ± 1.</p>	1	<p>Unit is not required; however zero marks are awarded for the correct value with incorrect unit.</p> <p>This marking instruction must only be applied a maximum of once per paper.</p>
	(c)		<p>Greater number / concentration / moles of hydrogen ions / H^+</p> <p>OR</p> <p>more H^+ ions.</p>	1	<p>Award zero marks for 'more hydrogen' / more hydrogen atoms / more 'H' / more acid / more moles of acid.</p> <p>Award zero marks for mention of stronger/weaker acid but this does not negate a correct answer.</p>

Question			Expected response	Max mark	Additional guidance
2.	(a)	(i)	Addition	1	Award one mark for 'additional'.
		(ii)	$ \begin{array}{cccccc} \text{F} & \text{F} & \text{F} & \text{F} & \text{F} & \text{F} \\ & & & & & \\ \text{---C} & \text{---C} & \text{---C} & \text{---C} & \text{---C} & \text{---C} \text{---} \\ & & & & & \\ \text{F} & \text{F} & \text{F} & \text{F} & \text{F} & \text{F} \end{array} $	1	<p>Mark can still be awarded if one end bond is missing.</p> <p>Allow dot or ~ to represent end bond.</p> <p>Ignore the omission of one F atom provided the bond is shown or one carbon to fluorine bond missing provided the fluorine is shown.</p> <p>Zero marks awarded if</p> <ul style="list-style-type: none"> • both end bonds are missing • less than or more than three monomers shown • a bond between two carbons is missing.
	(b)		Correctly drawn full structural formula for ethene.	1	Do not accept the word ethene on its own but it does not negate a correct answer.

Question		Expected response	Max mark	Additional guidance
3.	(a)	<p>As the percentage of carbon increases the heat content also increases.</p> <p>OR</p> <p>As the percentage of carbon decreases the heat content also decreases.</p> <p>OR</p> <p>The heat content increases as the percentage of carbon increases.</p> <p>OR</p> <p>The heat content decreases as the percentage of carbon decreases.</p>	1	<p>Zero marks awarded for an incorrect cause and effect eg as the heat content increases the percentage of carbon increases.</p> <p>Zero marks awarded if the candidate uses the word coal instead of carbon.</p>
	(b)	<p>46.67 / 46.7 / 47 (%) (3 marks)</p> <p>-----</p> <p>Partial marking:</p> <p>$GFM = 120$ (1 mark)</p> <p>$\frac{56}{\text{candidate's } GFM} \times 100$ (1 mark)</p> <p>This step on its own is worth 2 marks if the candidate's gfm is 120.</p> <p>Calculation of final answer using the relationship</p> <p>$\% \text{ by mass} = \frac{m}{GFM} \times 100$ (1 mark)</p>	3	<p>Award zero marks for 46/46.6 (%) with no working shown.</p> <p>Unit is not required, however a maximum of 2 marks can be awarded for the correct value with incorrect unit.</p> <p>This marking instruction must only be applied a maximum of once per paper.</p> <p>The mark for the final answer can only be awarded if the correct relationship between total mass of element present divided by gfm x 100 is shown with working.</p>

Question		Expected response	Max mark	Additional guidance
4.	(a)	Hydrogen and carbon.	1	Accept H/H ₂ /C
	(b)	Methylpropane OR 2-methylpropane	1	Omission of a hyphen should not be penalised.
	(c)	Stronger and intermolecular forces.	1	Both phrases correctly circled.
	(d)	150 to 154°C inclusive.	1	Unit is not required; however zero marks are awarded for the correct value with incorrect unit. This marking instruction must only be applied a maximum of once per paper.

Question		Expected response	Max mark	Additional guidance
5.	(a)	Sodium azide, potassium nitrate and silicon dioxide.	1	Correct formulae accepted.
	(b)	Potassium oxide.	1	Correct formula accepted.
	(c)	SiO ₂	1	Do not accept Si ₂ O ₄ .
	(d)	44 (litres)	1	Unit is not required; however zero marks can be awarded for the correct value with incorrect unit. This marking instruction must only be applied a maximum of once per paper.

Question			Expected response	Max mark	Additional guidance
6.	(a)	(i)	Two	1	
		(ii)	10.8 (2 marks) 11 with working (2 marks) ----- Partial marking: $\frac{(10 \times 20) + (11 \times 80)}{100}$ (1 mark) OR $\frac{10 \times 20\% + 11 \times 80\%}{100}$ (1 mark)	2	Award zero marks for 11 on its own. Accept amu/g Unit is not required; however a maximum of 1 mark can be awarded for the correct value with incorrect unit. This marking instruction must only be applied a maximum of once per paper.
	(b)		${}^{14}_6\text{C}$	1	

Question		Expected response	Max mark	Additional guidance
7.	(a)	(Ionic) Lattice	1	Any mention of covalent/network/metallic negates Award zero marks for crystal on its own but it does not negate the correct answer.
	(b)	(i)	1	Award zero marks for electrons/molecules/charged particles in place of ions.
		(ii)	1	
		(iii)	1	Award zero marks for <ul style="list-style-type: none"> allows ions to separate so each electrode stays the same charge so the electricity/current goes in the one direction.
		Allows the product(s) to be identified. OR To make sure that only one product is produced at each electrode. OR To separate the strontium from the chlorine.		

Question	Expected response	Max mark	Additional guidance
8.	<p>This is an open ended question.</p> <p>1 mark: The student has demonstrated a limited understanding of the chemistry involved. The candidate has made some statement(s) which is/are relevant to the situation, showing that at least a little of the chemistry within the problem is understood.</p> <p>2 marks: The student has demonstrated a reasonable understanding of the chemistry involved. The student makes some statement(s) which is/are relevant to the situation, showing that the problem is understood.</p> <p>3 marks: The maximum available mark would be awarded to a student who has demonstrated a good understanding of the chemistry involved. The student shows a good comprehension of the chemistry of the situation and has provided a logically correct answer to the question posed. This type of response might include a statement of the principles involved, a relationship or an equation, and the application of these to respond to the problem. This does not mean the answer has to be what might be termed an “excellent” answer or a “complete” one.</p>	3	

Question			Expected response	Max mark	Additional guidance
9.	(a)	(i)	(A molecule that contains) carbon to carbon double bond. OR C=C	1	Award zero marks for a double bond without mention of carbon. Award zero marks for alkene but does not negate a correct answer. Accept carbon to carbon triple bond. If the candidate draws the structure of an unsaturated molecule they must highlight the carbon to carbon double/triple bond.
		(ii)	Bromine (solution)(water)/Br ₂ decolourised/discoloured/goes colourless.	1	Award zero marks for bromide or Br or Br ⁻ . Award zero marks for 'goes clear' however if given in addition to a correct answer it does not negate. If starting colour is given it must be correct eg orange/yellow/red-brown or brown. Award zero marks if the candidate implies it is the olive oil that is being decolourised. Ignore any mention of time frame.
	(b)		472.8 / 473 (kJ) (3 marks) ----- Partial marking: Using $cm\Delta T$ with $c = 1.97$ (1 mark) To be awarded this concept mark, candidates do not specifically need to write $cm\Delta T$. The concept mark is awarded for using this relationship with three values, one of which must be 1.97. For values 1.5 (kg) and 160 (°C) (1 mark) A further mark can be awarded for arithmetical follow through to the candidate's answer only if the mark for the $cm\Delta T$ concept has been awarded. (1 mark)	3	3 marks can be awarded for 472800 or 473000 J. However the unit (Joules / J) must be given. Unit is not required if answer given in kilojoules, however a maximum of 2 marks can be awarded for the correct value with incorrect unit. This marking instruction must only be applied a maximum of once per paper. If the candidate uses the values of 1.97 and 4.18 the concept mark cannot be awarded. A maximum of 1 mark can be awarded for the values of 1.5 and 160.

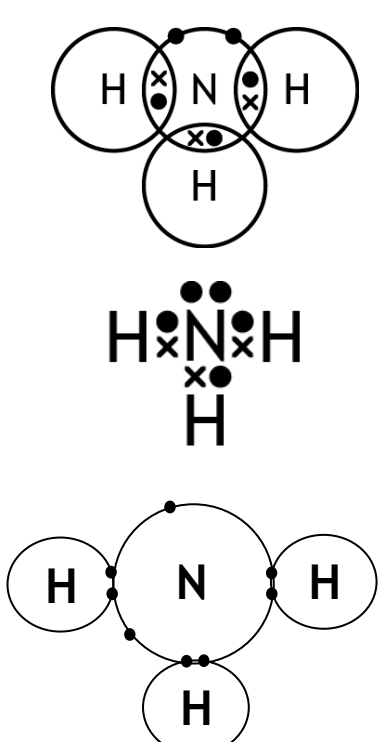
Question			Expected response	Max mark	Additional guidance
10.	(a)	(i)	$\text{N}_2 + 3\text{H}_2 \rightleftharpoons 2\text{NH}_3$	1	Accept correct multiples.
		(ii)	The reaction (it) is reversible OR the reaction (it) occurs in both directions OR the reaction (it) reaches (or is at) equilibrium.	1	
	(b)		Diagram showing nitrogen with three hydrogen atoms: each of the three overlap areas must have two electrons in or on overlap area. Either the nitrogen or all three hydrogen symbols must be shown. 	1	The diagram does not need to show trigonal pyramidal shape. Accept cross or dot or e or e- to represent electrons or a mixture of these. Accept petal diagram. The non-bonding electrons in nitrogen must be shown but do not need to be together/shown as a pair. Bonding electrons MUST be on the line or in the overlapping area. If inner electrons on nitrogen are shown they must be correct ie 2.
	(c)		Ostwald	1	Award zero marks for catalytic oxidation but does not negate a correct answer.
	(d)		Ammonium nitrate	1	Accept the correct formula.

Question		Expected response	Max mark	Additional guidance
11.	(a)	From Mg to Cu through meter/wire.	1	Award zero marks for <ul style="list-style-type: none"> • arrow goes into solution • arrow is drawn on wire and ion bridge • arrow is drawn closer to the ion bridge than the wire/ammeter.
	(b)	Completes the circuit/cell OR allows ions to flow/move/transfer (between the two beakers) OR provide ions to complete the circuit /cell.	1	Award zero marks for allows electrons to flow and this negates a correct answer. Award zero marks for allows the current to flow but this does not negate a correct answer.
	(c)	$\text{Cu}^{2+}(\text{aq}) + 2\text{e}^{-} \longrightarrow \text{Cu}(\text{s})$	1	State symbols are not required, however if given they must be correct.
	(d)	Insoluble OR Solubility less than 1 g l^{-1}	1	Award zero marks for “phosphate is insoluble”.

Question		Expected response	Max mark	Additional guidance
12.	(a)	(Alpha particles) they <ul style="list-style-type: none"> cannot penetrate the paper cannot pass through paper are stopped by the paper are absorbed by the paper can only pass through air. 	1	Award zero marks for <ul style="list-style-type: none"> they do not travel far they cannot reach the detector air absorbs alpha particles. However they do not negate a correct answer.
	(b)	14·8 (years) (2 marks) ----- Partial marking: 1 mark can be awarded for either : <ul style="list-style-type: none"> 4 half-lives OR <ul style="list-style-type: none"> number of years correctly calculated for an incorrect number of half-lives (provided the working supports the number of half-lives). 	2	Unit is not required; however a maximum of 1 mark can be awarded for the correct value with incorrect unit. This marking instruction must only be applied a maximum of once per paper.
	(c)	Increases Stays the same	1	Both required for 1 mark.

Question			Expected response	Max mark	Additional guidance
13.	(a)	(i)	Carboxyl	1	Award zero marks for carboxylic (acid).
		(ii)	134(g)	1	Unit is not required; however 0 marks can be awarded for the correct value with incorrect unit. This marking instruction must only be applied a maximum of once per paper.
	(b)		Any correct statement linking acidity to the position of the halogen. eg The acidity (of the carboxylic acids) decreases going down the group. OR As you go (up) from iodine to fluorine the acidity increases. OR The one at the top (of the group) has the highest acidity. OR The one that has the lowest acidity is at the bottom (of the group).	1	Award zero marks for an explanation in terms of pH only rather than acidity however this does not negate a correct answer. Award zero marks for stronger/weaker acid but does not negate a correct answer. The term increase/decrease on its own does not clearly indicate the position of halogen in the group.
	(c)		A correct shortened or full structural formula for 4-methylpentanoic acid eg $\text{CH}_3\text{CH}(\text{CH}_3)\text{CH}_2\text{CH}_2\text{COOH}$ $\text{HOOCCH}_2\text{CH}_2\text{CH}(\text{CH}_3)\text{CH}_3$ $ \begin{array}{cccccc} & \text{OH} & \text{H} & \text{H} & \text{H} & \text{H} \\ & & & & & \\ \text{O}=\text{C} & -\text{C} & -\text{C} & -\text{C} & -\text{C} & -\text{H} \\ & & & & \\ & \text{H} & \text{H} & \text{H} & \text{H} \\ & & & \text{H}-\text{C}-\text{H} \\ & & & \\ & & & \text{H} \end{array} $ OR mirror images.	1	Accept CH_3 for branch in a full structural formula.

Question		Expected response	Max mark	Additional guidance	
14.	(a)	C OR 0.24	1	Accept C or 0.24 identified in table.	
	(b)	(i)	Pipette	1	
		(ii)	(2 and 4) They are concordant. OR They are within 0.2 (cm ³). OR They are within 0.1 / 0.1 apart. OR Titration 1 and 3 or the other two are not concordant or not within 0.2 of each other.	1	Award zero marks for any of the following on their own but these answers do not negate a correct answer. <ul style="list-style-type: none"> • They are the most accurate/consistent. • They are really close together. • They are the closest to each other. • They are the closest to 8.05. • Those are the two that gives the average. • Titrations 1 and 3 are rough.
		(iii)	0.000161 (mol / mole / moles) OR 1.61×10^{-4}	1	Unit is not required; however 0 marks can be awarded for the correct value with incorrect unit. This marking instruction must only be applied a maximum of once per paper.

Question			Expected response	Max mark	Additional guidance
15.	(a)		Diamond(s) anvil cell	1	
	(b)	(i)	1.9 million (atmospheres) OR 1 900 000 (atmospheres) OR 1.9×10^6	1	Unit is not required; however 0 marks can be awarded for the correct value with incorrect unit. This marking instruction must only be applied a maximum of once per paper.
		(ii)	The bulb would not light/would turn off.	1	Award zero marks for <ul style="list-style-type: none"> • electricity does not flow • does not conduct electricity. However, they do not negate the correct answer. Additional incorrect chemistry negates a correct answer eg metals don't conduct electricity when solid.
	(c)		$\text{Fe}_2\text{O}_3 \rightarrow \text{O}_2 + \text{Fe}_5\text{O}_7$	1	Does not require to be balanced. If balanced it must be correct ie $5\text{Fe}_2\text{O}_3 \rightarrow \frac{1}{2} \text{O}_2 + 2\text{Fe}_5\text{O}_7$ or correct multiples. Ignore state symbols if given. Award zero marks for an equals sign in place of an arrow.

Question			Expected response	Max mark	Additional guidance
16.	(a)	(i)	Homologous (series)	1	Award zero marks for homogeneous.
		(ii)	$C_nH_{2n+1}SH$ / $C_nH_{2n+1}HS$ OR C_nSH_{2n+2} OR $C_nH_{2n+2}S$ OR $C_nH_{2(n+1)}S$	1	Accept n or x Award zero marks for $C_nH_{2n+1}S + H$ $C_nH_{2n+1}SH$ $C_nH_{2n+1}SH_n$.
	(b)		Sulfur (mon)oxide Sulfur dioxide Sulfur trioxide	1	Accept a correct formula.

Question		Expected response	Max mark	Additional guidance
16.	(c)	<p>960 (g) (3 marks)</p> <p>-----</p> <p>Partial marking:</p> <p>Both GFM's 32 and 48 (1 mark)</p> <p>OR</p> <p>correct number of moles of methanol (20 moles). (1 mark)</p> <p>-----</p> <p>Correct application of the relationship between moles and mass. (1 mark)</p> <p>This could be shown by:</p> <p>Method A</p> <p><i>moles CH₃SH</i> × <i>candidate's GFM CH₃SH</i></p> <p>OR</p> <p>Method B</p> <p>by working showing correct proportionality.</p> $640 \leftrightarrow \frac{\text{candidate GFM CH}_3\text{SH}}{\text{candidate GFM CH}_3\text{OH}} \times 640$ <p>Where the candidate has been awarded the mark for the correct application of the relationship between moles and mass, a further mark can be awarded for correct follow through to a final answer. (1 mark)</p> <p>OR</p> <p>Any other valid method accepted.</p>	3	<p>Unit is not required, however a maximum of 2 marks can be awarded for the correct value with incorrect unit.</p> <p>A maximum of two marks can be awarded where the candidate has carried out the calculation using methanol and one wrong chemical provided working is shown. ie</p> <p>if a candidate calculates the mass of H₂S or H₂O instead of methanethiol a maximum of 2 marks can be awarded for 680 (g) for using H₂S and 360 (g) for using H₂O provided the gfm of each of these chemicals is correct.</p> <p>Award zero marks if candidate's working does not use methanol.</p>

Question	Expected response	Max mark	Additional guidance
17.	<p>1 mark: The student has demonstrated a limited understanding of the chemistry involved. The candidate has made some statement(s) which is/are relevant to the situation, showing that at least a little of the chemistry within the problem is understood.</p> <p>2 marks: The student has demonstrated a reasonable understanding of the chemistry involved. The student makes some statement(s) which is/are relevant to the situation, showing that the problem is understood.</p> <p>3 marks: The maximum available mark would be awarded to a student who has demonstrated a good understanding of the chemistry involved. The student shows a good comprehension of the chemistry of the situation and has provided a logically correct answer to the question posed. This type of response might include a statement of the principles involved, a relationship or an equation, and the application of these to respond to the problem. This does not mean the answer has to be what might be termed an “excellent”.</p>	3	

[END OF MARKING INSTRUCTIONS]