



National
Qualifications
2019

X813/75/02

**Chemistry
Section 1 — Questions**

FRIDAY, 10 MAY

1:00 PM – 3:30 PM

Instructions for the completion of Section 1 are given on *page 02* of your question and answer booklet X813/75/01.

Record your answers on the answer grid on *page 03* of your question and answer booklet.

You may refer to the Chemistry Data Booklet for National 5.

Before leaving the examination room you must give your question and answer booklet to the Invigilator; if you do not, you may lose all the marks for this paper.



* X 8 1 3 7 5 0 2 *

SECTION 1 — 25 marks

Attempt ALL questions

Questions 1 and 2 refer to an experiment to investigate the rate of a reaction.

The volume of gas collected in 2 minutes was 5 cm^3 .

1. What was the average rate of reaction over this time?
 - A 0.2
 - B 0.4
 - C 2.5
 - D 5.0

2. The unit for the average rate of this reaction is
 - A $\text{cm}^3/\text{min}^{-1}$
 - B $\text{cm}^3 \text{ min}^{-1}$
 - C min/cm^3
 - D min cm^{-3}

3. Tennessine is a newly discovered element with a predicted electron arrangement of 2,8,18,32,32,18,7.

In which group of the periodic table should Tennessine be placed?

 - A 1
 - B 2
 - C 7
 - D 8

4. Which of the following is a positively charged ion?

	Protons	Neutrons	Electrons
A	9	10	10
B	10	9	10
C	11	12	11
D	12	13	10

5. To turn a gas into a liquid it must be cooled below a temperature known as its critical temperature.

Gas	Formula	Relative formula mass	Critical temperature (°C)
hydrogen	H ₂	2	-240
helium	He	4	-268
ammonia	NH ₃	17	133
oxygen	O ₂	32	-119
carbon dioxide	CO ₂	44	31

Identify the true statement based on the information in this table.

- A Carbon dioxide can be a liquid at 40 °C
 - B Compounds have higher critical temperatures than elements
 - C Critical temperature increases as relative formula mass increases
 - D Diatomic elements have lower critical temperatures than Noble gases
6. A molecule of phosphorus trifluoride is shown.



Which term can be used to describe the shape of a phosphorus trifluoride molecule?

- A Linear
- B Angular
- C Tetrahedral
- D Trigonal pyramidal

[Turn over

7. In which of the following compounds do the ions have the same electron arrangement?
You may wish to use the data booklet to help you.

- A Na_2O
- B LiF
- C KBr
- D MgCl_2

8. Several conductivity experiments were carried out using the apparatus below.

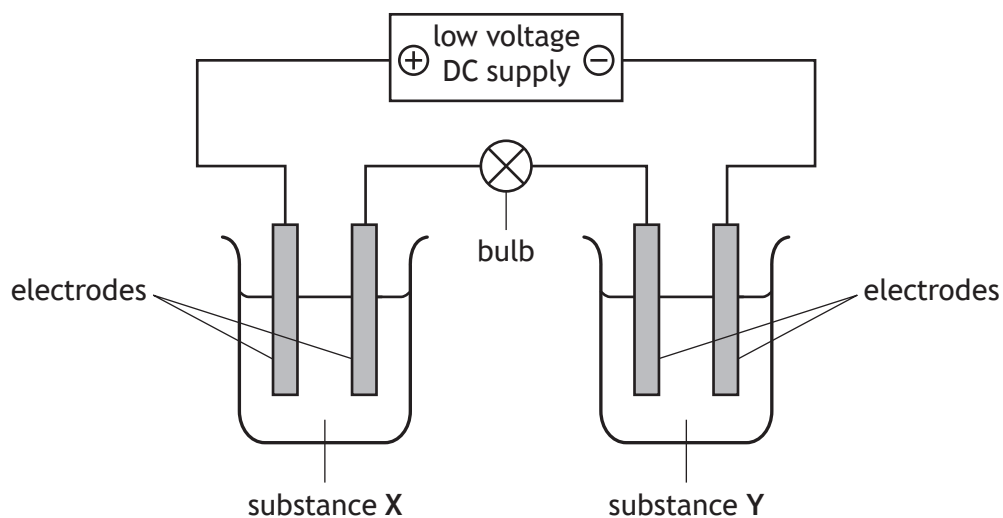

Identify the experiment in which the bulb would light.

	Substance X	Substance Y
A	solid copper sulfate	liquid mercury
B	copper chloride solution	molten sodium chloride
C	solid potassium nitrate	nickel bromide solution
D	sodium chloride solution	liquid hexane

9. Limewater can be made by dissolving calcium hydroxide in water.
Which of the following terms correctly describes calcium hydroxide?

- A Solute
- B Solvent
- C Solution
- D Insoluble

10. Ammonium nitrate, NH_4NO_3 , has a gram formula mass of 80.
The percentage by mass of nitrogen in ammonium nitrate is equal to

- A $\frac{14}{80} \times 100$
- B $\frac{28}{80} \times 100$
- C $\frac{28}{100} \times 80$
- D $\frac{80}{28} \times 100$.

11. As an alkaline solution is diluted with water

- A the pH increases
- B the pH stays the same
- C the concentration of hydroxide ions increases
- D the concentration of hydroxide ions decreases.

12. Which of the following compounds is a base?

- A Sodium oxide
- B Calcium chloride
- C Potassium nitrate
- D Ammonium sulfate

[Turn over

13. Which of the following compounds does **not** have an isomer?

- A Cyclopropane
- B But-1-ene
- C Pentane
- D Ethene

14. The systematic name for $\text{CH}_3\text{CH}_2\text{C}(\text{CH}_3)\text{CHCH}_3$ is

- A 3-methylpentane
- B 2-methylpentane
- C 3-methylpent-2-ene
- D 2-methylpent-3-ene.

15. When pent-1-ene undergoes an addition reaction with water, two products are formed.

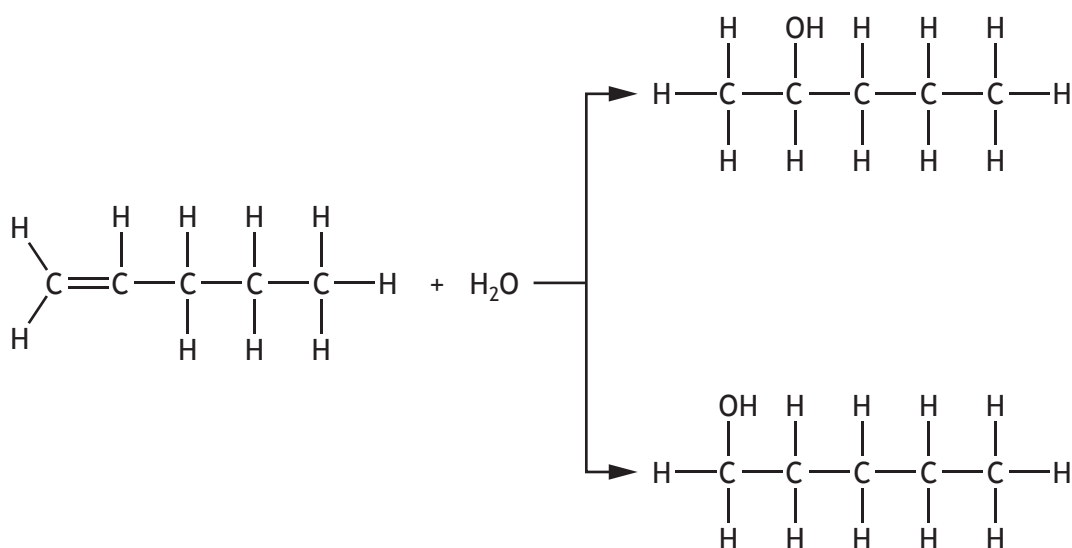

Which of the following alkenes will also produce two products when it undergoes an addition reaction with water?

- A Oct-2-ene
- B Hex-3-ene
- C But-2-ene
- D Ethene

16. In the Clemmensen reaction, ketones can be converted to alkanes as shown.

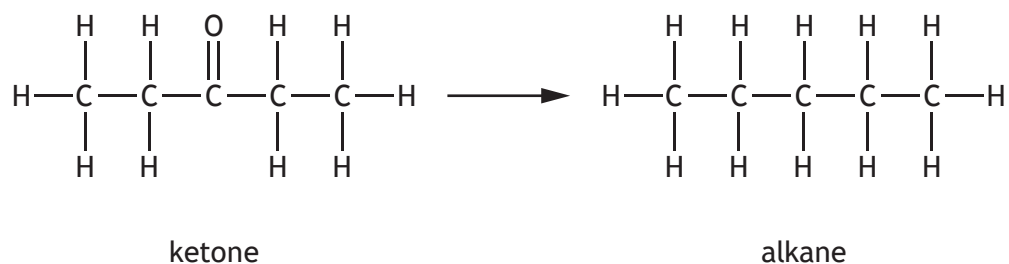

Identify the alkane produced if the following ketone was used in this reaction?

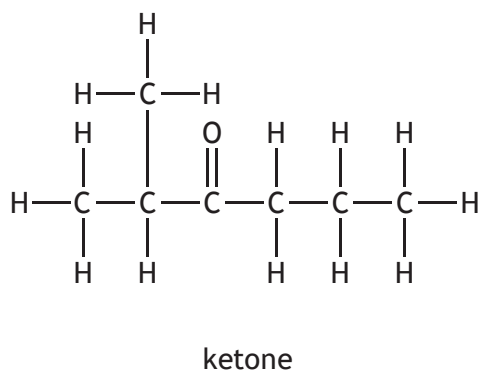

<p>A</p> $ \begin{array}{c} \text{H} \quad \text{H} \quad \text{H} \quad \text{H} \quad \text{H} \quad \text{H} \quad \text{H} \\ \quad \quad \quad \quad \quad \quad \\ \text{H}-\text{C}-\text{C}-\text{C}-\text{C}-\text{C}-\text{C}-\text{C}-\text{H} \\ \quad \quad \quad \quad \quad \quad \\ \text{H} \quad \text{H} \quad \text{H} \quad \text{H} \quad \text{H} \quad \text{H} \quad \text{H} \end{array} $	<p>B</p> $ \begin{array}{c} \text{H} \\ \\ \text{H}-\text{C}-\text{H} \\ \\ \text{H} \quad \text{H} \quad \text{H} \quad \text{H} \quad \text{H} \quad \text{H} \\ \quad \quad \quad \quad \quad \\ \text{H}-\text{C}-\text{C}-\text{C}-\text{C}-\text{C}-\text{C}-\text{H} \\ \quad \quad \quad \quad \quad \\ \text{H} \quad \text{H} \quad \text{H} \quad \text{H} \quad \text{H} \quad \text{H} \end{array} $
<p>C</p> $ \begin{array}{c} \text{H} \\ \\ \text{H}-\text{C}-\text{H} \\ \\ \text{H} \quad \text{H} \quad \text{H} \quad \text{H} \quad \text{H} \quad \text{H} \\ \quad \quad \quad \quad \quad \\ \text{H}-\text{C}-\text{C}-\text{C}-\text{C}-\text{C}-\text{C}-\text{H} \\ \quad \quad \quad \quad \quad \\ \text{H} \quad \text{H} \quad \text{H} \quad \text{H} \quad \text{H} \quad \text{H} \end{array} $	<p>D</p> $ \begin{array}{c} \text{H} \\ \\ \text{H}-\text{C}-\text{H} \\ \\ \text{H} \quad \text{H} \quad \text{H} \quad \text{H} \quad \text{H} \quad \text{H} \\ \quad \quad \quad \quad \quad \\ \text{H}-\text{C}-\text{C}-\text{C}-\text{C}-\text{C}-\text{C}-\text{H} \\ \quad \quad \quad \quad \quad \\ \text{H} \quad \text{H} \quad \text{H} \quad \text{H} \quad \text{H} \quad \text{H} \\ \\ \text{H}-\text{C}-\text{H} \\ \\ \text{H} \end{array} $

[Turn over

17. Which line in the table correctly describes the trends going from hexanoic acid to butanoic acid?

	Formula mass	Solubility in water
A	increasing	decreasing
B	decreasing	increasing
C	decreasing	decreasing
D	increasing	increasing

18. Four cells were made by joining silver to different metals.
The cells produced the following voltages 2.7 V, 1.1 V, 0.9 V and 0.5 V.

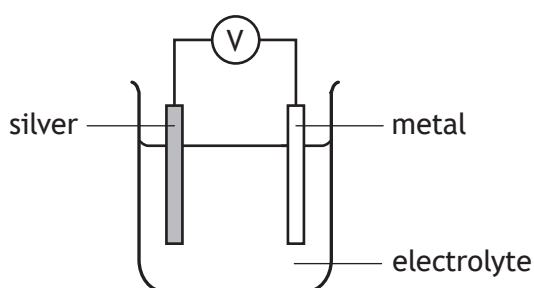

The metals used were copper, zinc, iron and magnesium.

Which voltage was produced in the cell containing silver and copper?

You may wish to use the data booklet to help you.

- A 2.7 V
- B 1.1 V
- C 0.9 V
- D 0.5 V

19. Information about the reactions of three different metals, X, Y and Z is given in the table.

Metal	Reaction with dilute acid	Reaction with water
X	reacts	no reaction
Y	no reaction	no reaction
Z	reacts	reacts

Which of the following shows the metals in order of **increasing** reactivity?

- A Y, Z, X
- B Z, X, Y
- C Y, X, Z
- D X, Y, Z

20. A co-polymer is formed when two different monomers polymerise.

Part of the structure of a co-polymer, showing three monomer units, is given below.

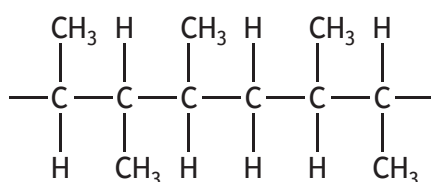

One of the monomers used is propene.

Identify the other monomer.

- A Pent-2-ene
- B Pent-1-ene
- C But-2-ene
- D But-1-ene

[Turn over

21. Nitrogen dioxide is a brown coloured gas that is soluble in water and more dense than air. Which of the following diagrams shows the most appropriate method for collecting and measuring the volume of nitrogen dioxide?

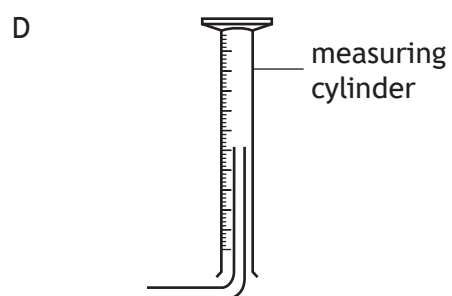
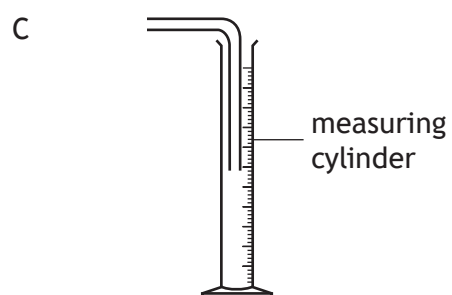
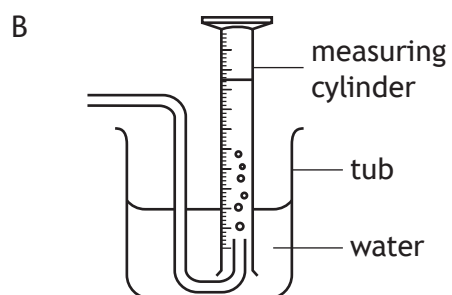
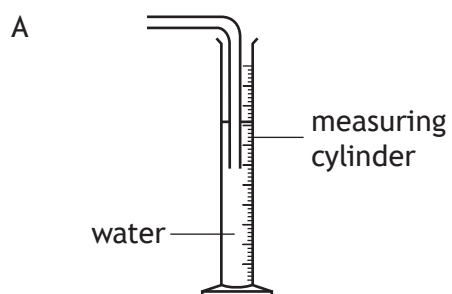

22. A solution of a metal chloride burns with a green flame.
Which of the following metal ions could be present in the metal chloride?
You may wish to use the data booklet to help you.

- A Ba^{2+}
- B Ca^{2+}
- C K^{+}
- D Na^{+}

23. Identify the gas that turns limewater cloudy.

- A Oxygen
- B Nitrogen
- C Hydrogen
- D Carbon dioxide

Questions 24 and 25 refer to the equation shown.

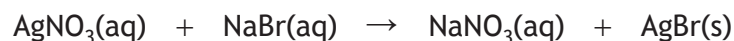

24. The reaction shown by the equation is an example of

- A addition
- B combustion
- C precipitation
- D neutralisation.

25. Which of the following ions are spectator ions in the reaction?

- A Ag^{+} and NO_3^{-}
- B Na^{+} and NO_3^{-}
- C Ag^{+} and Br^{-}
- D Na^{+} and Br^{-}

[END OF SECTION 1. NOW ATTEMPT THE QUESTIONS IN SECTION 2 OF
YOUR QUESTION AND ANSWER BOOKLET]

[BLANK PAGE]

DO NOT WRITE ON THIS PAGE