

FOR OFFICIAL USE



National  
Qualifications  
2015

Mark

**X716/75/01**

**Computing Science**

WEDNESDAY, 6 MAY

9:00 AM – 10:30 AM



\* X 7 1 6 7 5 0 1 \*

Fill in these boxes and read what is printed below.

Full name of centre

Town

Forename(s)

Surname

Number of seat

Date of birth

Day

Month

Year

Scottish candidate number

**Total marks – 90**

**SECTION 1 – 20 marks**

Attempt ALL questions.

**SECTION 2 – 70 marks**

Attempt ALL questions.

Show all working.

Write your answers clearly in the spaces provided in this booklet. Additional space for answers is provided at the end of this booklet. If you use this space you must clearly identify the question number you are attempting.

Use blue or black ink.

Before leaving the examination room you must give this booklet to the Invigilator; if you do not, you may lose all the marks for this paper.



\* X 7 1 6 7 5 0 1 0 1 \*

SECTION 1 - 20 MARKS  
Attempt ALL Questions

MARKS DO NOT WRITE IN THIS MARGIN

1. Convert the decimal number 164 into the equivalent 8-bit binary number.

1

2. A computer program is created to store data about the total number of pupils who pass an exam.

State the most suitable data type for the total.

1

---

---

3. The pseudocode shown below uses a simple condition.

IF age < 5 THEN SEND nursery TO DISPLAY

Create a complex condition that will display “school” if a person is between the ages of 5 and 18 inclusive.

2

---

---

---



4. A web browser keeps a history of websites visited. State **one** other feature of a web browser.

1

---



---

5. This pseudocode allows the user to guess the age of a teddy bear to win it in a competition.

```

Line 1    RECEIVE guess FROM (INTEGER) KEYBOARD
Line 2    WHILE guess < 1 OR guess > 80 DO
Line 3        SEND "invalid guess: please try again" TO DISPLAY
Line 4        RECEIVE guess FROM (INTEGER) KEYBOARD
Line 5    END WHILE
    
```

Complete the table below to show normal and exceptional test data for guess.

2

Type of Test Data	Test Data
normal	
exceptional	

[Turn over



\* X 7 1 6 7 5 0 1 0 3 \*

6. Kirsty is creating a website for a computer games company. Here is part of the page.



Give one reason why the design of these links is not good practice.

1

---



---

7. Explain the purpose of lines 5 to 8 in this pseudocode.

2

```

...
Line 4   SET password TO "h1gh@sch00l"
Line 5   REPEAT
Line 6       SEND "Please enter your password" TO DISPLAY
Line 7       RECEIVE user_guess FROM (INTEGER) KEYBOARD
Line 8   UNTIL password = user_guess
    
```

---



---



---



---



MARKS

DO NOT  
WRITE IN  
THIS  
MARGIN

8. Explain why file compression is used before transferring files to cloud storage.

1

---

---

---

---

9. Describe **two** methods of improving the readability of code.

2

Method 1 \_\_\_\_\_

---

---

Method 2 \_\_\_\_\_

---

---

10. State the **data type** of the variable “password” in the code below.

1

```
...  
Line 12 SEND “Please enter your password” TO DISPLAY  
Line 13 IF (password <> “h1gh@sch001”) THEN  
Line 14     SEND “error: please re-enter password” TO DISPLAY  
Line 15 END IF
```

---

[Turn over



\* X 7 1 6 7 5 0 1 0 5 \*

MARKS

DO NOT  
WRITE IN  
THIS  
MARGIN

11. Patryk is setting up a network for a school. Give **two** reasons why Patryk would choose a client/server network rather than a peer-to-peer network.

2

Reason 1 \_\_\_\_\_

\_\_\_\_\_

\_\_\_\_\_

Reason 2 \_\_\_\_\_

\_\_\_\_\_

\_\_\_\_\_

12. Katie is in her back garden using her smartphone to access her neighbour's wireless network. State the law Katie is breaking.

1

\_\_\_\_\_

13. Describe how **keylogging** can be an online security risk.

1

\_\_\_\_\_

\_\_\_\_\_

\_\_\_\_\_

\_\_\_\_\_

\_\_\_\_\_

\_\_\_\_\_

14. A company has both a wired and wireless network. The wireless network allows portability of workstations. Describe **one** advantage for the company of the wired network over the wireless network.

1

\_\_\_\_\_

\_\_\_\_\_

\_\_\_\_\_

\_\_\_\_\_



\* X 7 1 6 7 5 0 1 0 6 \*

15. All of the links in this information system have been tested.

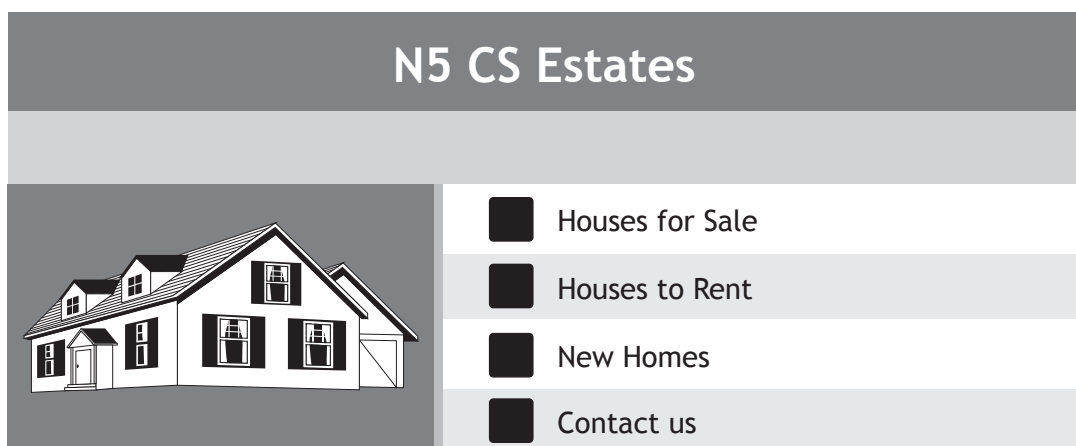

N5 CS Estates

- Houses for Sale
- Houses to Rent
- New Homes
- Contact us

State one other type of testing that is used in this information system.

1

---

---

---

[Turn over



SECTION 2 - 70 MARKS

Attempt ALL Questions

MARKS  
DO NOT  
WRITE IN  
THIS  
MARGIN

16. A retailer wants to set up a website to sell products online.  
A template is selected which helps create the website by providing a ready-made structure as shown below.

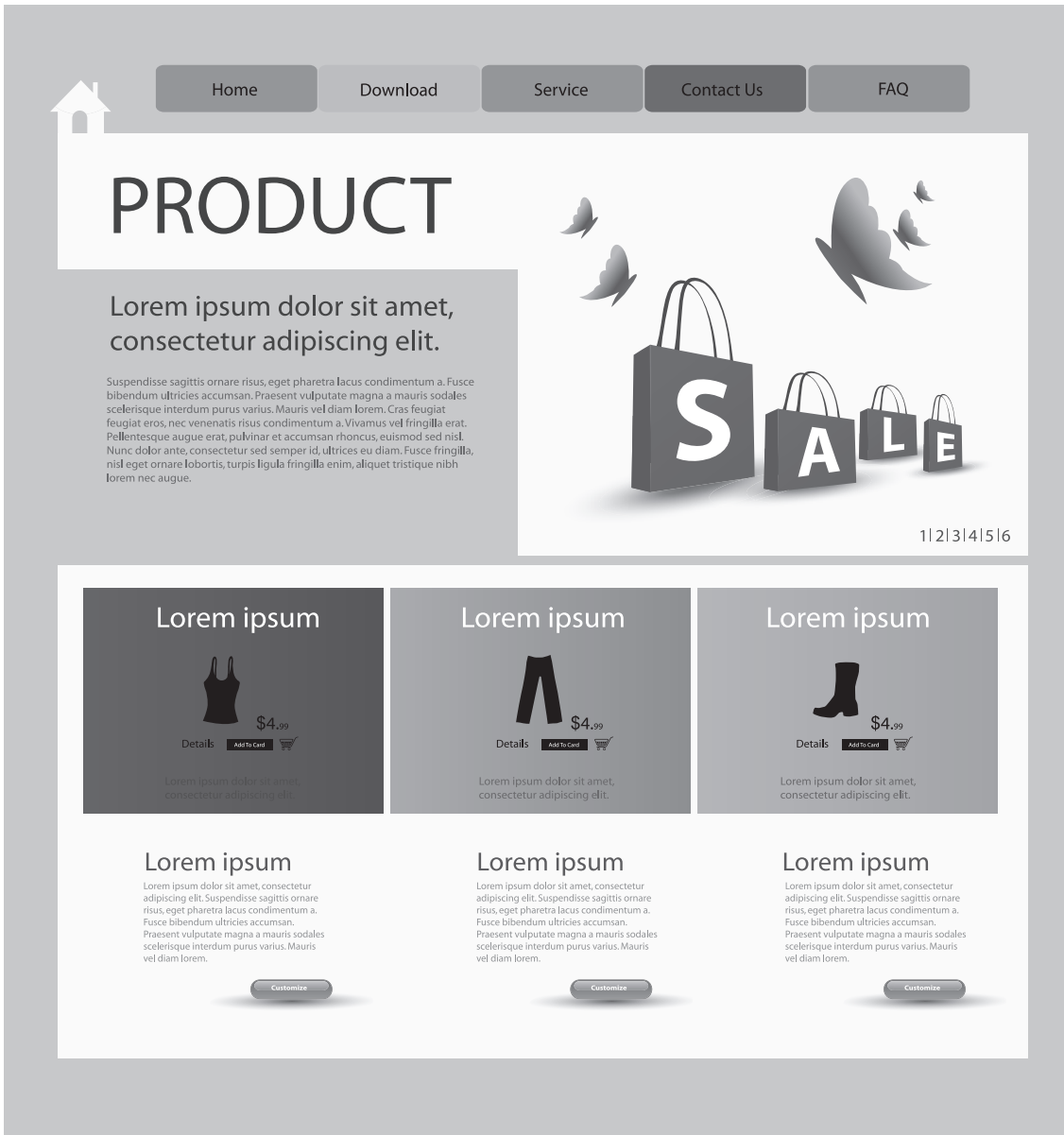

- (a) The template shown above provides consistency of font - colour, style and size of text.

Identify other features to aid good user interface design.

2

---

---

---

---



Question 16 (continued)

- (b) Once the website is created using the template, it is tested using a variety of browsers.

Explain why the webpages appear the same in each web browser.

1

---



---



---

- (c) Each web page requires an image of one of the products. A suitable photograph is taken with a digital camera and uploaded to a computer for editing.

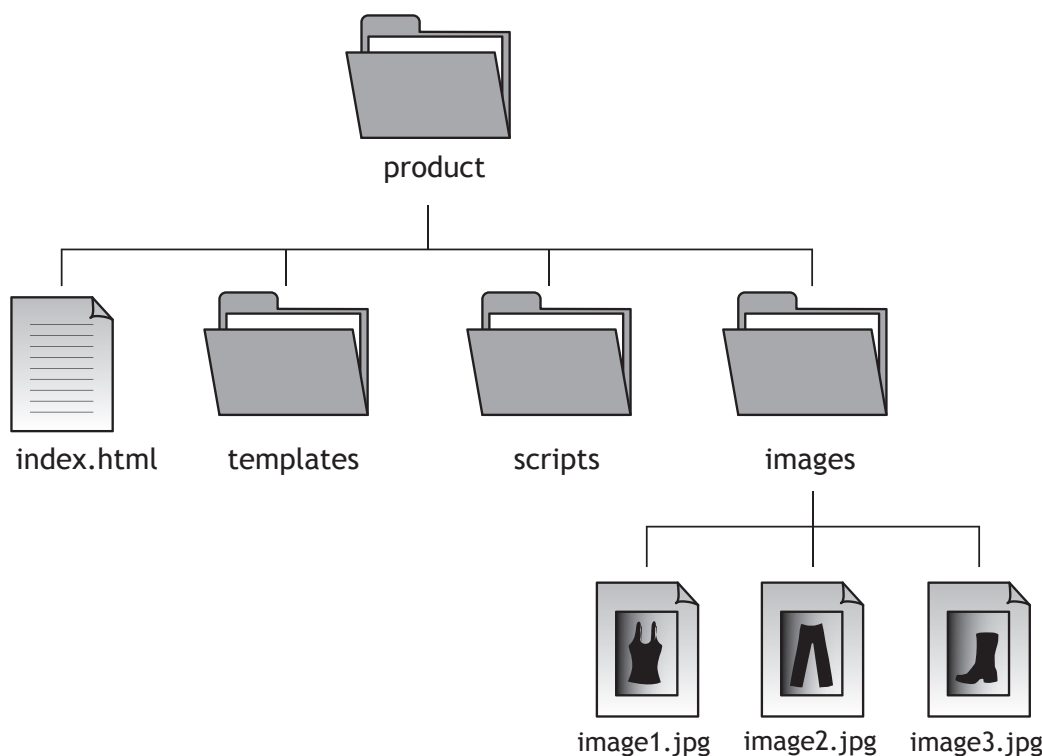

- (i) A photograph for the homepage is stored in a folder called **images** as shown above.

The photograph is stored as **image1.jpg**. Name **one** other standard file format for graphics.

1

---

- (ii) State the type of addressing that should be used to include the file **image1.jpg** on the **index.html** page.

1

---



Question 16 (c) (continued)

- (iii) The photograph, before editing, is 4 inch by 6 inch with a resolution of 600 dpi and 24-bit colour depth. Calculate the file size of the photograph.

State your answer using appropriate units. Show all your working.

3

- (d) A website contains a search engine.

Explain how a search engine is used to produce a list of results.

2

---

---

---

---

---

---

---



17. Pseudocode for a short program is written to calculate VAT on products. Part of the pseudocode is shown below.

```

...
Line 7   SET vatRate TO 0.2
Line 8   RECEIVE productCost FROM (REAL) KEYBOARD
Line 9   SET productVat TO productCost * vatRate
    
```

(a) Explain how the value in the variable productCost will be stored in the computer. 2

---



---



---



---

(b) The program is tested but stops running after a few lines. An error is highlighted.

(i) Name the type of translator being used. 1

---

(ii) State **one** disadvantage of using this type of translator. 1

---



---

(c) When all errors are removed, the completed program is translated. A section of the translated code is shown below.

```

| 1 0 1 1 0 0 0 1 |
| 0 0 1 0 1 1 1 0 |
| 1 1 1 1 0 1 0 1 |
| 0 1 1 0 1 1 1 0 |
    
```

State the type of programming language the code has been translated into. 1

---



Question 17 (continued)

(d) A diagram of a computer system is shown below.

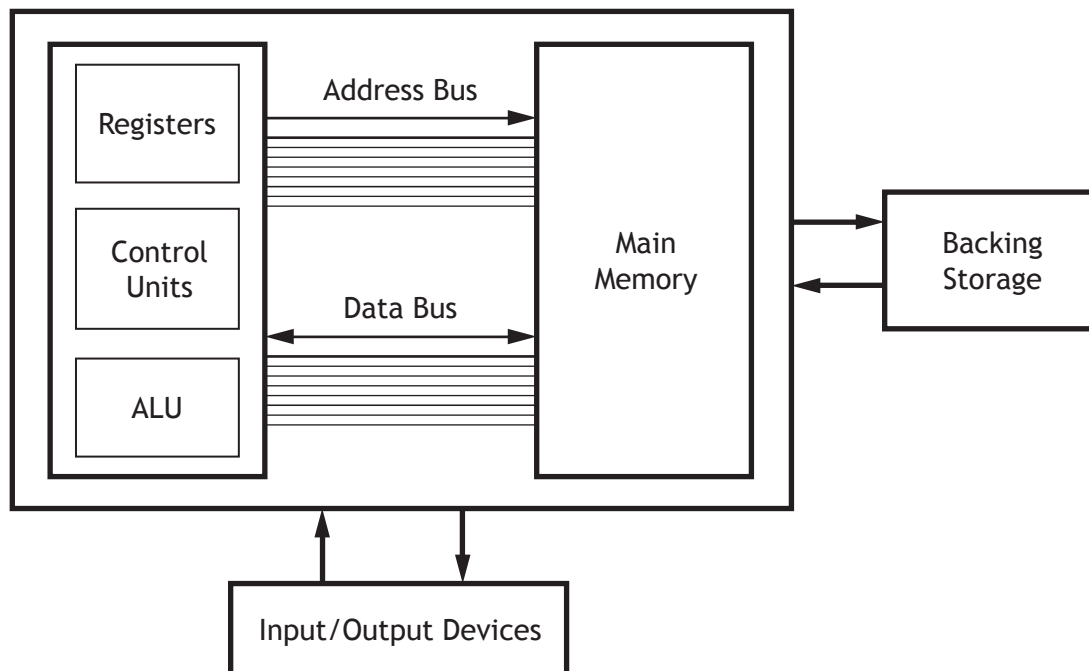

The following part of the program is executed.

```

...
Line 9   SET productVat TO productCost * vatRate
    
```

Name the part of the computer system that will carry out each of the following tasks during the execution of this line of code.

- (i) Carries the location of productCost in main memory. 1  
\_\_\_\_\_
- (ii) Transfers the value of productCost from main memory to the processor. 1  
\_\_\_\_\_
- (iii) Performs the VAT calculation. 1  
\_\_\_\_\_



Question 17 (continued)

MARKS

DO NOT  
WRITE IN  
THIS  
MARGIN

- (e) The program is backed-up onto an external hard drive which is connected to the computer using an interface.

Describe **two** purposes of an interface.

2

Purpose 1 \_\_\_\_\_

\_\_\_\_\_

Purpose 2 \_\_\_\_\_

\_\_\_\_\_

[Turn over



\* X 7 1 6 7 5 0 1 1 3 \*

18. Here is the School Learner section of the Scottish Qualifications Authority (SQA) website.

MARKS

DO NOT  
WRITE IN  
THIS  
MARGIN

The screenshot shows a web browser window with the URL <http://www.sqa.org.uk/sqa/41288.html>. The page features the SQA logo and navigation links like 'Contact Us', 'A-Z', and a search bar. The breadcrumb trail reads 'SQA Home > I am a... > Learner > School learner'. The main heading is 'Information for School Learners: Past Papers, Exam timetables'. Below this, there is a paragraph: 'Here you can find information and resources to help you, if you are studying for National Qualification Courses and exams.' followed by another paragraph: 'If you are sitting exams, be sure to make use of all the resources we have on offer — Past Papers, Study Guides, Apps for your phone and much more.' To the right of the text is a video player with a 'Play' button and a 'Read Transcript' link. The left sidebar contains 'In this section' with links to 'Exam Tools', 'Next Step', 'Your Coursework', and 'Your Exams 2014'. The right sidebar has 'Contact Information' (Learner Enquiries, 0345 279 1000) and 'Related Information' (MySQA 2014 leaflet for candidates (431 KB), MySQA 2014 leaflet for centres (437 KB)).

(a) Describe one **purpose** of this section of the website.

1

---

---

---

---

(b) State the domain name of this webpage URL.

1

---

(c) This web page design includes several features to aid accessibility.

(i) Identify **one** of these features.

1

---

---

(ii) Explain how this feature aids accessibility.

1

---

---

---

---

---



Question 18 (continued)

- (d) The HTML code used to include the SQA logo uses the *img src* tag shown below.

```
<img src= “../images/sqa-logo.gif”>
```

Name the standard file format used to store the image.

1

---

---

- (e) The web page includes the following navigation feature (breadcrumb).



Explain how this feature aids navigation.

1

---

---

---

---

---



[Turn over



Question 18 (continued)

- (f) Sally uses the Exam Tools section to search for her own National 5 courses to build her own timetable and print the result.

Subject	Qualification	Date	Time	?
Italian	National 5	Thursday 30 April 2015	09:00–10:30	⊖
Italian	National 5	Thursday 30 April 2015	10:50–11:15	⊖
Graphic Communication	National 5	Thursday 30 April 2015	13:00–14:30	⊖
Computing Science	National 5	Wednesday 6 May 2015	09:00–10:30	⊖
Music	National 5	Friday 8 May 2015	13:00–13:45	⊖
English	National 5	Thursday 14 May 2015	09:00–10:00	⊖
English	National 5	Thursday 14 May 2015	10:20–11:50	⊖
Art and Design	National 5	Friday 29 May 2015	13:30–14:40	⊖

 [Export to iCal](#)
 [Print](#)
 [Email my Timetable](#)

Subject

Qualification

Circle **one** example on the webpage above that might make use of Javascript. 1

- (g) Describe how the personal National 5 timetable results have been sorted. 2

---



---



---



---



Question 18 (continued)

MARKS

DO NOT  
WRITE IN  
THIS  
MARGIN

- (h) Sally downloads a past paper from another area of the website.

Describe **one** concern that Sally might have when she downloads a past paper.

1

---

---

---

---

[Turn over



\* X 7 1 6 7 5 0 1 1 7 \*

19. A program is written to calculate the cost of feeding chickens for one month. Chickens eat 5 Kilograms of grain each month. An incomplete design for the program is shown below.

Line 1	SEND “Enter the number of chickens and the cost of grain” TO DISPLAY
Line 2	RECEIVE numberOfChickens FROM (_____) KEYBOARD
Line 3	RECEIVE pricePerKilo FROM (_____) KEYBOARD
Line 4	SEND “Is the grain full price?” TO DISPLAY
Line 5	RECEIVE fullPrice FROM (_____) KEYBOARD
Line 6	IF fullPrice = True THEN
Line 7	SET totalPrice TO numberOfChickens *5*pricePerKilo
Line 8	END IF
Line 9	IF fullPrice = False THEN
Line 10	SET totalPrice TO numberOfChickens *5*(pricePerKilo*0.8)
Line 11	END IF
Line 12	SEND [“The total cost of grain required for” & numberOfChickens & “chickens is £” & totalPrice] TO DISPLAY

- (a) The above design should show the type of data being entered by keyboard in Lines 2, 3 and 5. State the most appropriate data types for the following variables.

3

numberOfChickens \_\_\_\_\_

pricePerKilo \_\_\_\_\_

fullPrice \_\_\_\_\_



\* X 7 1 6 7 5 0 1 1 8 \*

Question 19 (continued)

MARKS

DO NOT  
WRITE IN  
THIS  
MARGIN

- (b) (i) State the lines of pseudocode that contain conditional statements. 2

---

---

- (ii) State the part of the processor that compares the values in a conditional statement. 1

---

- (c) The program is later improved to store the totalPrice for each month of a year.

- (i) State the data structure that would be required to store the list of totalPrice values. 2

---

---

- (ii) State the **type** of loop required to repeat the code in lines 1 to 12 for each month of the year. Explain why this type of loop would be used. 2

Type of Loop \_\_\_\_\_

Explanation \_\_\_\_\_

---

---

[Turn over



\* X 7 1 6 7 5 0 1 1 9 \*

20. A supermarket has a flat file database storing information about the 20,000 products it stocks. Part of the database is shown below.

Dept ID	Dept Name	Department Manager	Product Code	Product Type	Product Name
4	Toiletries	H Green	100356	Toothpaste	Dentasparkle
10	Dry Goods	A Ahmed	204672	Cereal	Oatycrunch
6	Cleaning Products	F McMaster	318410	Shoe Polish	Shine
10	Dry Goods	A Ahmed	396039	Packet Soup	Mug-o-Soup
10	Dry Goods	A Ahmed	401284	Biscuits	Choco Snaps
4	Toiletries	H Green	672936	Shower Gel	Clean & Fresh
6	Cleaning Products	F McMaster	324221	Wipes	GermGo

(a) The design structure of the database looks like this.

Field Name	Field Type	Field Size	Validation
Dept ID	Number	2	>0 and <11
Dept Name	Text	20	
Department Manager	Text	20	
Product Code	Text	6	Required
Product Type	Text	20	
Product Name	Text	20	

Name **two** types of *validation* that could be applied to the field **Product Code**.

2

Validation 1 \_\_\_\_\_

Validation 2 \_\_\_\_\_

(b) The supermarket decides to change the name of the “Cleaning Products” department to “Household Products”. Describe a potential problem when changing this data in a *flat file* database design.

1

\_\_\_\_\_

\_\_\_\_\_

\_\_\_\_\_

\_\_\_\_\_



Question 20 (continued)

(c) A decision is made to modify the design of the database to *linked tables* with two tables: DEPARTMENT and PRODUCT. Each table will have a *primary key*.

(i) State the purpose of a primary key.

1

\_\_\_\_\_

\_\_\_\_\_

\_\_\_\_\_

(ii) Identify a suitable primary key for each table.

2



DEPARTMENT \_\_\_\_\_

PRODUCT \_\_\_\_\_

(d) Three new fields

Product In Stock, Product Picture and Product Price

are to be inserted into the PRODUCT table as shown below.

Product Code	Product Type	Product Name	Product in Stock	Product Picture	Product Price
100356	Toothpaste	Dentasparkle	True		1.99
204672	Cereal	Oatycrunch	False		2.45

Name a suitable *field type* for the following new fields.

2

Product In Stock \_\_\_\_\_

Product Picture \_\_\_\_\_

[Turn over



Question 20 (continued)

MARKS

DO NOT  
WRITE IN  
THIS  
MARGIN

- (e) The supermarket decides to replace its current computers.

Explain two ways the company should dispose of the “old” computer systems.

2

---

---

---

---

---

---

---

---

---

---



\* X 7 1 6 7 5 0 1 2 2 \*

MARKS

DO NOT  
WRITE IN  
THIS  
MARGIN

[Turn over for Question 21 on *Page twenty-four*

DO NOT WRITE ON THIS PAGE



\* X 7 1 6 7 5 0 1 2 3 \*

21. A program is required to calculate the quantity of bricks required to build a wall. The program will ask the user to enter the dimensions of the wall and a single brick. 1 cm will be added onto the dimensions of the brick to allow for mortar between the bricks. Area of a rectangle is calculated by multiplying the length by height.

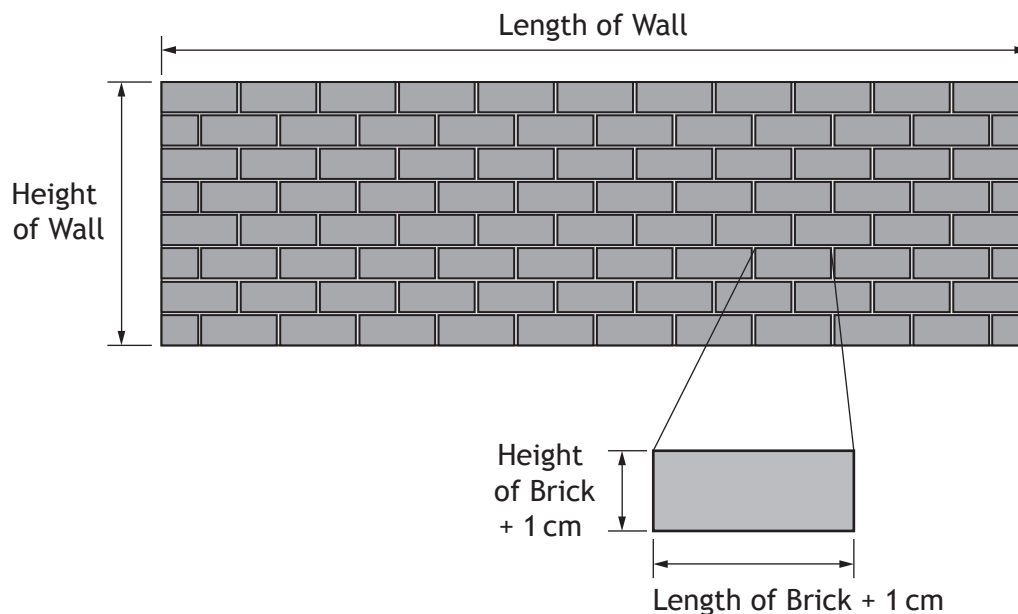

A design for the program is shown below.

```

Line 1    RECEIVE lengthOfWall FROM (REAL) KEYBOARD
Line 2    RECEIVE heightOfWall FROM (REAL) KEYBOARD
Line 3    RECEIVE lengthOfBrick FROM (REAL) KEYBOARD
Line 4    RECEIVE heightOfBrick FROM (REAL) KEYBOARD
Line 5    SET lengthOfBrick TO lengthOfBrick + 1
Line 6    SET heightOfBrick TO heightOfBrick + 1
Line 7    <calculate the quantity of bricks needed>
Line 8    SEND ["The number of bricks needed is –" numberOfBricks] TO
          DISPLAY
  
```



## Question 21 (continued)

- (a) A brick length must be greater than 15 and less than 50.

Using pseudocode or a programming language of your choice, show how input validation could be used to ensure a valid brick length is entered by the user.

3

Pseudocode	<input type="checkbox"/>	OR Programming Language	<input type="checkbox"/>

- (b) Using the information obtained in Lines 1 to 6.

Use pseudocode or a programming language of your choice to show how Line 7 would be implemented.

4

Pseudocode	<input type="checkbox"/>	OR Programming Language	<input type="checkbox"/>



\* X 7 1 6 7 5 0 1 2 5 \*

Question 21 (continued)

- (c) The program is tested and gives the following output.

The number of bricks needed is: 345.32

The number of bricks needing to be ordered is 346.

Describe how a pre-defined function could be used to ensure that the correct number of bricks is ordered.

2

---

---

---

---

---

- (d) Mortar is required to hold the bricks in place. The following calculation will be used to calculate the amount of mortar required.

Mortar = (2 \* sand) + cement + water

State the number of variables required.

1

---



22. Maggie has just started her own photography business taking pictures at weddings and party events. She uses her digital camera with a different 64 Gigabyte memory card for each event.

- (a) The memory card in the camera is an example of solid state storage. Explain why this is more suitable for a digital camera than magnetic storage.

2

---

---

---

- (b) If a photograph file is 25 Megabytes in size, calculate how many photos Maggie can take at each event before her memory card is full.

Show your working.

2

Maggie transfers the photos to her tablet before the end of each event so that guests can browse the images and then place orders to buy copies.

- (c) Describe **two** advantages of using a tablet rather than a laptop computer for this task.

2

Advantage 1 \_\_\_\_\_

---

Advantage 2 \_\_\_\_\_

---



Question 22 (continued)

Maggie discovers that using one tablet restricts the number of guests who can view the images during the event and as a result, she does not make many sales.

- (d) Maggie decides to use an app called SnapsGalore with cloud storage to organise and manage her photos.



Unlimited cloud storage

*SnapsGalore*

- No more storage capacity problems
- Unlimited secure storage
- Automatic backup
- Multiple login options
- Cross platform OS compatibility
- Searchable database automatically created when you upload

- (i) Describe how cloud storage can be used to provide wider access to the photos. 1

---



---



---



---

- (ii) Identify the feature of the app that allows guests to access the photos even though they have different types of devices. 1

---



---



Question 22 (continued)

- (e) Maggie uses the free wireless (WiFi) connection in the venue to transfer the images from the tablet to the SnapsGalore server.

Describe **two** concerns she may have about using the WiFi connection.

2

Concern 1 \_\_\_\_\_

\_\_\_\_\_

\_\_\_\_\_

Concern 2 \_\_\_\_\_

\_\_\_\_\_

\_\_\_\_\_

[END OF QUESTION PAPER]



\* X 7 1 6 7 5 0 1 2 9 \*

ADDITIONAL SPACE FOR ANSWERS

MARKS

DO NOT  
WRITE IN  
THIS  
MARGIN



\* X 7 1 6 7 5 0 1 3 0 \*

ADDITIONAL SPACE FOR ANSWERS

MARKS

DO NOT  
WRITE IN  
THIS  
MARGIN



\* X 7 1 6 7 5 0 1 3 1 \*

## ACKNOWLEDGEMENTS

Question 16 – Hubis/shutterstock.com

Question 20(d) – Rashevskiy Viacheslav/shutterstock.com  
Matthew Cole/shutterstock.com

Question 22(d) – musicman/shutterstock.com



\* X 7 1 6 7 5 0 1 3 2 \*