

FOR OFFICIAL USE



National
Qualifications
2021 ASSESSMENT RESOURCE

Mark

X819/75/01

Design and Manufacture

Duration — 1 hour 45 minutes



* X 8 1 9 7 5 0 1 *

Fill in these boxes and read what is printed below.

Full name of centre

Town

Forename(s)

Surname

Number of seat

Date of birth

Day

Month

Year

Scottish candidate number

Total marks — 80

SECTION 1 — 60 marks

Attempt ALL questions.

SECTION 2 — 20 marks

Attempt ALL questions.

Write your answers clearly in the spaces provided in this booklet. Additional space for answers is provided at the end of this booklet. If you use this space you must clearly identify the question number you are attempting.

Show all working and units where appropriate.

Use **blue** or **black** ink.

Before leaving the examination room you must give this booklet to the Invigilator; if you do not, you may lose all the marks for this paper.



* X 8 1 9 7 5 0 1 0 1 *

SECTION 1 — 60 marks
Attempt ALL questions

1. A design proposal for a photo and note display is shown below.

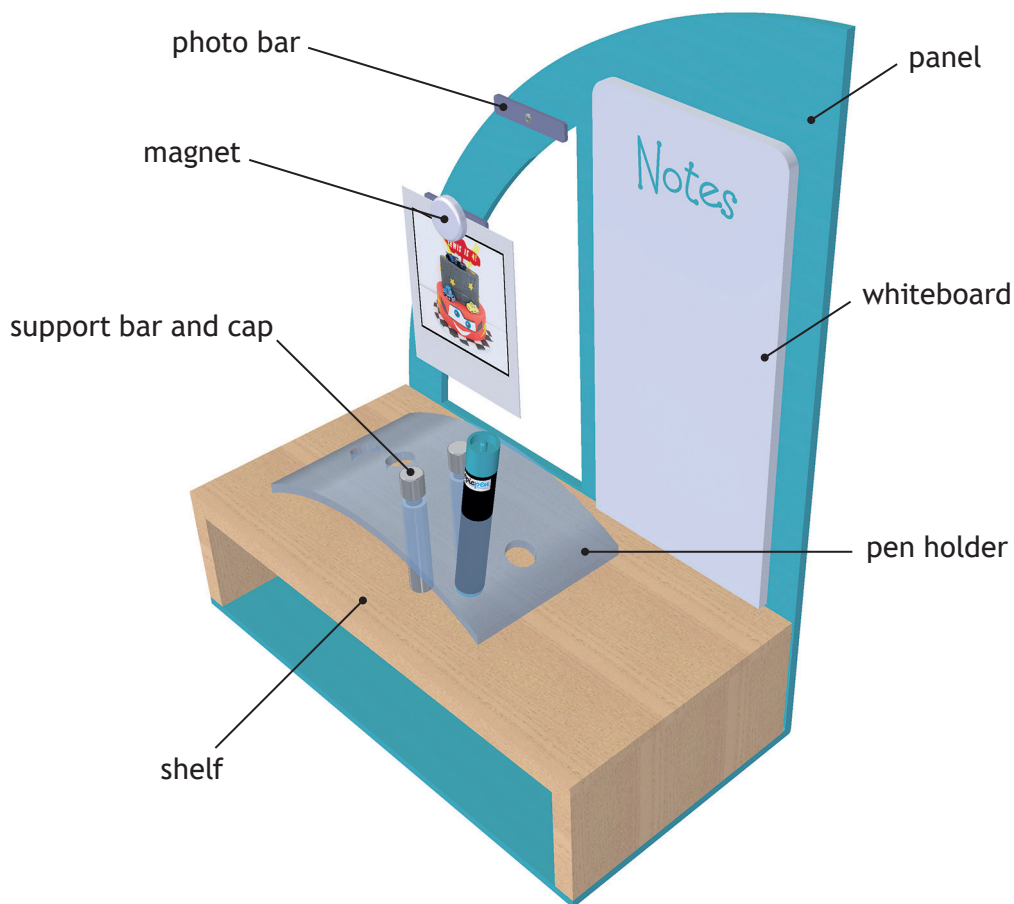

(a) The photo and note display was made from different materials.

(i) Name a suitable silver, non-ferrous metal for the support bars. 1

Magnets were used to hold photos onto the metal photo bars.

(ii) Name a suitable metal for the photo bars. 1



1. (continued)

- (b) The photo bars were dip coated.

Describe how the photo bars would be dip coated, with reference to workshop tools and equipment.

You may use sketches to illustrate your answer in the box below.

2

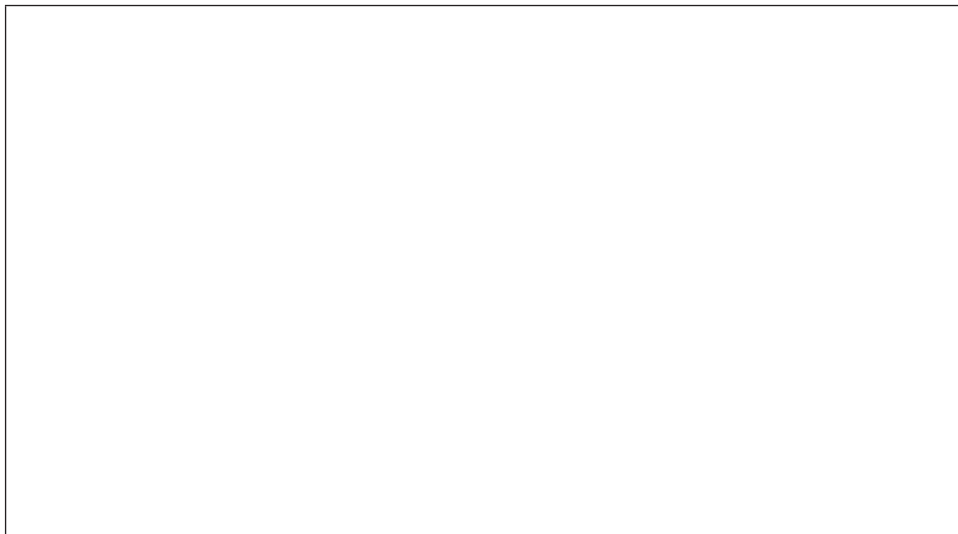

[Turn over



* X 8 1 9 7 5 0 1 0 3 *

1. (continued)

(c) The support bars and their caps were manufactured on a centre lathe.

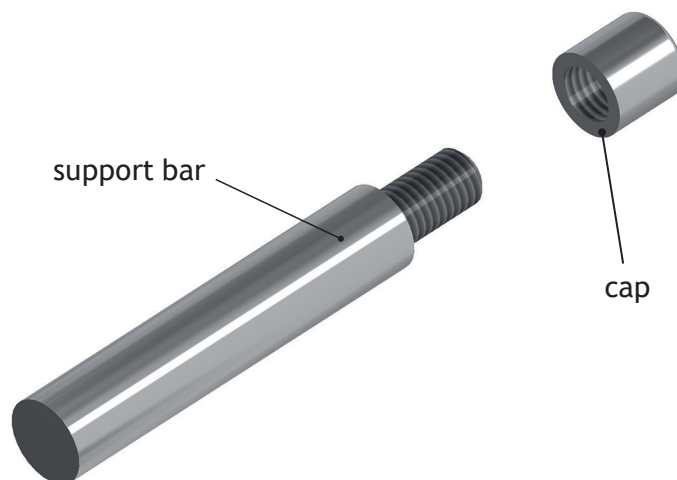

(i) Outline **two** safety checks that must be carried out on the centre lathe **before** the parts are manufactured.

2

The end of the support bar was machined on the centre lathe **before** threading as shown below.



(ii) Name **two** of the processes carried out on the centre lathe to produce the machined features.

2



1. (c) (continued)

The cap was manufactured from a blank as shown below.

blank

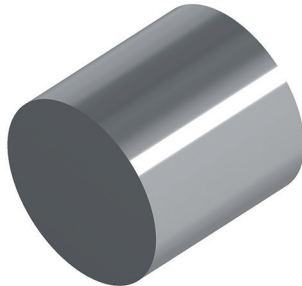

finished cap

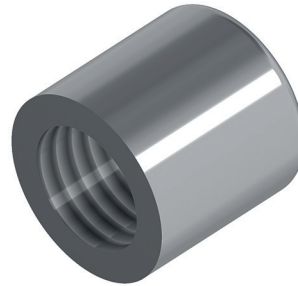

(iii) Describe how the finished cap would be manufactured from the blank, with reference to workshop tools and equipment.

You may use sketches to illustrate your answer in the box below.

3



1. (continued)

(d) The pen holder shown below was made from acrylic.

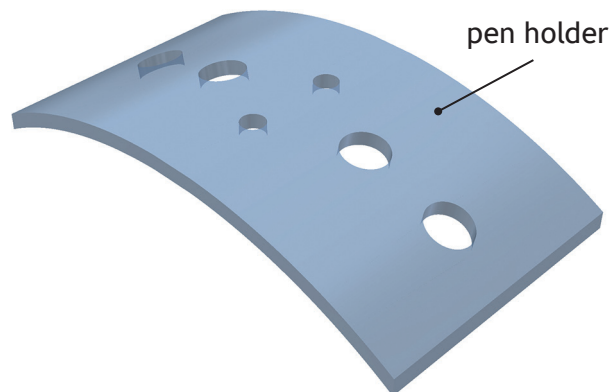

- (i) State **two** reasons why acrylic is a suitable material for the pen holder.

2

- (ii) Outline **one** method of preventing the acrylic from cracking during drilling.

1



* X 8 1 9 7 5 0 1 0 6 *

1. (d) (continued)

- (iii) Describe how the curve on the acrylic pen holder could be formed accurately, with reference to workshop tools and equipment.

You may use sketches to illustrate your answer in the box below.

3

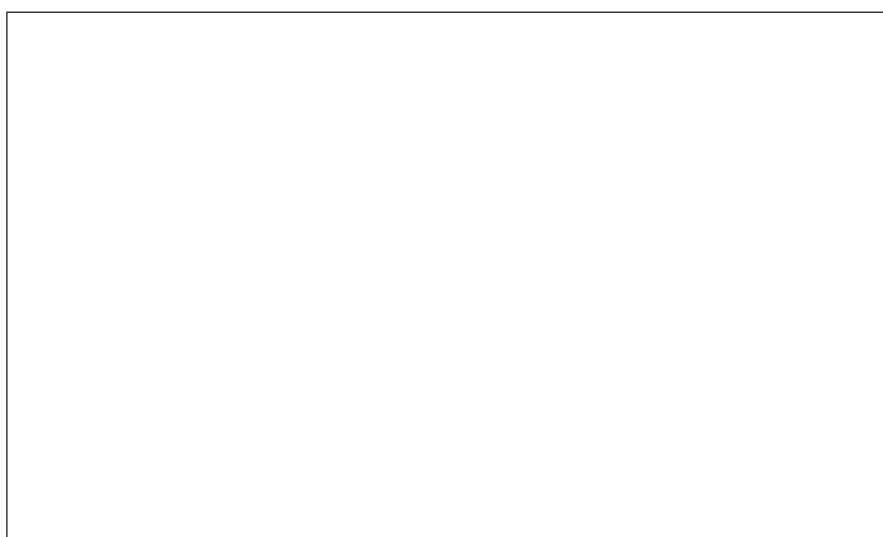

[Turn over



* X 8 1 9 7 5 0 1 0 7 *

1. (continued)

(e) The wooden shelf was manufactured using a lap joint.

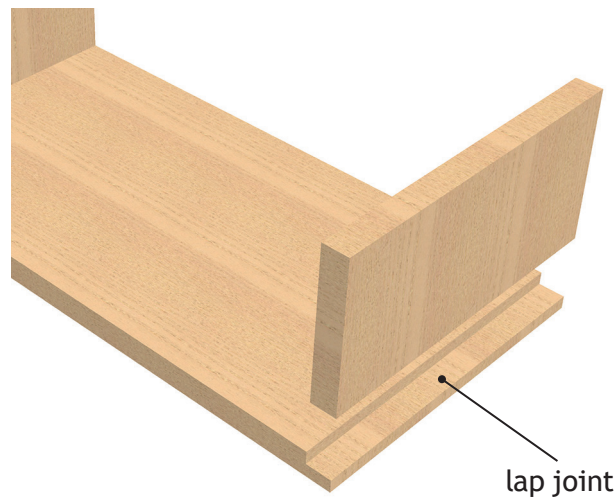

(i) Describe how the lap joint could be marked **and** cut out accurately. You must refer to workshop tools in your answer.

You may use sketches to illustrate your answer in the box on page 09.

4



1. (e) (i) (continued)

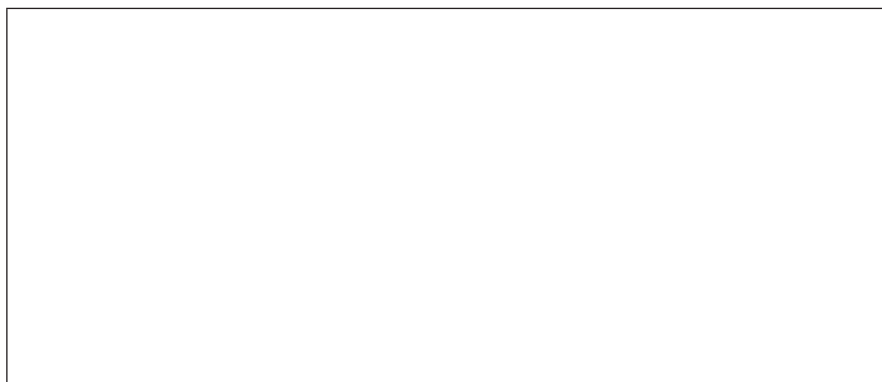

(ii) Name a suitable light-coloured softwood for the wooden shelf. 1

(iii) Outline **two** reasons why varnish is a suitable finish for the shelf. 2

[Turn over



* X 8 1 9 7 5 0 1 0 9 *

1. (continued)

MARKS
DO NOT
WRITE IN
THIS
MARGIN

(f) The panel was manufactured from acrylic and bent as shown below.

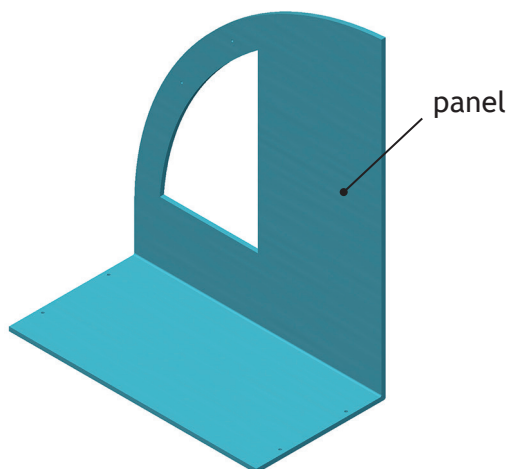

(i) State why a strip heater was used instead of an oven to heat the acrylic panel before bending.

1

Pilot holes were created in the wooden shelf.

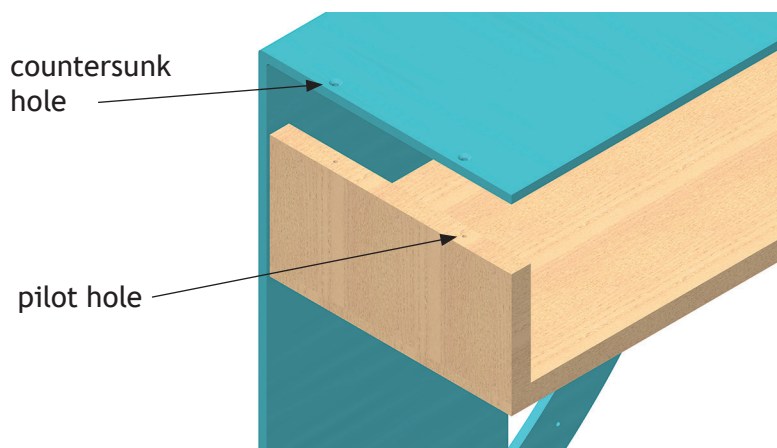

(ii) Explain why pilot holes were used.

2



1. (f) (continued)

- (iii) State why the holes on the underside of the panel were countersunk.

1

The whiteboard was joined to the panel using an adhesive.

- (iv) Explain why an adhesive was used rather than screws.

2

[Turn over



* X 8 1 9 7 5 0 1 1 1 *

2. An office chair was researched by a designer.



- (a) A user trip is a research technique that designers can use to gather information.
- (i) Outline **three** pieces of information about the office chair that could be gained from a user trip.

3

- (ii) Name an alternative research technique.

1



2. (continued)

(b) Morphological analysis is an idea generation technique used by designers.

(i) Describe the key stages of morphological analysis.

You may use sketches to illustrate your answer in the box below.

3

(ii) Name an alternative idea generation technique.

1

[Turn over



* X 8 1 9 7 5 0 1 1 3 *

3. Different graphic techniques can be used throughout the design process.

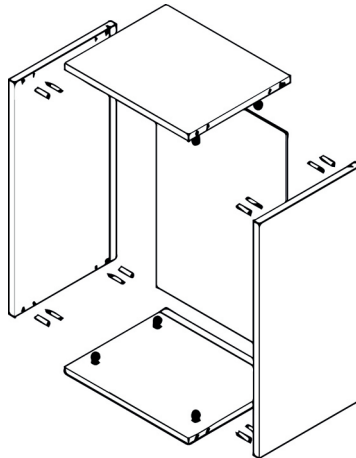

exploded view

(a) Outline **two** pieces of information that can be gained from an exploded view.

2

(b) Outline **two** reasons for using sketching when generating ideas.

2



5. A range of factors have been considered in the design of the cooker shown below.



You must give different examples in (a) and (b).

- (a) Describe how safety has influenced the design of the cooker.

2



* X 8 1 9 7 5 0 1 1 6 *

MARKS

DO NOT
WRITE IN
THIS
MARGIN

7. The design of products can be influenced by branding and the target market.

(a) Outline **two** benefits of selling a product under a brand name.

2

(b) Describe what is meant by market pull.

1

[Turn over



* X 8 1 9 7 5 0 1 1 9 *

SECTION 2 — 20 marks

Attempt ALL questions

8. The cordless electric drill and drill bit shown below have been produced using a range of materials and processes.

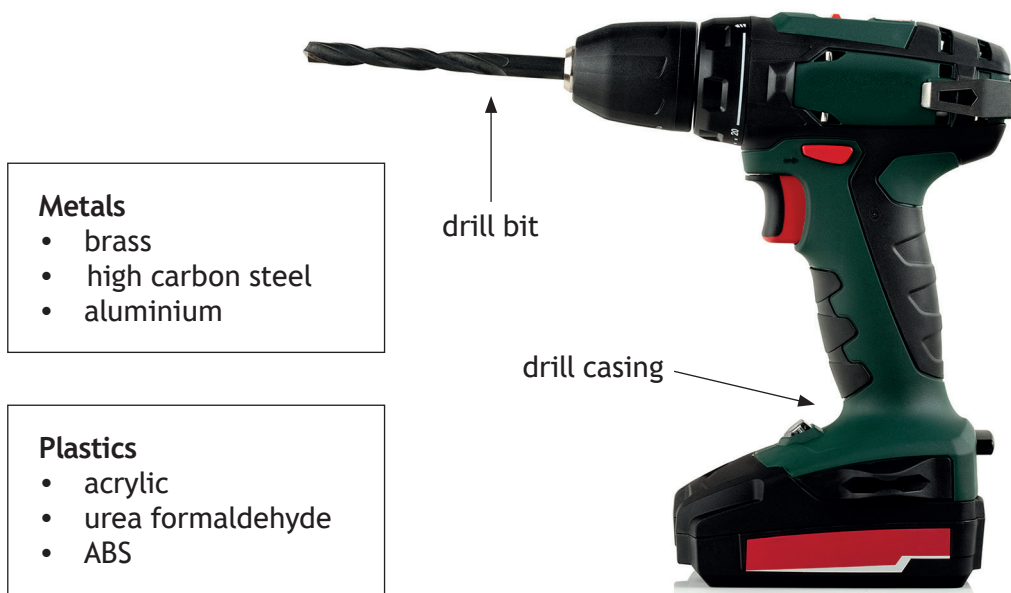

- (a) Select appropriate materials for the drill bit and drill casing from the lists provided and state why they would be suitable.

A different material and property must be given for each item.

- (i) Drill bit. 2

Metal _____

Suitable because _____

- (ii) Drill casing. 2

Plastic _____

Suitable because _____



8. (continued)

(b) The drill casing was mass produced using injection moulding.

State **two** features that would identify that the casing has been injection moulded.

2

(c) To provide protection during transport, removable plastic packaging was used to support the drill bits within their case.

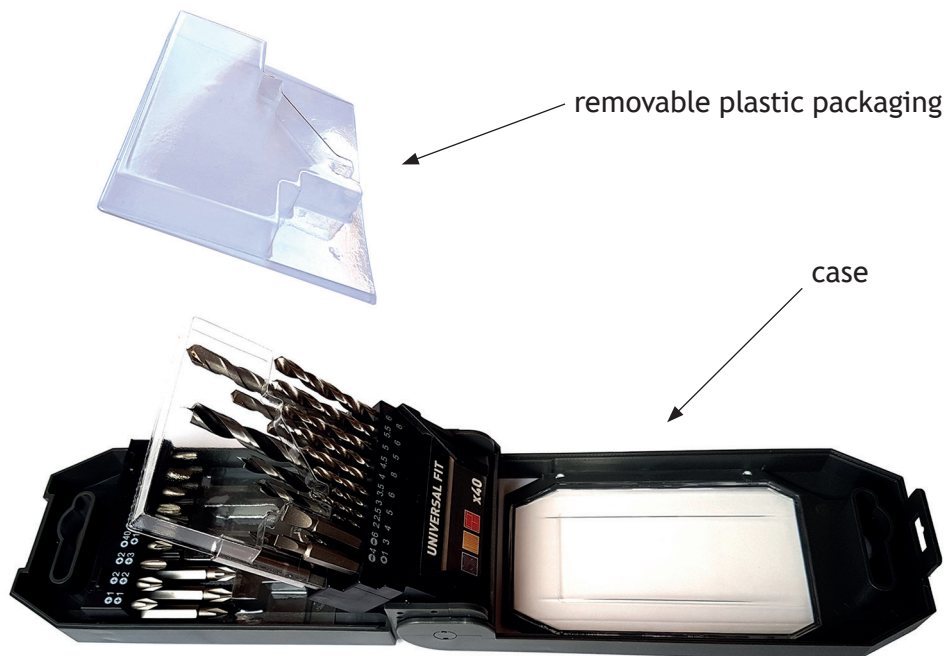

The packaging was vacuum formed around a pattern that contained features such as tapered sides and rounded corners.

State a different manufacturing reason for each feature.

(i) Tapered sides.

1

(ii) Rounded corners.

1



* X 8 1 9 7 5 0 1 2 1 *

11. Modern design and manufacturing technologies have had an impact on society and the environment.

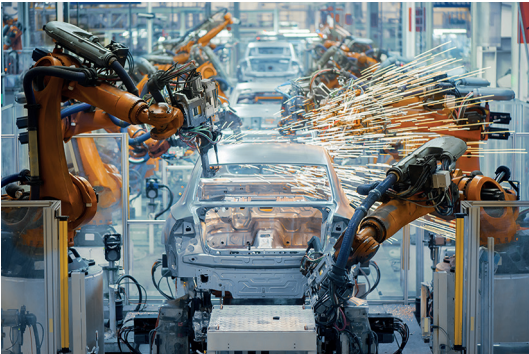

You must give different examples in (a), (b) and (c).

Describe the impact of these technologies on

(a) the supply of products.

2

(b) the workforce.

2



MARKS

DO NOT
WRITE IN
THIS
MARGIN

11. (continued)

(c) pollution.

2

[END OF QUESTION PAPER]



* X 8 1 9 7 5 0 1 2 5 *

MARKS

DO NOT
WRITE IN
THIS
MARGIN

ADDITIONAL SPACE FOR ANSWERS



* X 8 1 9 7 5 0 1 2 6 *

MARKS

DO NOT
WRITE IN
THIS
MARGIN

ADDITIONAL SPACE FOR ANSWERS



* X 8 1 9 7 5 0 1 2 7 *

[BLANK PAGE]

DO NOT WRITE ON THIS PAGE

Acknowledgement of copyright

Question 2 3dmitriuk/Shutterstock.com

Question 3 menoi/Shutterstock.com

Question 4 Image of Futurism Toaster by jsjrosa.

SQA has made every effort to trace the owners of copyright of this item and seek permissions. We are happy to discuss permission requirements and incorporate any missing acknowledgement. Please contact question.papers@sqa.org.uk.

Question 5 Vlad Kochelaevskiy/Shutterstock.com

Question 6 (Left) - MicroOne/Shutterstock.com
(Right) - HABRDA/Shutterstock.com

Question 8 Oleg Sam/Shutterstock.com

Question 9 Phonlami Photo/Shutterstock.com

Question 10 Anton Starikov/Shutterstock.com

Question 11 (Left) - Jenson/Shutterstock.com
(Right) – Rich Carey/Shutterstock.com



* X 8 1 9 7 5 0 1 2 8 *