



National
Qualifications

2018 Engineering Science Assignment

National 5

Finalised Marking Instructions

© Scottish Qualifications Authority 2018

The information in this publication may be reproduced to support SQA qualifications only on a non-commercial basis. If it is reproduced, SQA should be clearly acknowledged as the source. If it is to be used for any other purpose, written permission must be obtained from permissions@sqa.org.uk.

Where the publication includes materials from sources other than SQA (secondary copyright), this material should only be reproduced for the purposes of examination or assessment. If it needs to be reproduced for any other purpose it is the centre's responsibility to obtain the necessary copyright clearance. SQA's NQ Assessment team may be able to direct you to the secondary sources.

These marking instructions have been prepared by examination teams for use by SQA appointed markers when marking external course assessments. This publication must not be reproduced for commercial or trade purposes.



Marking instructions

Marking instructions are provided for this assessment task. In line with SQA's normal practice, they are addressed to the marker. They will also be helpful for those preparing candidates for course assessment.

Marking instructions **will not** be provided with annual assessment tasks, as candidate evidence will be submitted to SQA for external marking. They will be provided to markers and then published on the SQA website after marking is complete.

General marking principles

This information is provided to help you understand the general principles that must be applied when marking candidate responses in this assignment. These principles must be read in conjunction with the detailed/specific marking instructions, which identify the key features required in candidate responses.

- a. Marks for each candidate response must **always** be assigned in line with these general marking principles and the specific marking instructions for this assessment.
- b. Marking should always be positive. This means that, for each candidate response, marks are accumulated for the demonstration of relevant skills, knowledge and understanding: they are not deducted from a maximum on the basis of errors or omissions.
- c. If a specific candidate response is not covered by either the general marking principles or detailed marking instructions, you must seek guidance from your team leader.

Task		Expected answer(s)	Max mark	Additional guidance																																				
1.	a		1	<p>Correctly connected logic gates as per circuit diagram with input devices that will allow testing (1 mark)</p> <p>Using a pre-built model without evidence of candidate simulation/construction (0 marks)</p>																																				
1.	b	<table border="1"> <thead> <tr> <th>A</th> <th>B</th> <th>C</th> <th>Z</th> </tr> </thead> <tbody> <tr> <td>0</td> <td>0</td> <td>0</td> <td>0</td> </tr> <tr> <td>0</td> <td>0</td> <td>1</td> <td>1</td> </tr> <tr> <td>0</td> <td>1</td> <td>0</td> <td>0</td> </tr> <tr> <td>0</td> <td>1</td> <td>1</td> <td>1</td> </tr> <tr> <td>1</td> <td>0</td> <td>0</td> <td>1</td> </tr> <tr> <td>1</td> <td>0</td> <td>1</td> <td>1</td> </tr> <tr> <td>1</td> <td>1</td> <td>0</td> <td>0</td> </tr> <tr> <td>1</td> <td>1</td> <td>1</td> <td>1</td> </tr> </tbody> </table>	A	B	C	Z	0	0	0	0	0	0	1	1	0	1	0	0	0	1	1	1	1	0	0	1	1	0	1	1	1	1	0	0	1	1	1	1	1	<p>Correct actual results in column Z (1 mark)</p> <p>Markers should take account of simulation/construction evidence (including behaviour of input components) from 1a for FTE</p> <p>No evidence of simulation/construction in 1a (0 marks)</p>
A	B	C	Z																																					
0	0	0	0																																					
0	0	1	1																																					
0	1	0	0																																					
0	1	1	1																																					
1	0	0	1																																					
1	0	1	1																																					
1	1	0	0																																					
1	1	1	1																																					

Task	Expected answer(s)	Max mark	Additional guidance
2. a	<div style="display: flex; justify-content: space-around; align-items: center;"> <div data-bbox="315 320 728 970"> <p>Flowchart_1</p> <pre> graph TD Start([Start]) --> Input0{Input0 On?} Input0 -- Y --> Set67[Set: Output6 On, Output7 On] Set67 --> Input1{Input1 On?} Input1 -- Y --> Set6Off[Set: Output6 Off] Set6Off --> Wait5s[Wait 5 s] Wait5s --> Set7Off[Set: Output7 Off] Set7Off --> Input0 Input0 -- N --> Input0 Input1 -- N --> Input0 </pre> </div> <div data-bbox="741 826 1368 1262"> </div> </div>	5	<p>Electronic circuit</p> <p>all correct components selected and wiring attempted (1 mark)</p> <p>correct wiring, microcontroller pin connections, component orientations and component values (1 mark)</p> <p>Flowchart</p> <p>correct symbols (to the software) with feedback loops and connections (1 mark)</p> <p>all correct pin numbers (matching microcontroller connections), pin states, decisions and time delays (to the software) (1 mark)</p> <p>Integration of flowchart and electronic circuit (1 mark)</p> <p>Use of a pre-built model/drivers etc. without evidence of candidate simulation/construction (0 marks)</p> <p>Note: Allow use of alternative microcontrollers other than 8-pin Note: Allow use of alternative pin numbers appropriate to hardware used Note: ignore battery orientation</p>

Task		Expected answer(s)				Max mark	Additional guidance
2.	b					5	<p>Must be descriptive responses. Not yes, no or “it worked” on its own.</p> <p>Maximum 3 marks for actual results from each test Maximum 2 marks for amendments</p> <p>Markers should take account of simulation/construction evidence from 2a and 2c and allow FTE</p> <p>FTEs should also be applied within each row</p> <p>Identification of motor turning on and LED not turning on. Both components must be referred to. (1 mark)</p> <p>Resistor value reduction inferred (1 mark)</p> <p>Identification of LED turning off first followed by the motor after 5 seconds. Both components and time delay must be referred to. (1 mark)</p> <p>Pin6 low and pin7 low amendment (1 mark)</p> <p>Correct operation of sequence repeating itself/looping back to start (1 mark)</p> <p>(Amendment if necessary for sequence repeating (1 mark))</p>
		Planned test	Expected result	Actual result	Amendments made		
		Test 1 Activate the start switch	The 6V motor should start turning and the LED should turn on	The motor turns. The LED did not turn on	Reduced the value of the fixed resistor		
		Test 2 Activate the stop switch	The 6V motor should stop turning and then after 5 seconds the LED should turn off	The LED turned off and then after 5 seconds the motor stopped	I swapped the position of pin6 low and pin7 low		
Test 3 Repeat tests 1 and 2	The sequence should loop back to the start and repeat	The sequence repeated	No amendments required				

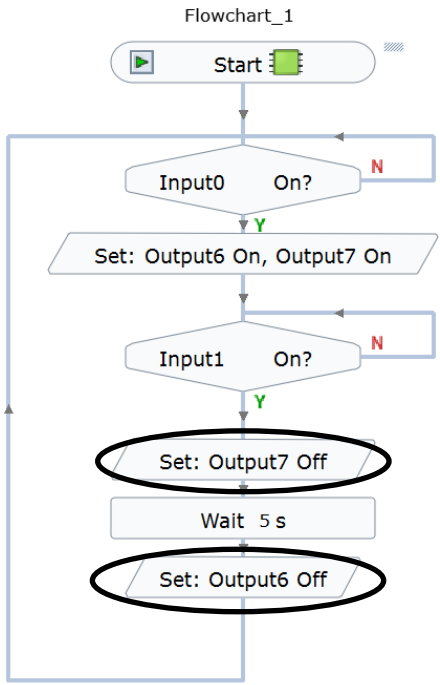
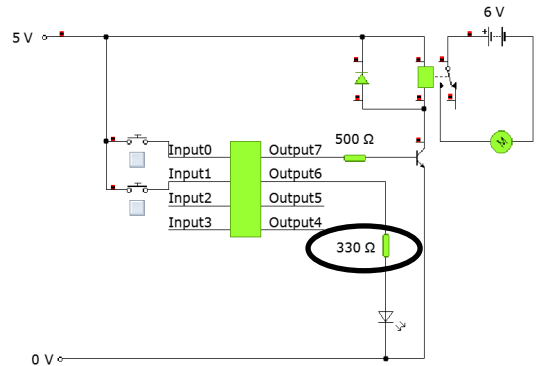
Task	Expected answer(s)	Max mark	Additional guidance
2. c	<p>Flowchart_1</p>  <pre> graph TD Start([Start]) --> Input0{Input0 On?} Input0 -- N --> Input0 Input0 -- Y --> Set67[/Set: Output6 On, Output7 On/] Set67 --> Input1{Input1 On?} Input1 -- N --> Input0 Input1 -- Y --> Set7Off[/Set: Output7 Off/] Set7Off --> Wait5s[Wait 5 s] Wait5s --> Set6Off[/Set: Output6 Off/] Set6Off --> Input0 </pre> <p>5 V</p>  <p>0 V</p>	2	<p>Markers should take account of simulation/construction evidence from 2a and testing evidence from 2b. Allow for FTE.</p> <p>One mark per amendment either from initial flowchart/circuit in 2a or from described amendment in test table 2b (maximum 2 marks)</p> <p>If no amendments are made (0 marks)</p>

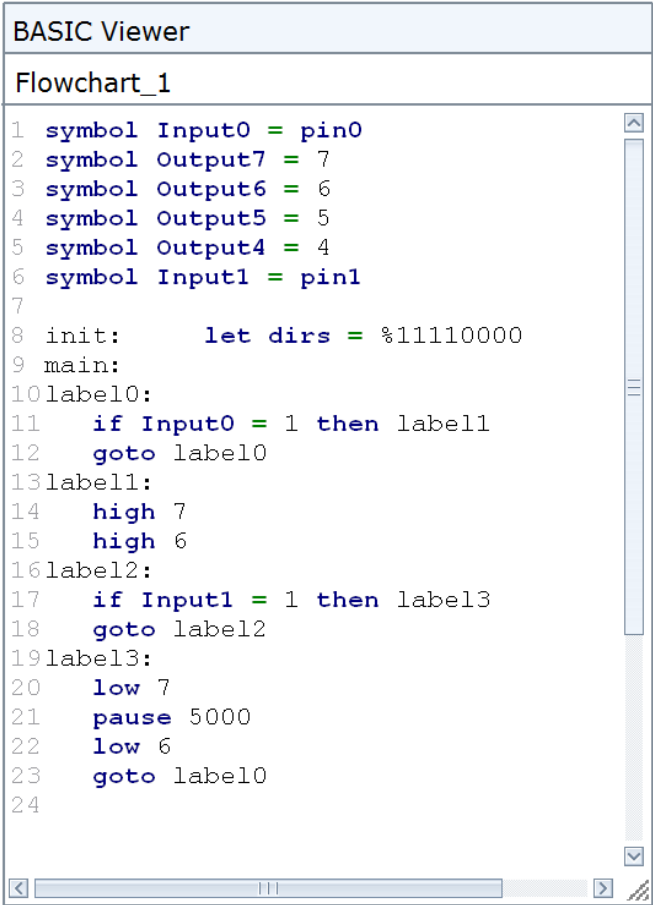
Task	Expected answer(s)	Max mark	Additional guidance
2. d	 <pre> BASIC Viewer Flowchart_1 1 symbol Input0 = pin0 2 symbol Output7 = 7 3 symbol Output6 = 6 4 symbol Output5 = 5 5 symbol Output4 = 4 6 symbol Input1 = pin1 7 8 init: let dirs = %11110000 9 main: 10label0: 11 if Input0 = 1 then label1 12 goto label0 13label1: 14 high 7 15 high 6 16label2: 17 if Input1 = 1 then label3 18 goto label2 19label3: 20 low 7 21 pause 5000 22 low 6 23 goto label0 24 </pre>	1	<p>Correct code to fully match the flowchart in part 2c (1 mark)</p> <p>Accept manually written or automatically generated</p> <p>Any high level language acceptable</p>

Task		Expected answer(s)	Max mark	Additional guidance
2.	e	<p>i. The motor switched on when the start switch was activated. By changing the value to 330 ohms it enabled the LED to light when the pin was high and now fully satisfies specification point 1.</p> <p>ii. When I activated the stop switch the motor turned off first and then the LED after 5 seconds fully satisfying specification point 2.</p> <p>iii. The system was tested a number of times with it looping back to the start each time ready to be tested again.</p> <p>Comment on the overall effectiveness of the solution in relation to the car wash environment, such as: water proofing, insufficient power of the motor, etc.</p> <p>Program repeats which means that many cars can be washed efficiently.</p>	4	<p>Description of whether specification point 1 was met with justification, referring to motor and LED (1 mark)</p> <p>Description of whether specification point 2 was met with justification, referring to motor and LED and time delay (1 mark)</p> <p>Description of whether specification point 3 was met with justification (1 mark)</p> <p>Evaluative comment on the overall system in terms of car wash environment or possible improvements (1 mark)</p> <p>Apply FTE from 2c</p>

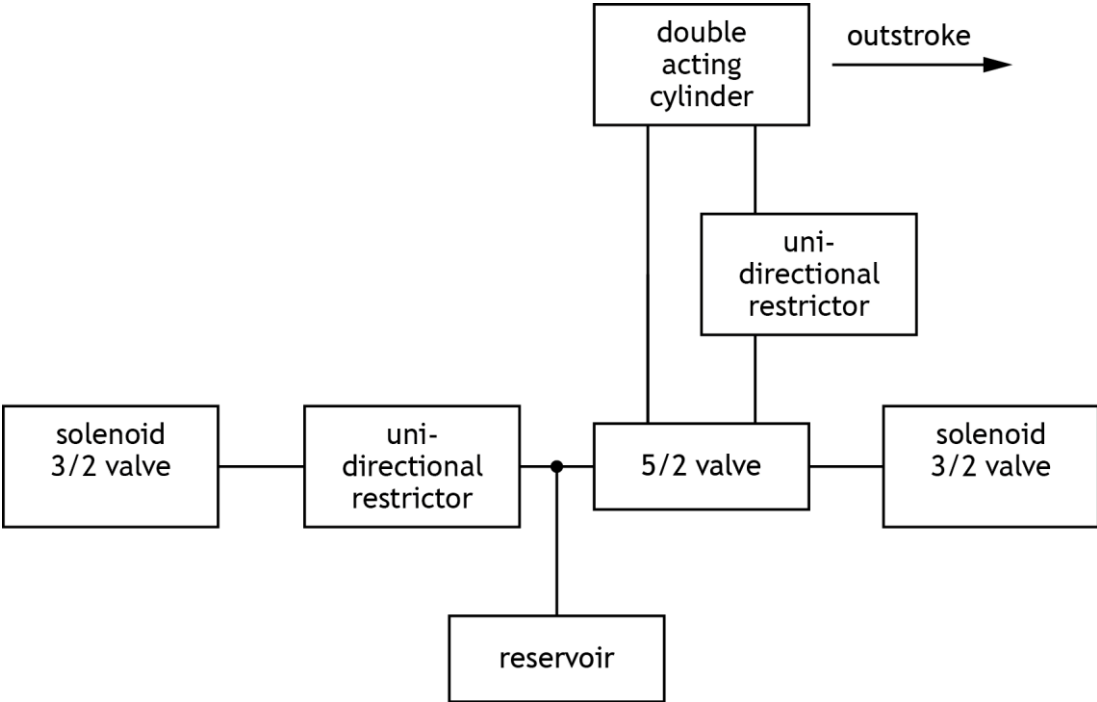
Task	Expected answer(s)	Max mark	Additional guidance
3. a		6	<p>Block diagram, circuit diagram (or a hybrid) or constructed/simulated. All are acceptable.</p> <p>Components identified by name or use of component symbols</p> <p>Connections between components must be shown. Ignore line types. Port to port piping is not required.</p> <p>Double acting cylinder with direction of outstroke indicated correctly connected to 5/2 valve (1 mark)</p> <p>Uni-directional restrictor to slow outstroke of cylinder on exhaust (1 mark)</p> <p>Time delay before piston outstrokes (also accept if time delay is on outstroke pipe) (1 mark)</p> <p>Arrangement of reservoir and (uni-directional) restrictor to create adjustable time delay (1 mark)</p> <p>2 x 3/2 valves to cause outstroke and instroke (1 mark)</p> <p>2 x solenoid actuators (1 mark)</p>

Task		Expected answer(s)	Max mark	Additional guidance
3.	b	<p>Diaphragm actuator:</p> <ol style="list-style-type: none"> 1. It is more suitable because it is safe in the wet environment unlike the electrical actuator which could produce an electric shock. 2. Source of pneumatics already on site, reducing the cost of implementation. <p>Electrical actuator:</p> <ol style="list-style-type: none"> 1. Could be operated by a microcontroller, allowing for different wash cycles to be completed. 2. Flexibility of control by using different sensors to detect the car 	2	<p>Reason 1 - characteristic selected and justified in context (1 mark)</p> <p>Reason 2 - characteristic selected and justified in context (1 mark)</p> <p>Either actuator could be selected</p>

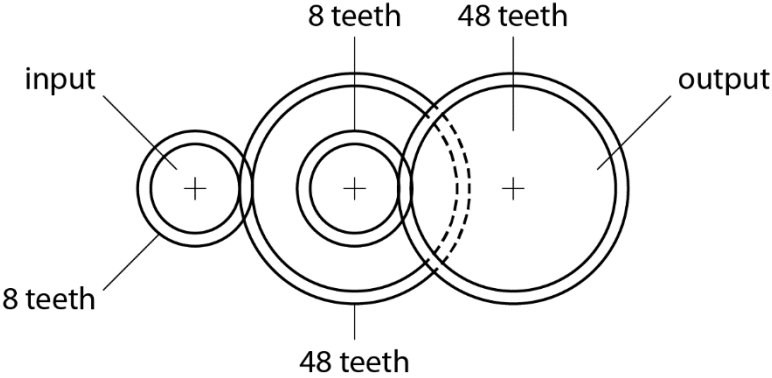
Task	Expected answer(s)	Max mark	Additional guidance
4. a		2	<p>Compound gear train, labelling input or output or implied (eg through inclusion of motor or calculations) (1 mark)</p> <p>All gear sizes shown that will give a speed reduction of at least a factor of 25 (1 mark)</p> <p>If simple gear train shown with a speed reduction of at least a factor of 25 (1 mark only)</p> <p>If simulated/constructed (0 marks)</p> <p>Only accept use of worm and worm wheel as part of compound gear train.</p>

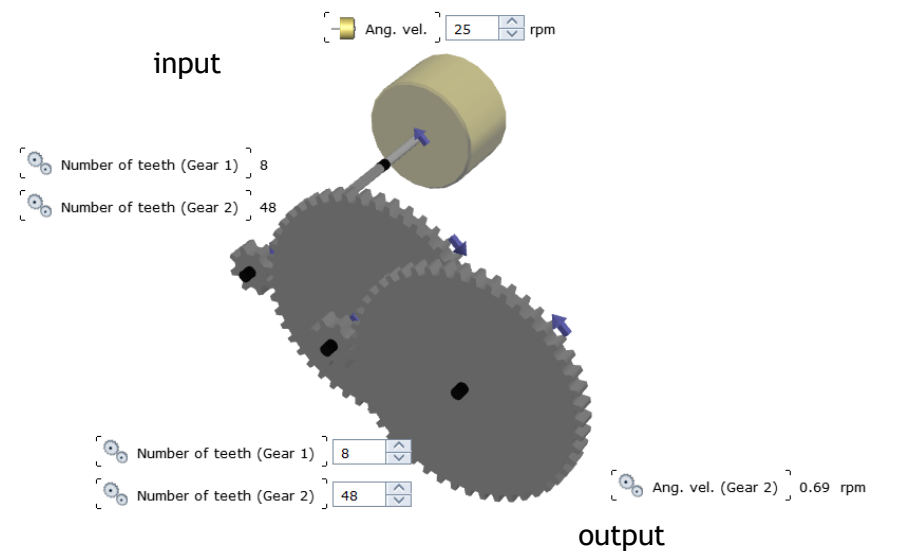
Task	Expected Answer(s)	Max mark	Additional Guidance
4. b	 <p>The image shows a 3D CAD model of a compound gear train. An input shaft (yellow) is connected to a gear with 8 teeth. This gear meshes with a gear with 48 teeth. This 48-tooth gear is on the same shaft as a smaller gear with 8 teeth. This smaller gear meshes with a final output gear with 48 teeth. The input shaft's angular velocity is set to 25 rpm. The output gear's angular velocity is shown as 0.69 rpm. The number of teeth for each gear is also displayed in the simulation interface.</p>	2	<p>Compound gear train simulated or constructed, labelling input or output or implied (eg through inclusion of motor) (1 mark)</p> <p>All gear sizes shown to match the design in 4a or evidence of VR (eg graph) that proves teeth numbers (1 mark)</p>

Task		Expected answer(s)				Max mark	Additional guidance	
4.	c	Planned test		Expected result		Actual result		
			Input speed	Output speed	Input speed	Output speed		
		Measure the input speed and output speed of the gear system	25 revs min ⁻¹ or 25 turns	No more than 1 revs min ⁻¹ or 1 turns	25 revs min ⁻¹ or 25 turns	0.69 revs min ⁻¹ or 0.69 turns	1	Complete table showing actual results from simulation in 4b (1 mark) No teeth numbers indicated on 4a or 4b (0 marks) No evidence of simulation/ construction in 4b (0 marks) Unit not required Accept number of turns

Task		Expected answer(s)	Max mark	Additional guidance
4.	d	<p>i. The input speed of the motor was set to 25 revs min⁻¹. The output speed was measured as 0.69 revs min⁻¹ which gave a reduction in speed of 36 times. This is a greater reduction than was required. The gear system meets specification point 1.</p> <p>ii. I designed my gear system using a compound gear train. This means that it should fit into a compact space as required, meeting specification point 2.</p>	2	<p>Description of whether specification point 1 was met with justification, referring to VR/speeds/results from 4c (1 mark)</p> <p>Description of whether specification point 2 was met with justification of space, referring to compound arrangement, number of gears or size of gears (1 mark)</p> <p>Note: evaluation can take place based on design in 4a without evidence of simulation/construction</p>

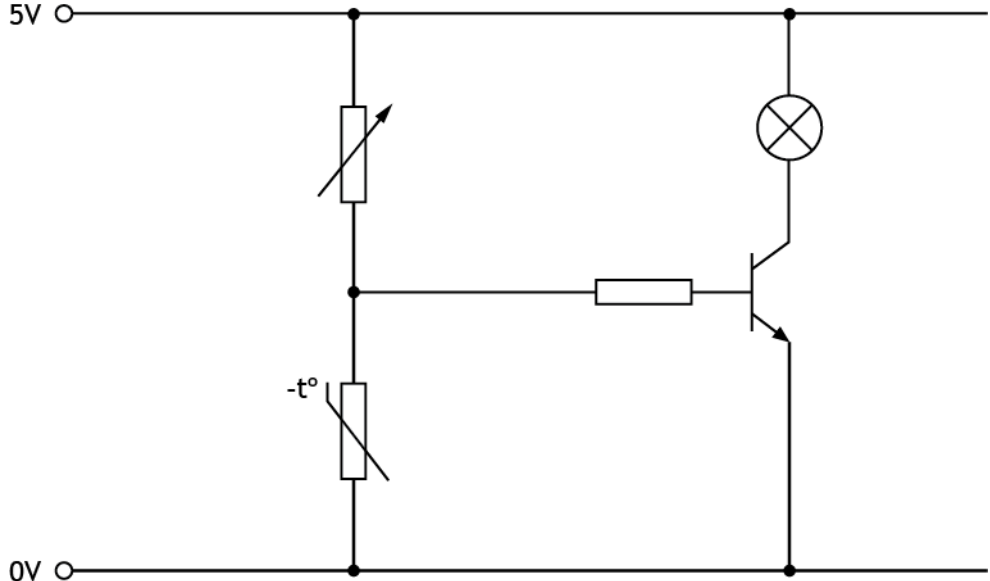
Task	Expected Answer(s)	Max mark	Additional Guidance
5. a		3	<p>Selecting a thermistor with use of correct symbol (ignore -t) (1 mark)</p> <p>Selecting a variable resistor with use of correct symbol (1 mark)</p> <p>Correct position and wiring of components to create cold sensor (1 mark)</p> <p>Values of components not required</p> <p>Accept simulation</p>

Task		Expected Answer(s)		Max mark	Additional Guidance
5.	b			6	<p>Note: correct tests/expected results from specification</p> <p>Test for a decrease in temperature (1 mark)</p> <p>Expected result for decrease test in terms of V_{out} increasing or lamp/heater on (1 mark)</p> <p>Test for an increase in temperature (1 mark)</p> <p>Expected result for increase test in terms of V_{out} decreasing or lamp/heater off (1 mark)</p> <p>Test altering the variable resistor and changing the temperature (1 mark)</p> <p>Expected result for altering variable in terms of V_{out} changing or lamp/heater on/off at different temperatures (1 mark)</p> <p>Responses must be descriptive and describe what is being tested.</p> <p>Note: do not accept “brighter” or “dimmer”</p>
		Planned test	Expected result		
		Decrease the temperature	The voltage (V_{out}) will increase or Lamp/heater on		
		Increase the temperature	The voltage (V_{out}) will decrease or Lamp/heater off		
Adjust the value of the variable resistor and adjust the temperature	Lamp/heater will switch on/off at a different temperature				
Increase value of variable resistor and lower the temperature	Lamp/heater turns on/increase of voltage (V_{out})				
Decrease value of variable resistor and raise the temperature	Lamp/heater turns off/decrease of voltage (V_{out})				

Task		Expected Answer(s)	Max mark	Additional Guidance
6.	a	<pre> graph LR car --> box[end of wash cycle] box --> red_light[red light] box --> green_light[green light] </pre>	2	<p>Car input identified and in the correct position with arrow (1 mark)</p> <p>Red and green (light) outputs identified and in the correct position with arrow(s) (1 mark)</p> <p>Note: all correct inputs and outputs but without arrows (1 mark)</p> <p>Ignore extra boxes or words</p>

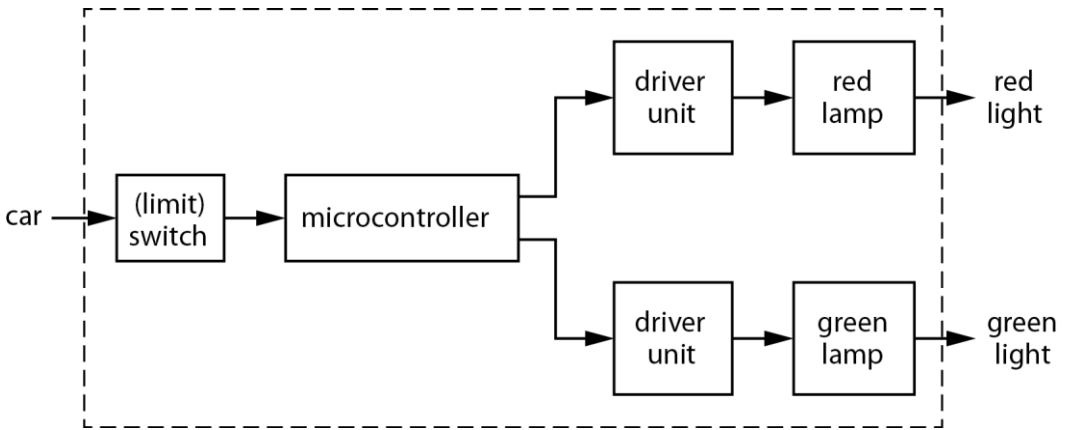
Task	Expected Answer(s)	Max mark	Additional Guidance
6. b		5	<p>Switch connected to microcontroller in correct position (1 mark) (switch as feedback sensor not accepted)</p> <p>Driver(s) connected to microcontroller (1 mark)</p> <p>Lamp in correct position (red output) (1 mark)</p> <p>Lamp in correct position (green output) (1 mark)</p> <p>System boundary around sub-systems only (1 mark)</p> <p>Do not accept light, bulb or LED instead of “lamp”</p> <p>Ignore extra sub-systems</p> <p>If no arrows shown assume left to right</p>

[END OF MARKING INSTRUCTIONS]