



National 5
Coursework
Assessment Task



National 5 Engineering Science Assignment Assessment task: Car Wash

This document provides information for teachers and lecturers about the coursework component of this course in terms of the skills, knowledge and understanding that are assessed. It **must** be read in conjunction with the course specification.

Valid for session 2017-18 only.

The information in this publication may be reproduced in support of SQA qualifications only on a non-commercial basis. If it is reproduced, SQA must be clearly acknowledged as the source. If it is to be reproduced for any other purpose, written permission must be obtained from permissions@sqa.org.uk.

Where this publication includes material for which SQA does not own the copyright, this material must only be reproduced on a non-commercial basis for the purposes of instruction in an educational establishment. If it is to be reproduced for any other purpose, it is the user's responsibility to obtain the necessary copyright clearance from the copyright owner. The acknowledgements page lists the owners of copyright items that are not owned by SQA.

This edition: January 2018 (version 1.0)

© Scottish Qualifications Authority 2018

Contents

Introduction	1
Instructions for teachers and lecturers	2
Instructions for candidates	5

Introduction

This document contains instructions for teachers and lecturers and instructions for candidates for the National 5 Engineering Science assignment. It must be read in conjunction with the course specification.

This assignment has 50 marks out of a total of 160 marks available for the course assessment.

This is one of two course assessment components. The other component is a question paper.

Instructions for teachers and lecturers

SQA will publish a new assessment task on the secure website each academic year. This task is valid for session 2017-18 only. Once complete, assignment responses are sent to SQA to be marked.

The assignment must be conducted under a high degree of supervision and control, which means:

- ◆ all candidates must be within direct sight of the teacher or lecturer
- ◆ interaction with other candidates must not occur
- ◆ e-mail, the internet and mobile phones must not be accessed
- ◆ candidates must complete their work independently (ie no group work is permitted)
- ◆ display materials, which might provide assistance, must be removed or covered up
- ◆ with no interruption for learning and teaching
- ◆ in a classroom environment

Time

Candidates have 8 hours to complete the assignment, starting at an appropriate point in the course after all content has been delivered. Once candidates begin, they must continue in each subsequent class period until the permitted time allocation has been used up.

Teachers and lecturers have a responsibility to manage candidates' work, ie distributing it at the beginning and collecting it at the end of each session, and storing it securely in-between. This does not count towards the total time permitted for candidates to complete the assignment.

Resources

This is a closed-book assessment. Candidates must not have access to learning and teaching materials, the internet, notes, exemplar materials, resources on classroom walls or anything similar. However, use of SQA's National 5 Engineering Science Data Booklet is permitted.

Each assessment task includes instructions and details of any equipment or materials required for the assignment. Candidates can also use normal classroom equipment, software and hardware (such as drawing instruments, pneumatics, mechanisms and electronics kit, simulation software, and PCs to run the software) to complete the tasks.

There may be instances where restriction of internet/network use is prohibited (eg a local authority-managed network with specific limitations, software that is web-based, or something similar), however, it remains the teacher or lecturer's professional responsibility to make every effort to meet the assessment conditions.

Reasonable assistance

Candidates must progress through each stage of the assignment without any teacher or lecturer intervention or guidance, having acquired the skills earlier in the course.

Once the assignment has been completed, it must not be returned to candidates for further work. Teachers and lecturers must not provide feedback to candidates or offer opinion on the perceived quality or completeness of the assignment response, at any stage.

Reasonable assistance may be provided to support candidates with the following aspects of their assignment:

- ◆ Printing, collating, stapling and labelling their evidence to ensure it is in the format specified by SQA.
- ◆ Ensuring candidates have all the materials and equipment required to complete the assignment.
- ◆ Understanding the information outlined in these instructions.

Evidence

All candidate evidence (whether created manually or electronically) must be submitted to SQA in paper-based format.

Each task details what evidence is required and how many pages are expected. This is a guide to ensure that candidates do not produce too much work or spend too long on a single task.

Alteration or adaptation

The assignment must not be altered, adapted or modified in any way (this would include moving the content of the assignment into a different format or workbook). All candidates must undertake the assignment exactly as it is provided.

Submission

Each piece of work must be labelled with the task number, eg task 2a, and the back of each page must be clearly labelled with candidate details.

Volume

There is no word or page count.

Specific instructions for teachers and lecturers: 2017-18 Assignment

Teachers and lecturers must ensure that these specific instructions are followed. Candidates must be made aware of the assessment conditions and know what they should do for each task.

This assignment has six tasks, all of which are mandatory and can be completed in the order presented or in an order that would help to manage classroom equipment.

Each task has a notional time allocated to it. This is not mandatory and is provided as an indication of how long candidates should spend on the task.

All tasks should be completed on the pro forma provided, or evidence printed (screenshots or images must be **clear and easy to read**) on A4 single sided paper with the task number clearly labelled.

Task 1 (2 marks)

Notional time: 30 minutes

Task 2 (17 marks)

Notional time: 2 hours 30 minutes

Task 3 (8 marks)

Notional time: 1 hour

Task 4 (7 marks)

Notional time: 2 hours

Evidence for 4a, designing, must not be produced by computer simulation.

Task 5 (9 marks)

Notional time: 1 hour 30 minutes

Task 6 (7 marks)

Notional time: 30 minutes

Data sheets are provided for use by candidates when completing this year's assignment. No other resource material is permitted other than SQA's National 5 Engineering Science Data Booklet.

Please note that print-outs of electronically-generated evidence (eg simulations and coding) are included in the expected number of pages for each task, and are part of the submission to SQA.

Instructions for candidates

This assessment applies to the assignment for National 5 Engineering Science.

This assignment has 50 marks out of a total of 160 marks available for the course assessment. It assesses the following skills, knowledge and understanding:

- ◆ demonstrating engineering science skills and creativity
- ◆ analysing engineering problems
- ◆ designing and building/simulating solutions to engineering problems
- ◆ testing and evaluating solutions to engineering problems

This is a closed-book assessment. Your teacher or lecturer will let you know how the assessment will be carried out and any required conditions for doing it.

In this assessment, you have to:

- ◆ analyse a problem
- ◆ design a solution to the problem
- ◆ simulate or construct your solution
- ◆ test your solution
- ◆ evaluate your work

Unless otherwise instructed, you should complete all of the tasks in the order presented. You will be allowed 8 hours to complete the assignment, excluding the time required to set up and clear away any equipment you will need, and for any printing that is required.

The assignment has six tasks, with marks allocated as follows:

Task 1 – 2 marks: building and testing a solution (electronics) for the car sensor.
(building = 1 mark, testing = 1 mark)

Task 2 – 17 marks: building, testing, evaluating and designing a solution (electronics and programmable control) for the cleaning brushes - rotational movement.
(building = 7 marks, testing = 5 marks, evaluating = 4 marks, designing a solution = 1 mark)

Task 3 – 8 marks: designing a solution (pneumatics) for the cleaning brushes - horizontal movement.
(designing = 6 marks, evaluating = 2)

Task 4 – 7 marks: designing, testing, building a solution and evaluation (mechanisms) for the cleaning brushes - speed control.
(designing = 2 marks, testing = 1 mark, building = 2 marks, evaluating = 2 marks)
Evidence for 4a, designing, must **not** be produced by computer simulation.

Task 5 – 9 marks: designing and testing a solution (electronics) for the water heater.
(designing = 3 marks, testing = 6 marks)

Task 6 – 7 marks: analysing a solution (electronics) for the end of wash cycle alert.
(analysis = 7 marks)

Data Sheets are provided for your use when completing this year's assignment. No other resource material is permitted other than SQA's National 5 Engineering Science Data Booklet.

For each task, you will be provided with an engineering science brief.

Submitting your work

Your teacher or lecturer will let you know the approximate amount of time to spend on each task, along with an indication of the number of pages of evidence that you should produce.

Each piece of your work must be labelled with the task number (eg task 2a) and the back of each page must be clearly labelled with your:

- ◆ name
- ◆ date of birth
- ◆ Scottish Candidate Number (SCN)
- ◆ centre name
- ◆ centre number

Candidate Data Sheets - Car Wash Assignment

These data sheets are provided for use by candidates when completing this year's assignment. No other resource material is permitted other than the Data Booklet.

Electronic components

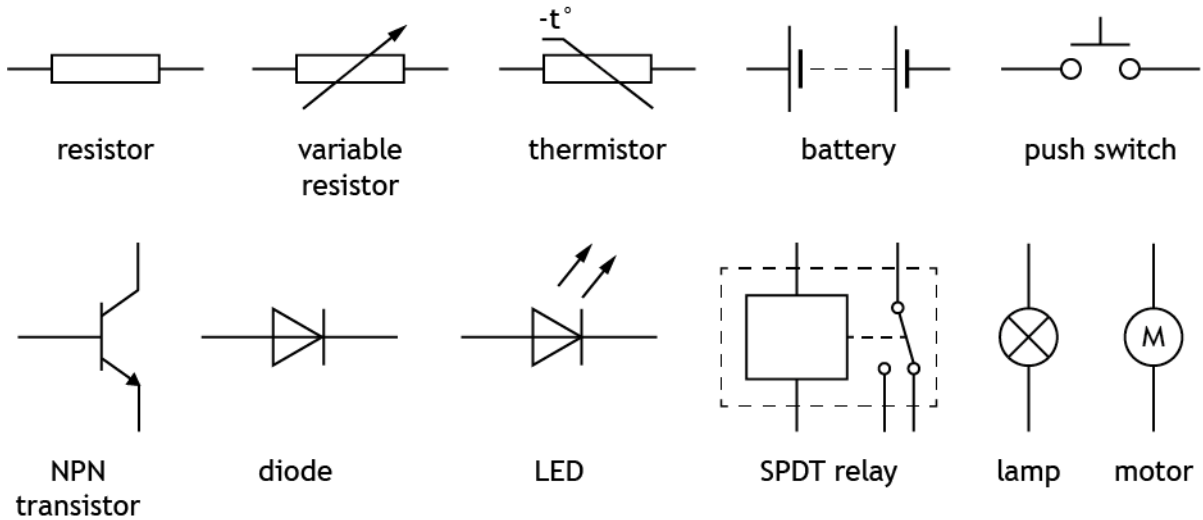

Logic gates

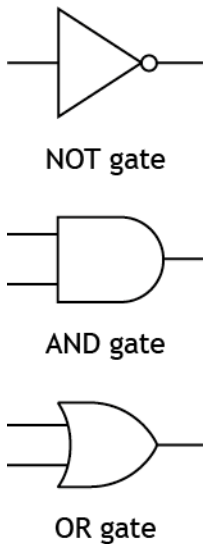

IC pinout diagrams

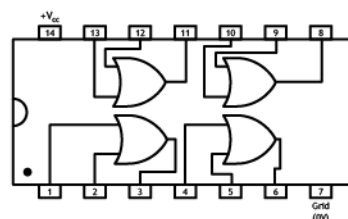
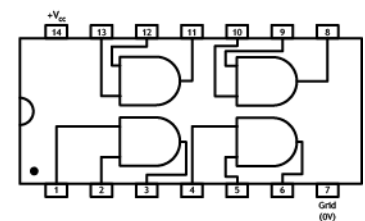
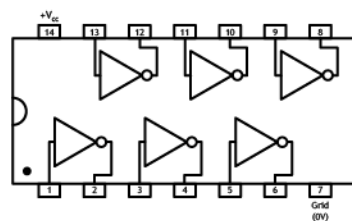

Thermistor graph

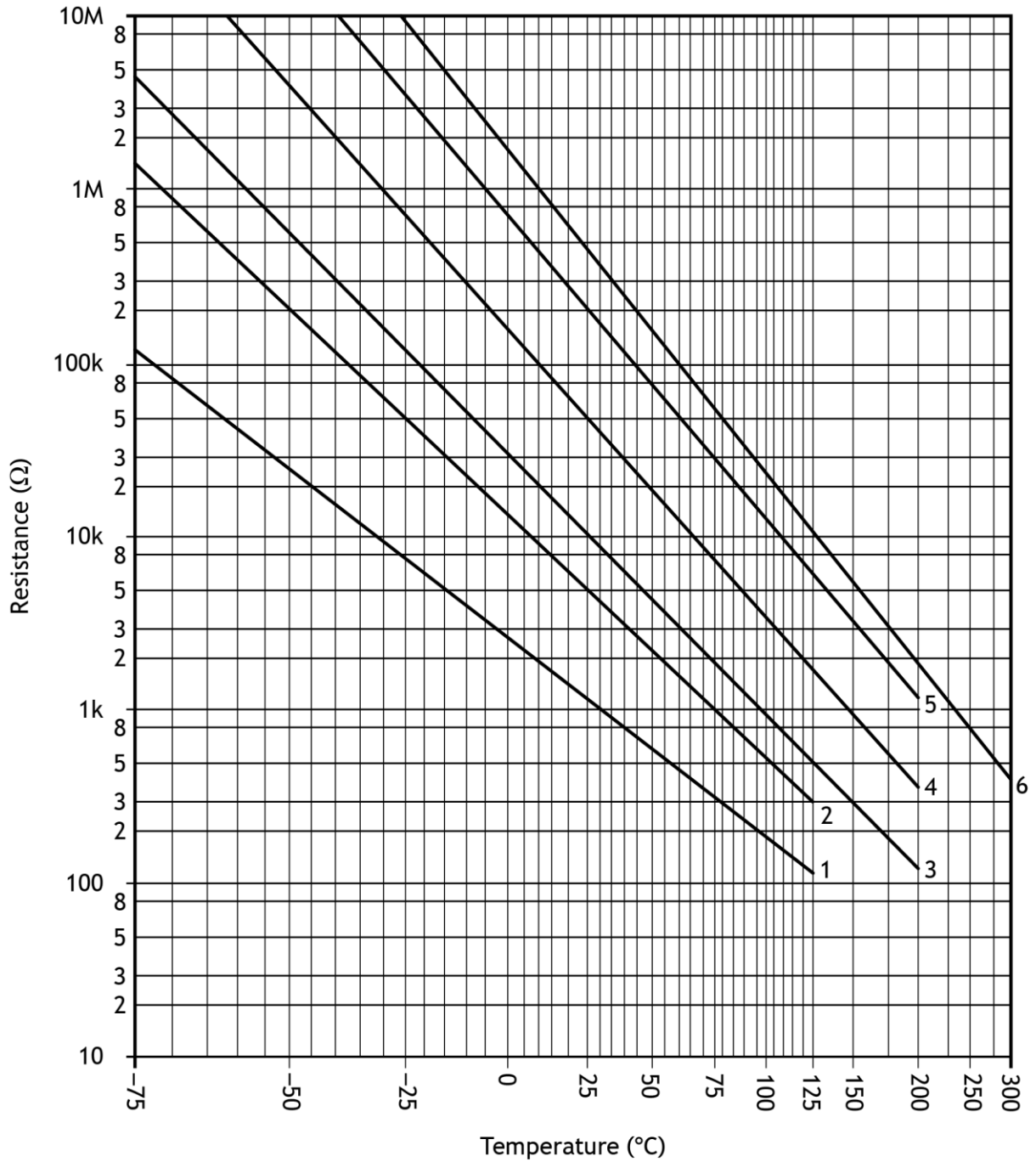

Pneumatic components

Actuators



solenoid



diaphragm



spring
return



pilot air

Valves

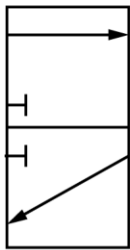

3/2 valve

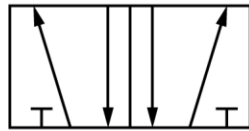

5/2 valve



main air



exhaust

Components and cylinders

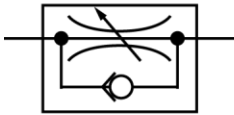

unidirectional
restrictor



reservoir

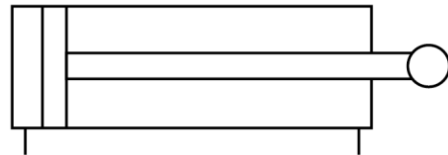

double acting cylinder

Car wash

A team of engineers is involved in several tasks during the development of a new car wash.

These tasks include the development of proposals for the following sub-systems:

Task 1 - car sensor sub-system

Task 2 - cleaning brushes - rotational movement sub-system

Task 3 - cleaning brushes - horizontal movement sub-system

Task 4 - cleaning brushes - speed control sub-system

Task 5 - water heater sub-system

Task 6 - end of wash cycle alert sub-system



Task 1 - car sensor sub-system

The car wash should only operate when a master switch A is on (logic 1) and a sensor B detects a car has driven into the correct position (logic 0). The car wash can also be tested by pressing an override switch C (logic 1).

The design for a logic circuit to control the operation of the car wash is shown below.

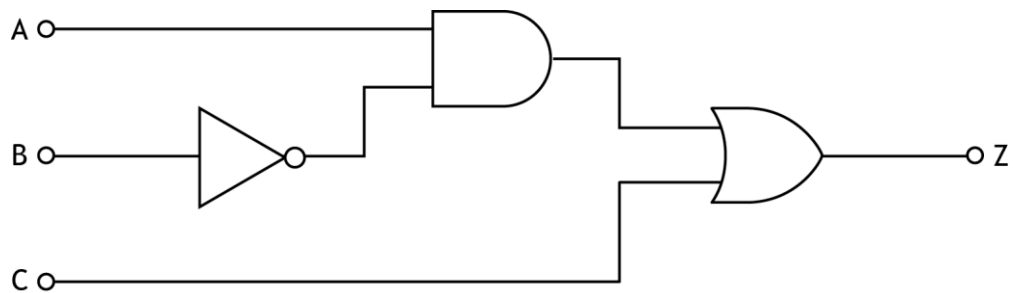

- 1a Simulate or construct the logic circuit shown above. You must include input devices to allow for testing.

Print the evidence (screenshots or images must be clear and easy to read) on A4 single sided paper with the task number clearly labelled.

(1 mark)

Task 1 - car sensor sub-system (continued)

- 1b Test your simulated or constructed circuit and complete the truth table below with your results for output Z.

(1 mark)

A	B	C	Z
0	0	0	
0	0	1	
0	1	0	
0	1	1	
1	0	0	
1	0	1	
1	1	0	
1	1	1	

Task 2 - cleaning brushes - rotational movement sub-system

Cleaning brushes are required to spin over the car during the cleaning process.

An electronic engineer has designed the flowchart and circuit shown below as a possible solution. The pin numbers used to connect the circuit to the microcontroller are shown in the table below.

- 2a Simulate or construct the flowchart and electronic circuit integrated together **as shown**. A microcontroller of an alternative size may be used but the pin numbers must match the connections given.

Print the evidence (screenshots or images must be **clear** and **easy** to read) on A4 single sided paper with the task number clearly labelled.

(5 marks)

Input Connection	Pin	Output Connection
	7	motor
	6	LED
stop switch	1	
start switch	0	

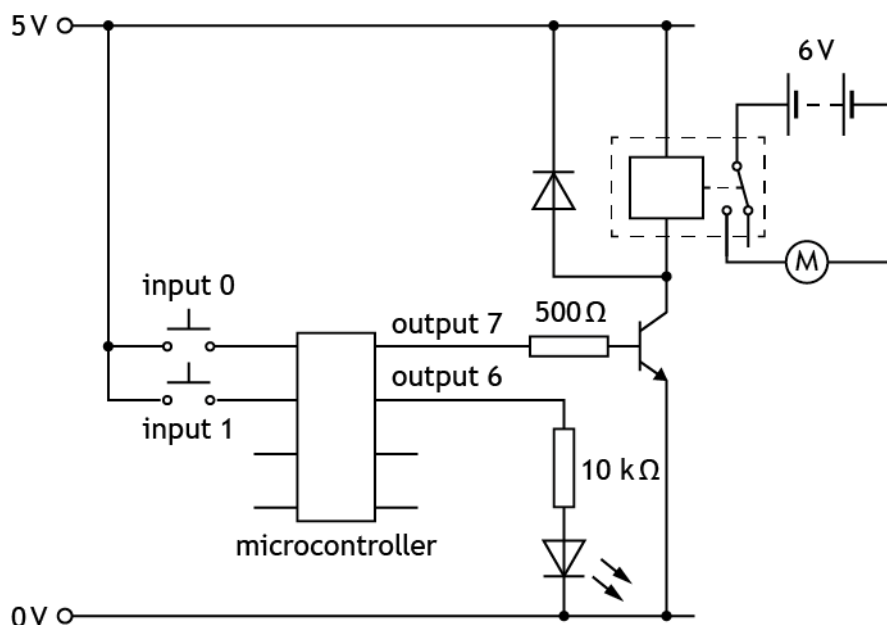
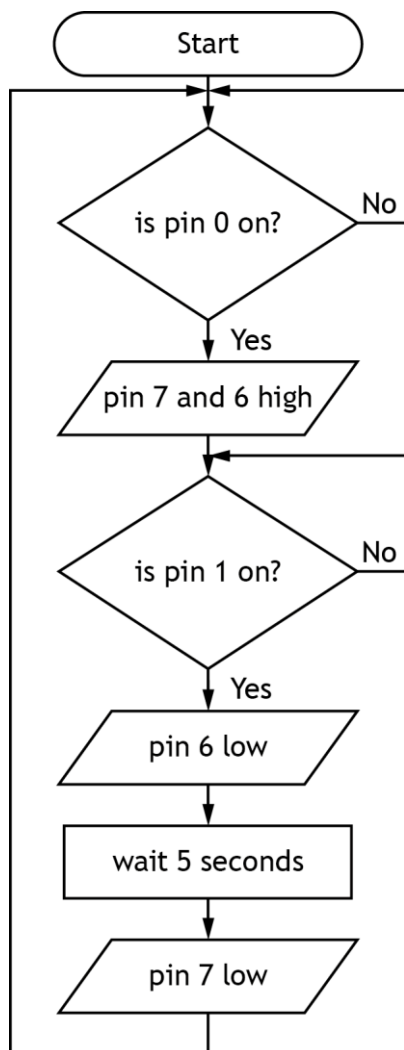

Task 2 - cleaning brushes - rotational movement sub-system (continued)

The cleaning brushes are to be operated by a microcontroller using the following specification:

- i. When a start switch is pressed an LED, protected by a resistor, switches on and an SPDT relay activates a 6V motor, spinning the cleaning brushes.
- ii. When a stop switch is pressed the motor turns off and then after a 5 second delay the LED turns off.
- iii. The sequence should then repeat.

Errors were found with the design during testing.

- 2b Complete the testing table shown on the following page, by carrying out the planned tests given, **making amendments as necessary before moving onto the next test**. You must write descriptions of the actual results you observed during testing and appropriate amendments that you made to enable the system to satisfy the specification.

If necessary, print the evidence on A4 single sided paper with the task number clearly labelled.

(5 marks)

Task 2 - cleaning brushes - rotational movement sub-system (continued)

Task 2 b (continued)

Planned test	Expected result	Actual result	Amendments made
Test 1 Activate the start switch.	The 6V motor should start turning and the LED should turn on.		
Test 2 Activate the stop switch.	The 6V motor should stop turning and then after 5 seconds the LED should turn off.		
Test 3 Repeat tests 1 and 2 to make sure the sequence is repeatable.	The sequence should loop back to the start and repeat.		

Task 2 - cleaning brushes - rotational movement sub-system (continued)

- 2c Your amended flowchart should now match the specification given at the start of task 2.

Print the evidence of your **amended flowchart and electronic circuit integrated together** after completing task 2b on A4 single sided paper with the task number clearly labelled.

Screenshots or images must be **clear and easy** to read.

(2 marks)

- 2d Produce high-level microcontroller code to fully match the function described in your amended flowchart from **task 2c**.

If necessary, print the evidence (screenshots or images must be **clear and easy** to read) on A4 single sided paper with the task number clearly labelled.

(1 mark)

Task 2 - cleaning brushes - rotational movement sub-system (continued)

2e Evaluate the performance of your **amended solution** from task 2c against the specification given in **task 2b**, by describing:

- the performance of your **amended solution** to meet **each of the three specification points**, referring to testing and any amendments that you may have made
- the overall effectiveness of your **amended solution** for use in the car wash environment

If necessary, print the evidence on A4 single sided paper with the task number clearly labelled.

(4 marks)

Task 3 - cleaning brushes - horizontal movement sub-system

A pneumatic system is to be used to move the cleaning brushes into the correct position before they start to spin. The pneumatic system must meet the following specification:

- i. When the first electrical actuator receives a signal an adjustable pneumatic time delay occurs.
- ii. After the time delay a double acting cylinder (controlled by a 5/2 valve) **outstrokes**, moving the cleaning brushes into position.
- iii. When a second electrical actuator receives a signal the double acting cylinder instrokes.
- iv. The piston's speed is controlled so that it **outstrokes slowly**.

3a Design a pneumatic system that will meet the given specification. The name of each component, valve and actuator must be identified and the direction of the piston outstroke must be indicated. Show connections between all components and valves.

If necessary, print the evidence (screenshots or images must be **clear** and **easy** to read) on A4 single sided paper with the task number clearly labelled or securely attach below.

(6 marks)

For example: a 5/2 valve could be simplified as shown below

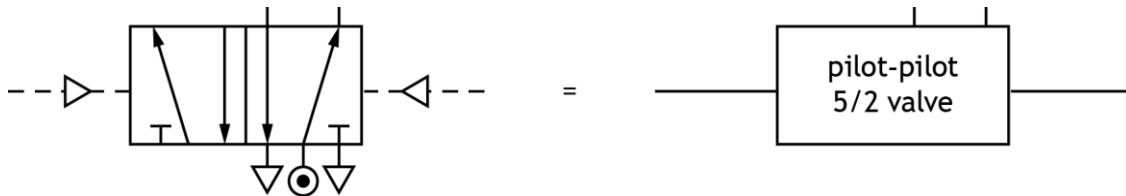

Task 3 - cleaning brushes - horizontal movement sub-system (continued)

Electrical actuators and diaphragm actuators with air bleeds were both considered to operate the pneumatic valves within the car wash.

Actuator	Characteristics
Electrical actuator	<ul style="list-style-type: none">• allows for flexibility of control• no loss of signal over a distance• safety issues with electrical signal in a wet environment• could be operated by a microcontroller
Diaphragm actuator	<ul style="list-style-type: none">• safe for use in a wet environment• air bleed may become blocked• source of pneumatics already at location• non-contact method of sensing

3b Select the most suitable actuator type for the car wash. Explain your choice, giving two reasons.

If necessary, print the evidence on A4 single sided paper with the task number clearly labelled.

(2 marks)

Selected actuator _____

Reason 1 _____

Reason 2 _____

Task 4 - cleaning brushes - speed control sub-system

The speed of the motor used to turn the cleaning brushes needs to be reduced. A compound gear train is required that will meet the following specification:

- i. Reduce the speed of the motor by **at least** a factor of 25.
- ii. Fit into a compact space inside the car wash.

4a Design a compound gear train that will meet the specification. You must identify the input and output gears and include all gear sizes.

Sketch your design below or on A4 single sided paper with the task number clearly labelled. You must **not** use simulation software to complete this task.

(2 marks)

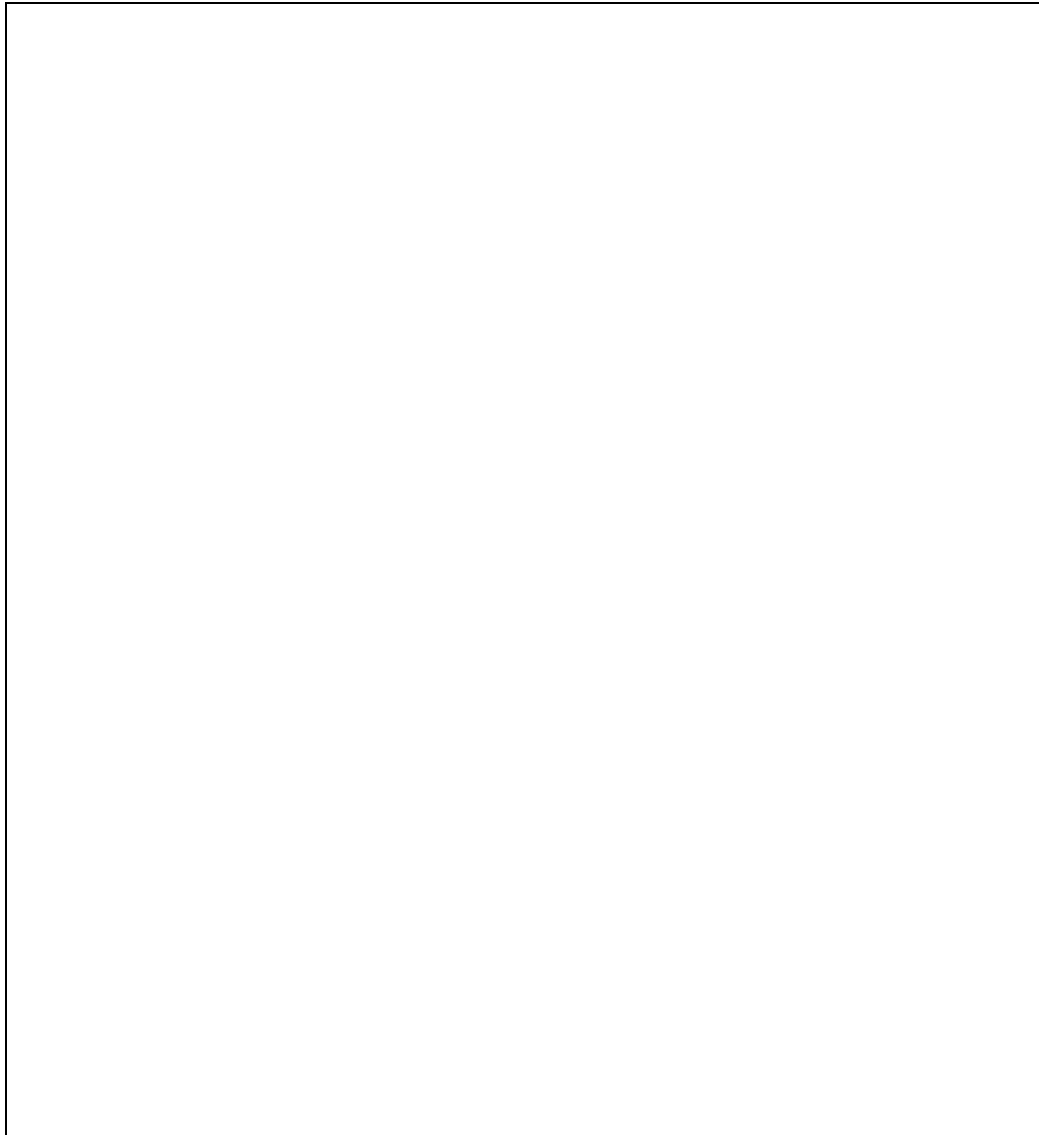

Task 4 - cleaning brushes - speed control sub-system (continued)

- 4b Simulate or construct your design from task 4a. You must identify the input and output and include all gear sizes. You must include an input component to allow for testing.

Print the evidence (screenshots or images must be **clear** and **easy** to read) on A4 single sided paper with the task number clearly labelled.

(2 marks)

- 4c Complete the testing table below by entering the actual results for the input and output speeds of the gear system that you observed during simulating or constructing.

(1 mark)

Planned test	Expected result		Actual result	
	Input speed	Output speed	Input speed	Output speed
Measure the input speed and output speed of the gear system.	25 revs min ⁻¹ or 25 turns.	No more than 1 revs min ⁻¹ or 1 turns.		

Task 4 - cleaning brushes - speed control sub-system (continued)

- 4d Evaluate your solution from **task 4b**, by describing how well the two specification points were met, referring to testing where appropriate and any amendments that you may have made.

If necessary, print the evidence on A4 single sided paper with the task number clearly labelled.

(2 marks)

Task 5 - water heater sub-system

The water used in the car wash must be heated. An input sensing circuit is required to activate a heater, meeting the following specification:

- i. When the temperature of the water falls below a set level the heater should switch on.
- ii. When the temperature of the water rises above a set level the heater should switch off.
- iii. The temperature that the heater switches on at should be adjustable.

To allow the input sensing circuit to be tested a lamp is used instead of a heater and will be activated by a transistor as shown below in task 5a.

5a Complete the circuit diagram shown below by designing a suitable **input sensing circuit** that will meet the given specification.

Component values are not required.

(3 marks)

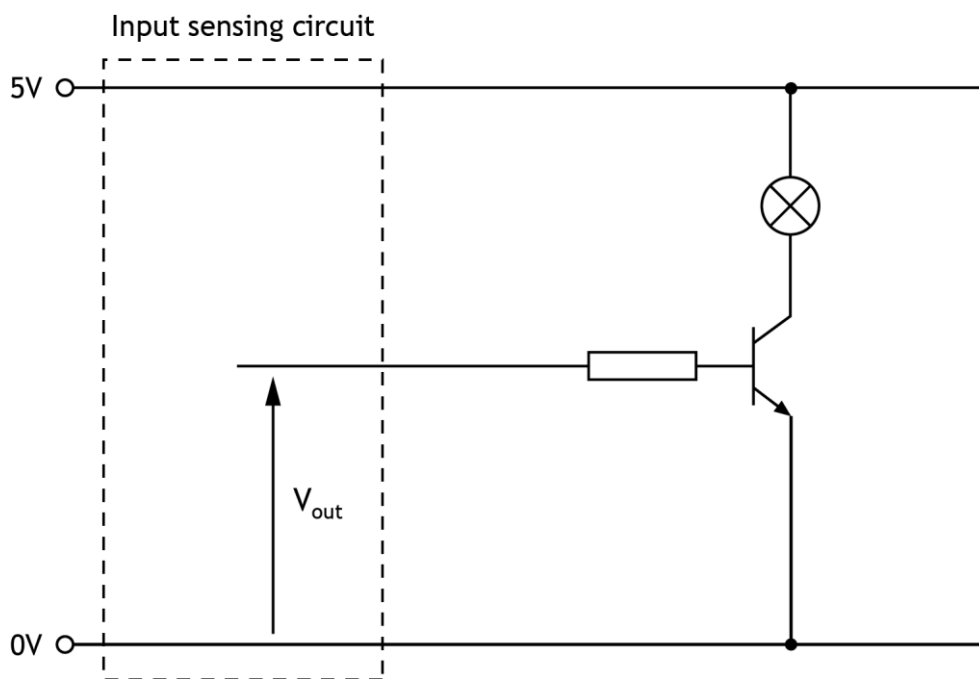

Task 5 - water heater sub-system (continued)

5b Write a test plan for the **input sensing circuit** by describing:

- three tests that could be carried out
- the results that would be expected from each test in terms of the output voltage (V_{out}) from the input sensing circuit

If necessary, print the evidence on A4 single sided paper with the task number clearly labelled.

(6 marks)

Planned test	Expected result

Task 6 - end of wash cycle alert sub-system

The specification for a microcontroller based circuit used to alert the driver that the wash cycle is about to finish is shown below.

- i. When a car is in the correct position it activates a limit switch and a red lamp will flash on and off 20 times.
- ii. After the red lamp has finished flashing it will turn off and a green lamp will turn on.

6a Complete the **system diagram** below with reference to the specification.

(2 marks)

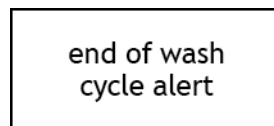

Task 6 - end of wash cycle alert sub-system (continued)

6b Complete the **sub-system** diagram below with reference to the specification. You must clearly show all sub-systems, the system boundary and interactions between sub-systems.

(5 marks)

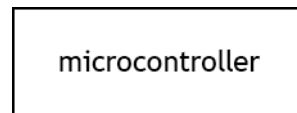

Acknowledgement of Copyright
Page 10 Nadezda Murmakova/Shutterstock.com

Administrative information

Published: January 2018

History of changes

Version	Description of change	Date

Security and confidentiality

This document can be used by practitioners in SQA approved centres for the assessment of National Courses and not for any other purpose.