



National 5
Coursework
Assessment Task



National 5 Engineering Science Assignment Finalised Marking Instructions

© Scottish Qualifications Authority 2019

These marking instructions have been prepared by examination teams for use by SQA appointed markers when marking external course assessments.

The information in this document may be reproduced in support of SQA qualifications only on a non-commercial basis. If it is reproduced, SQA must be clearly acknowledged as the source. If it is to be reproduced for any other purpose, written permission must be obtained from permissions@sqa.org.uk.

Marking instructions

General marking principles

Always apply these general principles. Use them in conjunction with the detailed marking instructions, which identify the key features required in candidates' responses.

- a Always use positive marking. This means candidates accumulate marks for the demonstration of relevant skills, knowledge and understanding; marks are not deducted for errors or omissions.
- b If a candidate response does not seem to be covered by either the principles or detailed marking instructions, and you are uncertain how to assess it, you must seek guidance from your team leader.

Detailed marking instructions

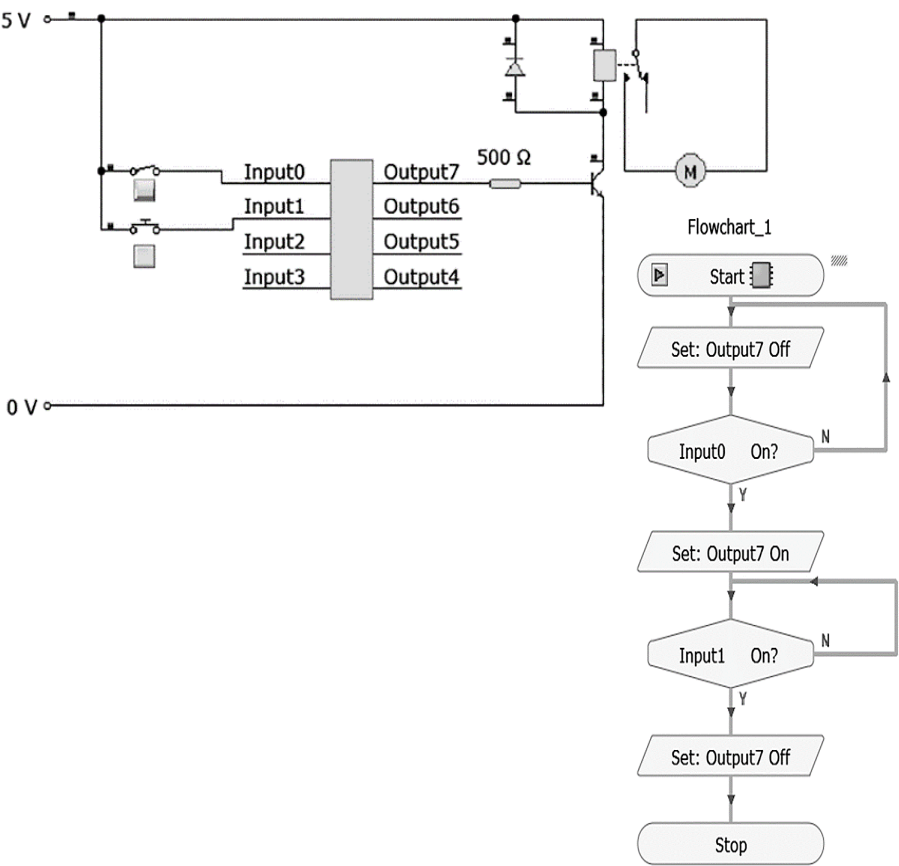
| Task | Expected answer(s) | Max mark | Additional guidance |
|------------|--|----------|--|
| <p>1 a</p> |  <p>The circuit diagram shows a 5V power supply connected to a microcontroller. Input0 is connected to a push-button through a 500Ω resistor. Input1 is connected to another push-button. Output7 is connected to a motor through a 500Ω resistor and a transistor. The flowchart, titled 'Flowchart_1', starts with a 'Start' terminal, followed by 'Set: Output7 Off'. A decision diamond asks 'Input0 On?'. If 'N' (No), it loops back to 'Set: Output7 Off'. If 'Y' (Yes), it goes to 'Set: Output7 On'. Another decision diamond asks 'Input1 On?'. If 'N', it loops back to 'Set: Output7 On'. If 'Y', it goes to 'Set: Output7 Off' and then to a 'Stop' terminal.</p> | <p>5</p> | <p>Electronic circuit:</p> <ul style="list-style-type: none"> ◆ all correct components and values selected as given (1 mark) ◆ correct wiring, microcontroller pin numbers and connections and component orientations. (1 mark) <p>If pin numbers are not visible on microcontroller then refer to flowchart.</p> <p>Flowchart:</p> <ul style="list-style-type: none"> ◆ correct symbols (to the software) with feedback loops and connections as given (1 mark) ◆ all correct pin numbers as given in circuit, pin states and decisions. (1 mark) <p>Integration of flowchart and electronic circuit. (1 mark)</p> <p>Allow use of alternative microcontrollers other than 8-pin.</p> <p>If constructed allow use of alternative pin numbers appropriate to hardware used.</p> |

| Task | | Expected answer(s) | | | | Max mark | Additional guidance |
|------|---|--|---|--|----------------------------|----------|---|
| 1 | b | Planned test | Expected result | Initial test result | Amended test result | 5 | <p>Must be descriptive responses. Not 'yes', 'no' or 'it worked' on its own.</p> <p>Award a maximum of 3 marks for initial test results from each test.</p> <p>Award a maximum of 2 marks for amended test results.</p> <p>Take account of simulation or construction evidence from task 1a and 1c and allow FTE.</p> <p>FTEs should also be applied within each row.</p> <p>Test 1 initial result: relay activates and motor does not turn on. Both the relay and motor must be referred to. (1 mark)</p> <p>Test 1 amended result: motor turns on. (1 mark)</p> <p>Test 2 initial result: motor turns on and then off. Both the motor turning on and off must be referred to. (1 mark)</p> <p>Test 2 amended result: no change in results. (1 mark)</p> <p>Test 3 initial result: motor turns on but does not stop. Both the motor turning on and not stopping must be referred to. (1 mark)</p> <p>Test 3 amended result: motor stops (1 mark)</p> |
| | | Test 1 Turn on the master switch. | The relay should activate and the motor should start turning. | The relay activated and the motor did not turn. | The motor turned on. | | |
| | | Test 2 Turn on the master switch and then turn on the position sensor. | The motor should start turning then slow down and stop. | The motor turned on and then the motor turned off. | No change in results. | | |
| | | Test 3 Turn on the master switch and then turn off the master switch. | The motor should start turning then slow down and stop. | The motor turned on but did not stop. | The motor stopped. | | |

| Task | Expected answer(s) | Max mark | Additional guidance |
|------|--------------------|----------|---|
| 1 c | | 2 | <p>6V power supply / battery to motor circuit. (1 mark)</p> <p>Accept any amendment that allows the circuit to correctly meet specification point i.</p> <p>Input1 decision 'no' should loop back to position shown. (1 mark)</p> <p>Accept any amendment that allows the flowchart to correctly meet specification point iii.</p> <p>Marks can be given for correct amendments previously made in task 1a if no discrete evidence is submitted for 1c.</p> |

| Task | | Expected answer(s) | Max mark | Additional guidance |
|------|---|---|----------|---|
| 1 | d | <pre> main: label0: low 7 label1: if Input0 = 1 then label2 goto label0 label2: high 7 if Input1 = 1 then label3 goto label1 label3: low 7 end </pre> | 1 | <p>Correct code and pin numbers to fully match the final flowchart. (1 mark)</p> <p>Accept manually written or automatically generated.</p> <p>Any high level language is acceptable.</p> |

| Task | | Expected answer(s) | Max mark | Additional guidance |
|------|---|--|----------|--|
| 1 | e | <p>i Yes. When the master switch is pressed the motor turns on.</p> <p>ii Yes. When I activated the position sensor the motor turned off.</p> <p>iii Yes. When the master switch is released / pressed again the motor turns off.</p> <p>Improvement:</p> <ul style="list-style-type: none"> • slow the motor down faster as the stage takes too long to stop • use a more powerful motor to allow a heavier stage • add emergency stops for the stage revolving for safety • use a higher supply voltage to turn the stage motor faster. | 4 | <p>State whether specification point i was met with description referring to master switch and motor turning on. (1 mark)</p> <p>State whether specification point ii was met with description referring to position sensor and motor turning off. (1 mark)</p> <p>State whether specification point iii was met with description referring to master switch and motor turning off. (1 mark)</p> <p>Description of improvement to circuit or flowchart within the real concert venue. (1 mark)</p> <p>Apply FTE from task 1c.</p> |

| Task | | Expected answer(s) | Max mark | Additional guidance |
|------|---|---|----------|---|
| 2 | a | <p>The diagram shows a compound gear train. It consists of four gears. The first gear on the left is labeled 'input' and has 8 teeth. It meshes with a second gear that also has 8 teeth. These two gears are mounted on the same shaft. This shaft also carries a third gear with 48 teeth. The 48-tooth gear meshes with a fourth gear on the right, which is labeled 'output' and has 60 teeth. The 48-tooth gear and the 60-tooth gear are mounted on the same shaft. A dashed line indicates the mesh between the 48-tooth gear and the 60-tooth gear.</p> | 2 | <p>Compound gear train. (1 mark)</p> <p>Only accept use of worm and worm wheel as part of compound gear train.</p> <p>All gear sizes shown plus labelling input or implied (for example, through inclusion of motor or calculations or output labelled) that will give a speed reduction of at least a factor of 40. (1 mark)</p> <p>Award only 1 mark if simple gear train shown with a speed reduction of at least a factor of 40.</p> <p>If simulated (0 marks).</p> |

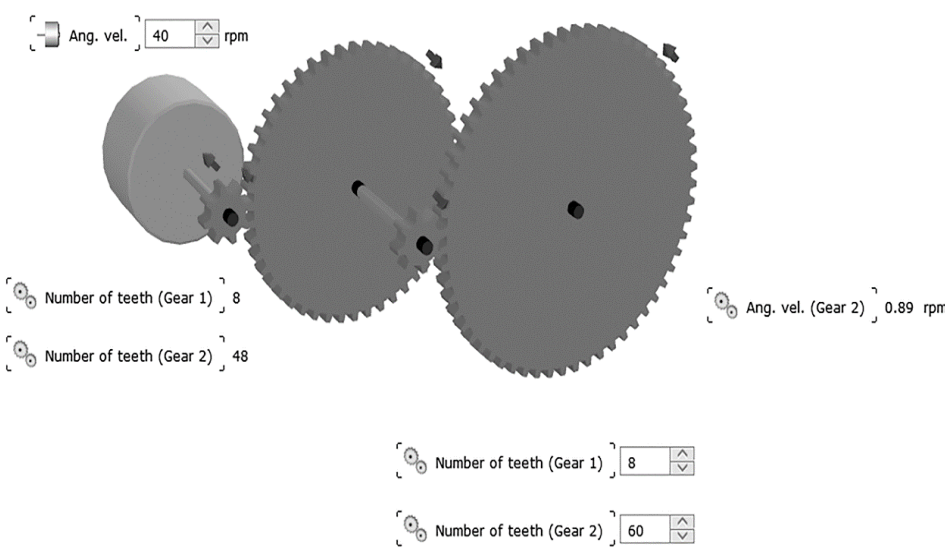
| Task | Expected answer(s) | Max mark | Additional guidance |
|------|---|----------|---|
| 2 b |  <p>Ang. vel. 40 rpm</p> <p>Number of teeth (Gear 1) 8</p> <p>Number of teeth (Gear 2) 48</p> <p>Ang. vel. (Gear 2) 0.89 rpm</p> <p>Number of teeth (Gear 1) 8</p> <p>Number of teeth (Gear 2) 60</p> | 2 | <p>The same type of gear train from 2a simulated or constructed. (1 mark)</p> <p>All gear sizes shown, including input component, to match the design in task 2a or evidence of velocity ratio (for example, graph) that proves teeth numbers. (1 mark)</p> |

| Task | | Expected answer(s) | | | | Max mark | Additional guidance | | | | | | | | | |
|--|-------------|--|-------------------------|-----------------------|--------------|--|-----------------------|--|----|------|-------------------------|--------|--|--|--|--|
| 2 | c | <table border="1"> <thead> <tr> <th>Planned test</th> <th>Input speed</th> <th>Output speed</th> <th>Required velocity ratio</th> <th>Actual velocity ratio</th> </tr> </thead> <tbody> <tr> <td>Measure the input speed and output speed of the gear system and calculate the actual velocity ratio.</td> <td>40</td> <td>0.89</td> <td>At least 40 (40 : 1)</td> <td>45 : 1</td> </tr> </tbody> </table> | Planned test | Input speed | Output speed | Required velocity ratio | Actual velocity ratio | Measure the input speed and output speed of the gear system and calculate the actual velocity ratio. | 40 | 0.89 | At least 40 (40 : 1) | 45 : 1 | | | | <p>2</p> <p>Input/output speeds: Complete table with correct output speed for teeth numbers given in 2b. (1 mark)</p> <p>If no teeth numbers indicated on task 2b refer to 2a.</p> <p>No evidence of simulation or construction in task 2b. (0 mark)</p> <p>Units not required. Accept number of turns.</p> <p>Velocity ratio: Correct value/ratio for given input and output speeds. (1 mark)</p> <p>If no input and output speeds have been entered VR can be derived from 2b or 2a.</p> |
| Planned test | Input speed | Output speed | Required velocity ratio | Actual velocity ratio | | | | | | | | | | | | |
| Measure the input speed and output speed of the gear system and calculate the actual velocity ratio. | 40 | 0.89 | At least 40 (40 : 1) | 45 : 1 | | | | | | | | | | | | |
| 2 | d | <p>i Yes. The output speed was 45 times slower than the input speed which is more than a factor of 40.</p> <p>ii Yes. A compound gear train allows it to fit into a compact space as required.</p> | | | | <p>2</p> <p>State whether specification point i was met with description referring to (output) speed and speed reduction equal to or greater than 40 (comparison). (1 mark)</p> <p>State whether specification point ii was met with description referring to compound arrangement / limited number of gears / size of gears and small space / under stage. (1 mark)</p> <p>Evaluation should be based on 2c, or in its absence 2b, or in its absence design in 2a.</p> | | | | | | | | | | |

| Task | | Expected answer(s) | | Max mark | Additional guidance | |
|---|--|--------------------|--|----------|--|--|
| 3 | a | | | 4 | <p>Test referring to safety guard / plunger and up button. (1 mark)</p> <p>Result referring to piston staying instroke or stage down. (1 mark)</p> <p>Do not accept “nothing happens”.</p> <p>Test referring to down button / button 1 / button 2 pressed. (1 mark)</p> <p>Accept both buttons.</p> <p>Result referring to piston instroke or stage down. (1 mark)</p> <p>Responses must be descriptive.</p> | |
| | | Spec. point | Planned test | | | Expected result |
| | | i | Activate the safety guard and push the up button at same time. | | | The piston should outstroke and the stage will move up. |
| | | | When the stage is down, push the up button without the safety guard being activated. | | | The piston should not outstroke / the stage does not move. |
| | | ii | Activate down button 1 / down button 2 / either down button. | | | The piston should instroke and the stage will move down. |
| When the stage is up, activate down button 2 on ground level. | The piston should instroke / the stage will move down. | | | | | |

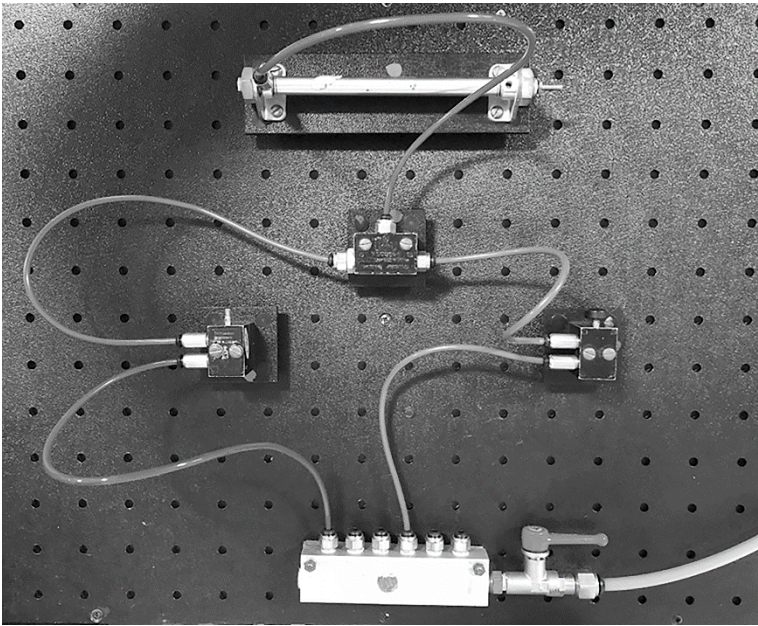
| Task | | Expected answer(s) | Max mark | Additional guidance |
|------|---|---|----------|--|
| 3 | b | <p>Example 1 Slow down the speed of the piston.</p> <p>This would make the platform safer for the people standing on it.</p> <p>Uni-directional restrictor.</p> <p>Example 2 Add a safety guard for when the stage is going down.</p> <p>The stage will not move down when people are standing underneath it and harm them.</p> <p>Plunger 3/2 spring return valve.</p> | 3 | <p>Description of suitable improvement to the pneumatic circuit. (1 mark)</p> <p>Justification for improvement in terms of safety (FTE). (1 mark)</p> <p>Not “safer” on its own. Must refer to context of real concert venue.</p> <p>Suitable, correctly named, pneumatic component(s). (1 mark)</p> |
| 3 | c |  | 3 | <p>Piping of 3/2 valve A to shuttle including main air. (1 mark)</p> <p>Piping of 3/2 valve B to shuttle including main air. (1 mark)</p> <p>Piping of shuttle valve to single acting cylinder. (1 mark)</p> <p>Accept use of any 3/2 valve actuator.</p> |

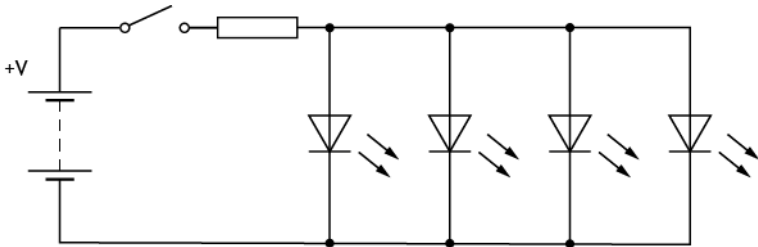
| Task | Expected answer(s) | Max mark | Additional guidance |
|------|---|----------|---|
| 4 |  <p>The diagram shows a circuit with a battery on the left labeled '+V'. A switch is connected in series with the positive terminal. Following the switch is a resistor. The circuit then branches into four parallel paths, each containing an LED. All LEDs are oriented with their cathodes towards the positive terminal and their anodes towards the negative terminal. The circuit returns to the negative terminal of the battery.</p> | 4 | <p>Four LEDs drawn with correct symbol and orientation. (1 mark)</p> <p>All LEDs drawn in parallel (FTE). (1 mark)</p> <p>Protective resistor(s) with correct symbol to protect all LEDs. (1 mark)</p> <p>Accept single protective resistor before or after all LEDs or resistors on each LED branch.</p> <p>One SPST switch with correct symbol drawn in suitable position. (1 mark)</p> <p>Accept simulation.</p> <p>Ignore any values.</p> <p>If any additional components / wires affect the operation of LEDs then max. 3 marks.</p> |

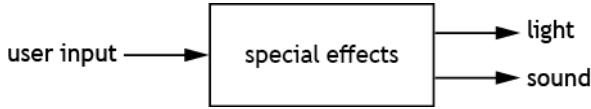
| Task | | | Expected answer(s) | Max mark | Additional guidance |
|------|---|---|--|----------|---|
| 5 | a | i |  <pre> graph LR A[user input] --> B[special effects] B --> C[light] B --> D[sound] </pre> | 2 | <p>User input action / pressure identified and in the correct position with arrow. (1 mark)</p> <p>Light and sound /noise outputs identified and in the correct position with arrow(s). (1 mark)</p> <p>Award only 1 mark if all correct inputs and outputs but without arrows.</p> <p>Ignore boxes, extra boxes or words.</p> |

| Task | | | Expected answer(s) | Max mark | Additional guidance |
|------|---|----|--------------------|----------|--|
| 5 | a | ii | | 5 | <p>(Master) switch connected to microcontroller in correct position. (1 mark)</p> <p>Do not accept switch as feedback sensor.</p> <p>One driver per output device individually connected to microcontroller. (1 mark)</p> <p>Lamp connected in output position. (1 mark)</p> <p>Siren connected in output position. (1 mark)</p> <p>System boundary around sub-systems only and boxes around each sub-system. (1 mark)</p> <p>Do not accept 'light', 'bulb' or 'LED' instead of 'lamp'.</p> <p>Do not accept 'buzzer' instead of 'siren'.</p> <p>Do not accept an action (e.g. lamp on).</p> <p>Ignore extra sub-systems.</p> <p>If no arrows shown, assume left to right.</p> |

| Task | | Expected answer(s) | Max mark | Additional guidance |
|------|---|---|----------|--|
| 5 | b | <pre> graph TD Start([start]) --> Pin0{is pin 0 on?} Pin0 -- N --> Start Pin0 -- Y --> Pin7High[/pin 7 high/] Pin7High --> Wait05[Wait 0.5 seconds] Wait05 --> Pin7Low[/pin 7 low/] Pin7Low --> Wait05_2[Wait 0.5 seconds] Wait05_2 --> Done10{Has been done 10 times?} Done10 -- N --> Pin7High Done10 -- Y --> Pin6High[/pin 6 high/] Pin6High --> Wait5[Wait 5 seconds] Wait5 --> Pin6Low[/Pin 6 low/] Pin6Low --> End([end]) </pre> | 4 | <p>Pin 0 / master switch decision with Y or N and loop. (1 mark)</p> <p>Pin 7 / lamp high and low and both 0.5 s delays. (1 mark)</p> <p>x 10 decision and correct entry. (1 mark)</p> <p>Pin 6 / siren high and low and 5 s time delay and sequence ending. (1 mark)</p> <p>Accept pin 7 / lamp high and low and time 0.5 s delays repeated 10 times.</p> <p>Can be manually drawn or produced on simulation software.</p> <p>Flowchart may refer to pin numbers from task 5b or could be descriptive.</p> <p>Ignore additional stages.</p> |

[END OF MARKING INSTRUCTIONS]