



National 5 Engineering Science Assignment

Assessment task: concert venue

This document provides information for teachers and lecturers about the coursework component of this course in terms of the skills, knowledge and understanding that are assessed. It **must** be read in conjunction with the course specification.

Valid for session 2018-19 only.

The information in this publication may be reproduced in support of SQA qualifications only on a non-commercial basis. If it is reproduced, SQA must be clearly acknowledged as the source. If it is to be reproduced for any other purpose, written permission must be obtained from permissions@sqa.org.uk.

Where this publication includes material for which SQA does not own the copyright, this material must only be reproduced on a non-commercial basis for the purposes of instruction in an educational establishment. If it is to be reproduced for any other purpose, it is the user's responsibility to obtain the necessary copyright clearance from the copyright owner. The acknowledgements page lists the owners of copyright items that are not owned by SQA.

This edition: January 2019 (version 1.0)

© Scottish Qualifications Authority 2019

Contents

Introduction	1
Instructions for teachers and lecturers	2
Instructions for candidates	6
Worksheets	22

Introduction

This document contains instructions for teachers and lecturers, and instructions for candidates for the National 5 Engineering Science assignment. It must be read in conjunction with the course specification.

This assignment has 50 marks out of a total of 160 marks available for the course assessment.

This is one of two course assessment components. The other component is a question paper.

Instructions for teachers and lecturers

This task is valid for session 2018-19 only. Once complete, you must send the assignment responses to SQA to be marked.

You must conduct the assignment under a high degree of supervision and control.

This means:

- ◆ candidates must be within your direct sight
- ◆ candidates must not interact with each other
- ◆ candidates must not have access to e-mail, the internet and mobile phones
- ◆ candidates must complete their work independently – no group work is permitted
- ◆ classroom display materials, which might provide assistance, must be removed or covered up
- ◆ there must be no interruption for learning and teaching
- ◆ candidates must be in a classroom environment

Time

Candidates have 8 hours to complete the assignment, starting at an appropriate point in the course after all course content has been delivered. Once candidates begin their assignment, they must continue in each subsequent class period until the permitted time allocation has been used up.

You have a responsibility to manage candidates' work, distributing it at the beginning and collecting it at the end of each period, and storing it securely in between. This activity does not count towards the total time permitted for candidates to complete the assignment.

Resources

This is a closed-book assessment. Candidates must not have access to learning and teaching materials, the internet, notes, exemplar materials, resources on classroom walls or anything similar.

A data booklet containing relevant data and formulae is available on the National 5 Engineering Science subject page on SQA's website. This can be used for the assignment.

Each assignment assessment task includes instructions and details of any equipment or materials required for the assignment. Candidates can also use normal classroom equipment, software and hardware (such as drawing instruments, pneumatics, mechanisms and electronics kit, simulation software, and PCs to run the software) to complete the tasks.

There may be instances where restriction of internet and/or network use is not practical or feasible (for example, a local authority-managed network with specific limitations, software that is web-based, or something similar), however, it remains your professional responsibility to make every effort to meet the assessment conditions.

Reasonable assistance

Candidates must progress through each stage of the assignment without your intervention or guidance, having acquired the skills earlier in the course.

Once candidates complete the assignment, you must not return it to them for further work. You must not provide feedback to candidates or offer your opinion on the perceived quality or completeness of the assignment response at any stage.

You can provide reasonable assistance to support candidates with the following aspects of their assignment:

- ◆ printing, collating and labelling their evidence to ensure it is in the format specified by SQA
- ◆ ensuring candidates have all the materials and equipment required to complete the assignment
- ◆ understanding the information outlined in these instructions

Evidence

All candidate evidence (whether created manually or electronically) must be submitted to SQA in paper-based format.

Each task details what evidence is required and how many pages are expected. This is a guide to ensure that candidates do not produce too much or spend too long on a single task.

Candidates must submit single-sided A4 pages. The pages must not have anything fixed to them. Any screenshots, simulation printouts and/or images must be clear and easy to read.

Alteration or adaptation

You must not alter, adapt or modify the assignment in any way. This includes moving the content of the assignment into a different format or workbook. All candidates must undertake the assignment exactly as it is provided by SQA.

Submission

Each piece of work must be labelled with the task number, for example, task 2a, and the back of each page must be clearly labelled with the candidate's details.

Photographs must show the candidate's name next to the piece of work.

Only pages containing candidate evidence are to be submitted and evidence must be submitted in task order.

Volume

There is no word or page count.

Specific instructions for teachers and lecturers: 2018-19 assignment

You must follow these specific instructions. You must ensure that candidates are aware of the assessment conditions and know what they should do for each task.

This assignment has five mandatory tasks. Candidates can complete the tasks in the order presented or in an order that helps manage classroom equipment.

Each task has a notional time allocated to it – this provides an indication of how long candidates should spend on the task.

All tasks must be completed on A4 single-sided paper or the worksheets provided, with the task number clearly labelled.

Any evidence printed (screenshots or images) **must be clear and easy to read.**

Task 1 (17 marks)

Notional time: 2 hours and 30 minutes

- ◆ task 1: completed on up to five single-sided A4 pages
- ◆ tasks 1b and 1e: worksheets are provided for these tasks

Task 2 (8 marks)

Notional time: 1 hour and 30 minutes

- ◆ task 2: completed on up to four single-sided A4 pages
- ◆ task 2a: **candidates must not use simulation software for this task**
- ◆ tasks 2c and 2d: worksheets are provided for these tasks

Task 3 (10 marks)

Notional time: 2 hours

- ◆ task 3: completed on up to three single-sided A4 pages
- ◆ tasks 3a and 3b: worksheets are provided for these tasks

Task 4 (4 marks)

Notional time: 30 minutes

- ◆ task 4: completed on one single-sided A4 page
- ◆ task 4: a worksheet is provided for this task

Task 5 (11 marks)

Notional time: 1 hour and 30 minutes

- ◆ task 5: completed on up to three single-sided A4 pages
- ◆ tasks 5a(i), 5a(ii) and 5b: worksheets are provided for these tasks

Note: electronically-generated evidence (for example simulations and coding) is included in the expected number of pages for each task. This must be printed off and compiled for uplift by SQA.

Instructions for candidates

This assessment applies to the assignment for National 5 Engineering Science.

The assignment has 50 marks out of a total of 160 marks available for the course assessment.

It assesses the following skills, knowledge and understanding:

- ◆ demonstrating engineering science skills and creativity
- ◆ analysing engineering problems
- ◆ designing and building/simulating solutions to engineering problems
- ◆ testing and evaluating solutions to engineering problems

This is a closed-book assessment. Your teacher or lecturer will let you know how the assessment will be carried out and any required conditions for doing it.

In this assessment, you have to:

- ◆ analyse a problem
- ◆ design a solution to the problem
- ◆ simulate or construct your solution
- ◆ test your solution
- ◆ evaluate your work

You have 8 hours to complete the assignment. The time to set up and clear away any equipment you will need, and for any printing that is necessary, does not count towards the 8 hours.

You should complete all of the tasks in the order presented, unless otherwise instructed.

The assignment has five tasks, with marks allocated as follows:

Task 1 – 17 marks: building, testing, designing (electronics and programmable control), and evaluating a solution for the revolving stage
(building = 5 marks, testing = 7 marks, designing = 1 mark, evaluating = 4 marks)

Task 2 – 8 marks: designing, building, testing, and evaluating (mechanisms) for the speed control of the revolving stage
(designing = 2 marks, building = 2 marks, testing = 2 marks, evaluating = 2 marks)

Task 3 – 10 marks: testing, evaluating (pneumatics), and building a solution for the stage lifting system
(testing = 4 marks, evaluating = 3 marks, building = 3 marks)

Task 4 – 4 marks: designing a solution (electronics) for the emergency exit lighting
(designing = 4 marks)

Task 5 – 11 marks: analysing, and designing a solution (programmable control) for the special effects
(analysing = 7 marks, designing = 4 marks)

For each task, you are provided with an engineering science problem or situation.

Submitting your work

Your teacher or lecturer will let you know the approximate amount of time to spend on each task, along with an indication of the number of single-sided A4 pages of evidence that you should produce.

You must label each piece of your work with the task number (for example, task 2a), and on the back of each page include your:

- ◆ name
- ◆ date of birth
- ◆ Scottish Candidate Number (SCN)
- ◆ centre name
- ◆ centre number

Candidate data sheets – concert venue

You can use these data sheets and SQA's National 5 data booklet when completing this assignment. No other resource material is permitted.

Electronic components

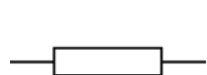

resistor

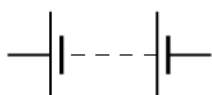

battery

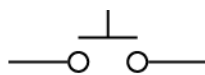

push switch

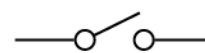

SPST switch

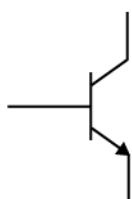

NPN
transistor



diode

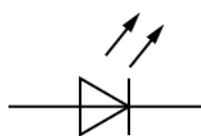

LED

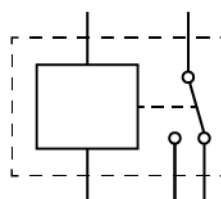

SPDT relay



motor

Pneumatic components

Actuators

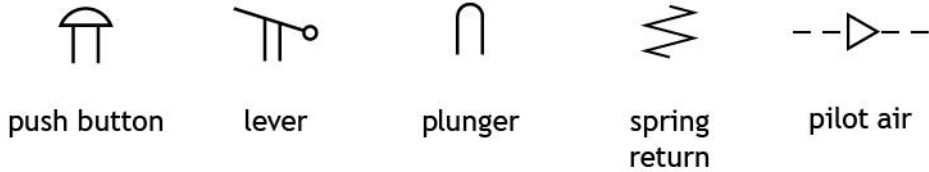

Valves

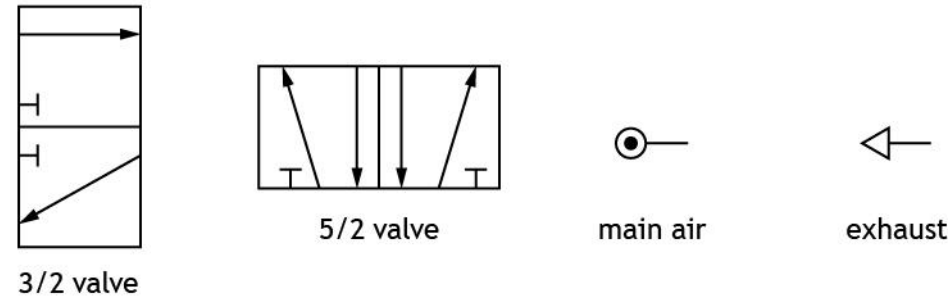

Components and cylinders

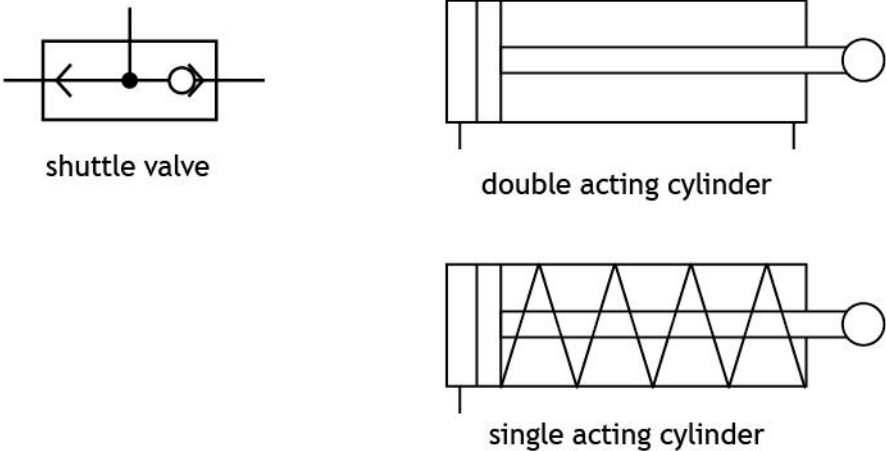

Concert venue

A team of engineers is involved in several tasks during the planning of a new concert venue.

These tasks include developing proposals for the following sub-systems:

Task 1 – revolving stage – control sub-system

Task 2 – revolving stage – drive mechanism sub-system

Task 3 – stage lift sub-system

Task 4 – emergency exit lighting sub-system

Task 5 – special effects sub-system



Task 1 – revolving stage – control sub-system

A stage is required to revolve during a concert.

An electronic engineer has designed the flowchart and circuit shown below as a possible solution. The pin numbers used to connect the circuit to the microcontroller are shown in the table below.

- 1a Simulate or construct the flowchart sequence and electronic circuit integrated together as shown.

A microcontroller of an alternative size may be used but the pin numbers must match the connections given.

You must present your evidence on A4 single-sided pages with the task number clearly labelled. Screenshots or images must be clear and easy to read.

(5 marks)

Input connection	Pin	Output connection
	7	motor
position sensor	1	
master switch	0	

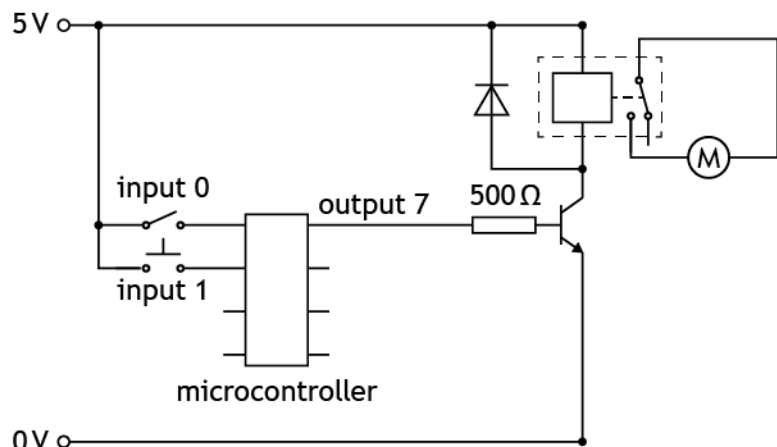
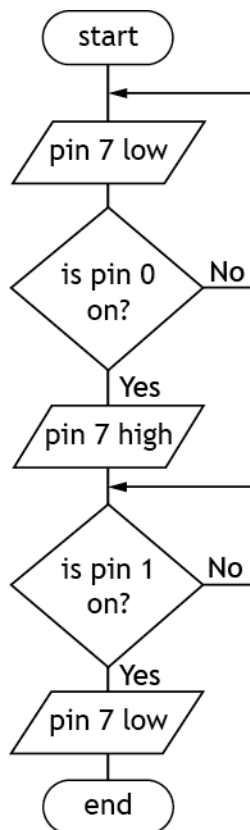

Task 1 – revolving stage – control sub-system (continued)

The revolving stage is to be operated by a microcontroller, using the following specification.

- i When the operator turns on a master switch, a 6 V circuit activated by an SPDT relay will turn on a motor.
- ii When a position sensor is activated the motor should slow down and stop.
- iii If the master switch is turned off before the position sensor is activated the motor should slow down and stop.

Errors were found with the design during testing.

- 1b Complete the testing table on **worksheet 1b** by carrying out each planned test given and describing each initial test result.

You should **make amendments to the flowchart and/or circuit as necessary to meet the specification and complete each test again**. Describe the result of any amended flowchart and/or circuit test before moving on to the next test.

You must present your evidence of the testing table on A4 single-sided pages, with the task number clearly labelled.

(5 marks)

- 1c Your final amended flowchart and electronic circuit should now **meet the specification** given at the start of **task 1b**.

After completing **task 1b**, you must present the evidence of your final **amended flowchart and electronic circuit integrated together**, on A4 single-sided pages, with the task number clearly labelled. Screenshots or images must be **clear and easy to read**.

(2 marks)

- 1d Produce high-level microcontroller code to fully match your final amended flowchart from **task 1c**.

You must present your evidence on A4 single-sided pages, with the task number clearly labelled. Screenshots or images **must be clear and easy to read**.

(1 mark)

Task 1 – revolving stage – control sub-system (continued)

1e Evaluate the performance of your final amended solution from **task 1c** against the specification given in **task 1b** by completing **worksheet 1e**. You must:

- ◆ state if each specification point was met
- ◆ describe the performance of your amended solution to meet **each of the three specification points**
- ◆ describe one improvement to your final amended solution that would make it suitable for use in a real concert venue.

You must present your evidence on A4 single-sided pages, with the task number clearly labelled.

(4 marks)

Task 2 – revolving stage – drive mechanism sub-system

The speed of the motor used to revolve the stage needs to be reduced. A compound gear train is required that will meet the following specification.

- i Reduce the output speed from the motor by at least a factor of 40.
- ii Fit into a compact space underneath the stage.

2a Design a compound gear train (based on gear sizes available to you) that will meet the specification. You must label the input gear and include all gear sizes.

You must present your evidence on A4 single-sided pages, with the task number clearly labelled. Your evidence **must be clear and easy to read**.

You must not use simulation software to complete task 2a.

(2 marks)

2b Simulate or construct your design from **task 2a**. You must include an input component to allow for testing and **label all gear sizes**.

You must present your evidence on A4 single-sided pages, with the task number clearly labelled. Screenshots or images **must be clear and easy to read**.

(2 marks)

Task 2 – revolving stage – drive mechanism sub-system (continued)

2c Complete the testing table on **worksheet 2c** by:

- ◆ entering the results for the input and output speeds of the gear system that you observed during simulating or constructing
- ◆ calculating the actual velocity ratio using your recorded values for the input and output speeds.

You must present your evidence on A4 single-sided pages, with the task number clearly labelled.

(2 marks)

2d Evaluate the performance of your solution from **tasks 2b and 2c** against the given specification by completing the table on **worksheet 2d**. You should:

- ◆ state if each specification point was met
- ◆ describe the performance of your solution against both specification points.

You must present your evidence on A4 single-sided pages, with the task number clearly labelled.

(2 marks)

Task 3 – stage lift sub-system

A pneumatic circuit is to be used to lift part of the stage and must meet the following specification:

- i The stage will only move up when a safety guard is in place and the up button is pressed.
- ii The stage will move down when either down button 1 or down button 2 is pressed.

A mechanical engineer designed the pneumatic circuit shown below as a possible solution.

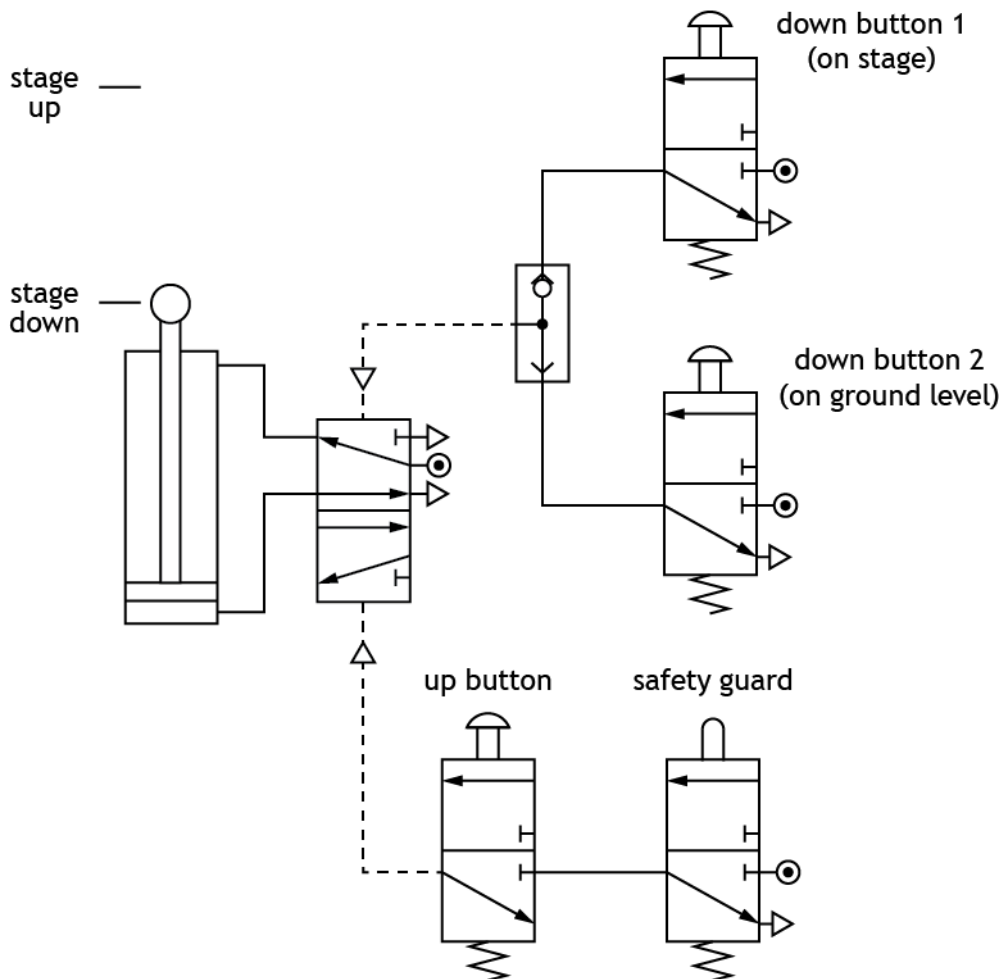

Task 3 – stage lift sub-system (continued)

3a Complete the test plan on **worksheet 3a** for the stage lifting system by describing:

- ◆ the two tests that would produce the expected results given
- ◆ the two results that would be expected from each of the tests given.

You must present your evidence on A4 single-sided pages, with the task number clearly labelled.

(4 marks)

3b Describe and justify one improvement that could be made to make the pneumatic circuit safer for use in a real concert venue on **worksheet 3b**.

You must name any component(s) required for the improvement.

You must present your evidence on A4 single-sided pages, with the task number clearly labelled.

(3 marks)

Task 3 – stage lift sub-system (continued)

3c Part of the stage lift sub-system is to be tested using the pneumatic circuit shown below.

Simulate or construct the pneumatic circuit shown.
Alternative actuators on the 3/2 valves may be used.

You must present your evidence on A4 single-sided pages, with the task number clearly labelled. Screenshots or images **must be clear and easy to read**.

(3 marks)

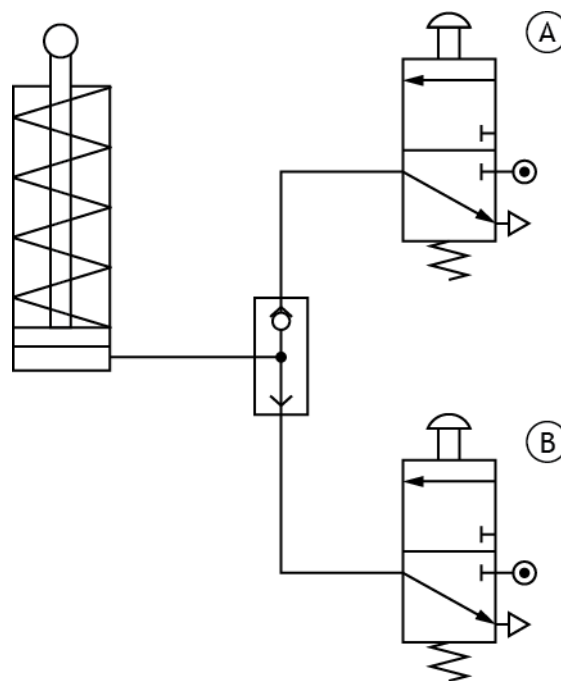

Task 4 – emergency exit lighting sub-system

During a concert, the main lights in the venue will be switched off. To allow people to find their way to an emergency exit, a lighting system is required to meet the following specification.

- i When an SPST switch is pressed four LEDs must turn on.
- ii If any one LED is broken then all other LEDs should remain on.
- iii The LEDs must be protected from a large current.

Complete the circuit diagram shown on **worksheet 4** to meet the above specification. A voltage supply has been given.

You must present your evidence on A4 single-sided pages, with the task number clearly labelled. Screenshots or images **must be clear and easy to read**.

(4 marks)

Task 5 – special effects sub-system

A microcontroller-based circuit operates the special effects in the concert venue. The specification for a pre-concert test sequence is shown below.

- i When a master switch is pressed, a lamp will turn on for 0.5 seconds and then off for 0.5 seconds. This will be repeated 10 times.
- ii After the lamp has turned on and off 10 times, a siren will turn on for 5 seconds and then turn off, ending the sequence.

- 5a (i) Complete the **system diagram** on **worksheet 5a(i)** to meet the specification. You must clearly show all inputs and outputs.

You must present your evidence on A4 single-sided pages, with the task number clearly labelled. Your evidence **must be clear and easy to read**.

(2 marks)

- 5a (ii) Complete the **sub-system diagram** on **worksheet 5a(ii)** to meet the specification. You must clearly show all inputs and outputs, all sub-systems, the system boundary and interactions between sub-systems. **Each output device requires a driver**.

You must present your evidence on A4 single-sided pages, with the task number clearly labelled. Your evidence **must be clear and easy to read**.

(5 marks)

Task 5 – special effects sub-system (continued)

- 5b Complete the flowchart on **worksheet 5b** for the special effects test sequence. You should refer to the specification given at the start of this task, and the pin numbers shown in the table below.

You can find the flowchart symbols in the data booklet.

You must present your evidence on A4 single-sided pages, with the task number clearly labelled. Screenshots or images **must be clear and easy to read**.

(4 marks)

Input connection	Pin	Output connection
	7	lamp
	6	siren
master switch	0	

[END OF ASSIGNMENT]



National 5 Engineering Science Assignment

Assessment task: concert venue

Worksheets

This document provides information for teachers and lecturers about the coursework component of this course in terms of the skills, knowledge and understanding that are assessed. It must be read in conjunction with the course specification.

Valid for session 2018-19 only.

The information in this publication may be reproduced in support of SQA qualifications only on a non-commercial basis. If it is reproduced, SQA must be clearly acknowledged as the source. If it is to be reproduced for any other purpose, written permission must be obtained from permissions@sqa.org.uk.

Where this publication includes material for which SQA does not own the copyright, this material must only be reproduced on a non-commercial basis for the purposes of instruction in an educational establishment. If it is to be reproduced for any other purpose, it is the user's responsibility to obtain the necessary copyright clearance from the copyright owner. The acknowledgements page lists the owners of copyright items that are not owned by SQA.

This edition: January 2019 (version 1.0)

© Scottish Qualifications Authority 2019

Worksheet 1b

Planned test	Expected result	Initial test result	Amended test result
Test 1 Turn on the master switch.	The relay should activate and the motor should start turning.		
Test 2 Turn on the master switch and then after a few seconds turn on the position sensor.	The motor should start turning then slow down and stop.		
Test 3 Turn on the master switch and then turn off the master switch.	The motor should start turning then slow down and stop.		

(5 marks)

Name:	
Date of birth:	
Scottish Candidate Number (SCN):	
Centre name:	
Centre number:	

Worksheet 1e

Specification point	Met? Y or N	Description
i		
ii		
iii		

Improvement	
-------------	--

(4 marks)

Name:	
Date of birth:	
Scottish Candidate Number (SCN):	
Centre name:	
Centre number:	

Worksheet 2c

Planned test	Input speed	Output speed	Required velocity ratio	Actual velocity ratio
Measure the input speed and output speed of the gear system and calculate the actual velocity ratio.			At least 40 (40 : 1)	

(2 marks)

Name:	
Date of birth:	
Scottish Candidate Number (SCN):	
Centre name:	
Centre number:	

Worksheet 2d

Specification point	Met? Y or N	Description
i		
ii		

(2 marks)

Name:	
Date of birth:	
Scottish Candidate Number (SCN):	
Centre name:	
Centre number:	

Worksheet 3a

Specification point	Planned test	Expected result
i		The piston should outstroke and the stage will move up.
	When the stage is down, push the up button without the safety guard being activated.	
ii		The piston should instroke and the stage will move down.
	When the stage is up, activate down button 2 on ground level.	

(4 marks)

Name:	
Date of birth:	
Scottish Candidate Number (SCN):	
Centre name:	
Centre number:	

Worksheet 3b

Improvement	
Justification	
Components required	

(3 marks)

Name:	
Date of birth:	
Scottish Candidate Number (SCN):	
Centre name:	
Centre number:	

Worksheet 4

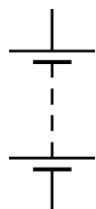

(4 marks)

Name:	
Date of birth:	
Scottish Candidate Number (SCN):	
Centre name:	
Centre number:	

Worksheet 5a(i)

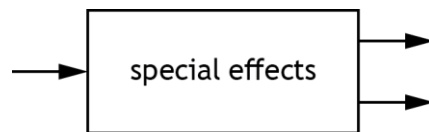

(2 marks)

Name:	
Date of birth:	
Scottish Candidate Number (SCN):	
Centre name:	
Centre number:	

Worksheet 5a(ii)

microcontroller

(5 marks)

Name:	
Date of birth:	
Scottish Candidate Number (SCN):	
Centre name:	
Centre number:	

Worksheet 5b

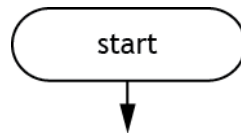

(4 marks)

Name:	
Date of birth:	
Scottish Candidate Number (SCN):	
Centre name:	
Centre number:	

Acknowledgement of copyright
Page 10 Narcis Parfenti/Shutterstock.com

Administrative information

Published: January 2019 (version 1.0)

History of changes

Version	Description of change	Date

Security and confidentiality

This document can be used by practitioners in SQA approved centres for the assessment of National Courses and not for any other purpose.