

FOR OFFICIAL USE



National
Qualifications
2022

Mark

X823/75/01

Engineering Science

WEDNESDAY, 18 MAY

1:00 PM – 2:50 PM



* X 8 2 3 7 5 0 1 *

Fill in these boxes and read what is printed below.

Full name of centre

Town

Forename(s)

Surname

Number of seat

Date of birth

Day

Month

Year

Scottish candidate number

Total marks — 110

SECTION 1 — 20 marks

Attempt ALL questions.

SECTION 2 — 90 marks

Attempt ALL questions.

Show all working and units where appropriate.

You should refer to the National 4/5 Engineering Science Data Booklet which you have been given.

The number of significant figures expressed in a final answer should be equivalent to the least significant data value given in the question. Answers that have two more figures or one less figure than this will be accepted.

Write your answers clearly in the spaces provided in this booklet. Additional space for answers is provided at the end of this booklet. If you use this space you must clearly identify the question number you are attempting.

Use **blue** or **black** ink.

Before leaving the examination room you must give this booklet to the Invigilator; if you do not, you may lose all the marks for this paper.



* X 8 2 3 7 5 0 1 0 1 *

SECTION 1 — 20 marks

Attempt ALL questions

1. A gear train is shown below.

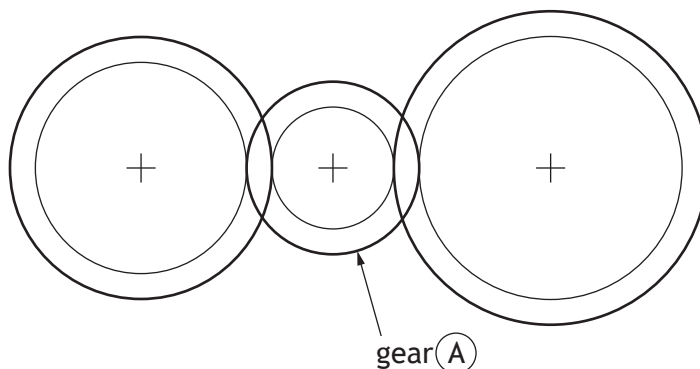

(a) State the type of gear train shown.

1

(b) State the name of gear A.

1

2. An incomplete system diagram for a hair dryer is shown.

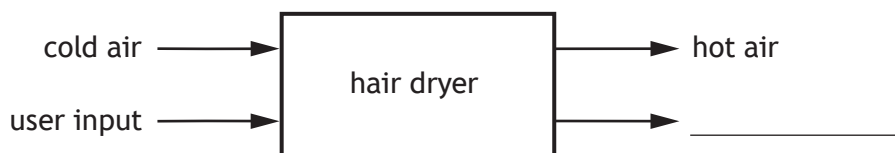

(a) Complete the system diagram above by adding the missing output.

1

(b) State the type of control that has no feedback.

1



3. A force of 2200 N is required to push a workbench across a workshop floor. Calculate the work done when the workbench is pushed a distance of 12 m.

2

4. Transistors are used in many electronic products.

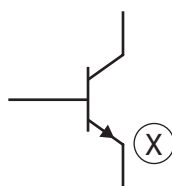

- (a) Describe the **function** of a transistor.

1

- (b) State the name of connection (X) on the transistor symbol above.

1

[Turn over



5. A tensioner is used to tighten the wire on a farm fence.

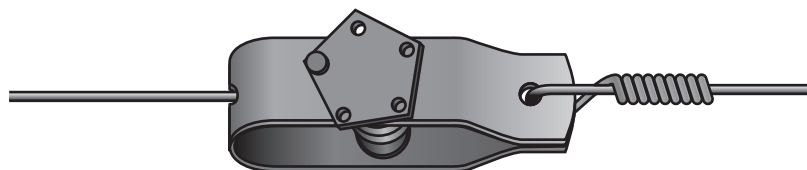

A 25 m length of wire was stretched by 0.012 m when fully tensioned.

(a) Calculate the strain in the wire.

2

The table below shows details of materials that were considered for the wire.

Material	Corrosion resistant	Property
A	no	ductile
B	yes	brittle
C	yes	ductile
D	no	brittle

(b) Select the most suitable material (A–D) from the table for the wire and justify your choice.

2

Choice of material _____

Justification _____



6. An offshore wind farm has wind turbines which are located out at sea. A diagram of the inside of one of the wind turbines is shown.

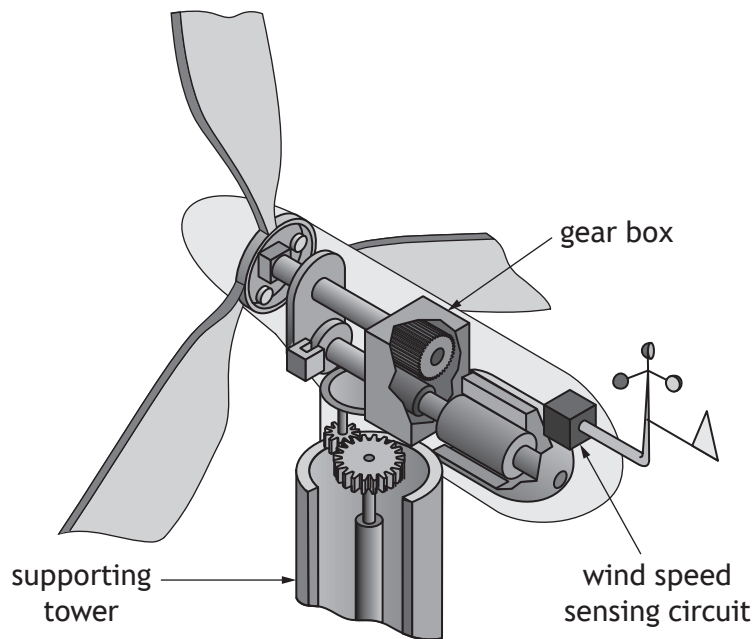

(a) State which branch of engineering would be responsible for the design of the:

(i) wind speed sensing circuit

1

(ii) supporting tower

1

(iii) gear box.

1

(b) Describe one role an **environmental** engineer would have during the **construction** of the offshore wind farm.

1

[Turn over



7. Three forces, in equilibrium, acting on part of a structure are shown below.

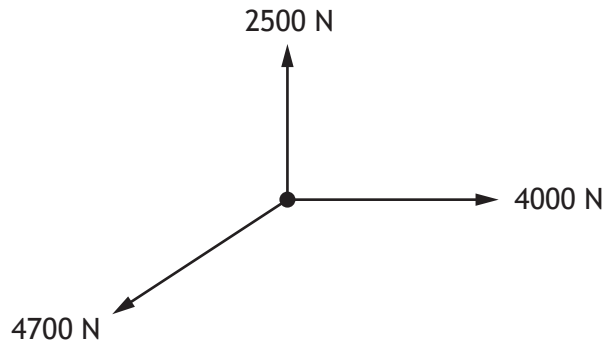

Complete the triangle of forces **scale drawing** below for the given forces.
Forces must include an arrow head to show the direction.

2

scale 10 mm = 500 N

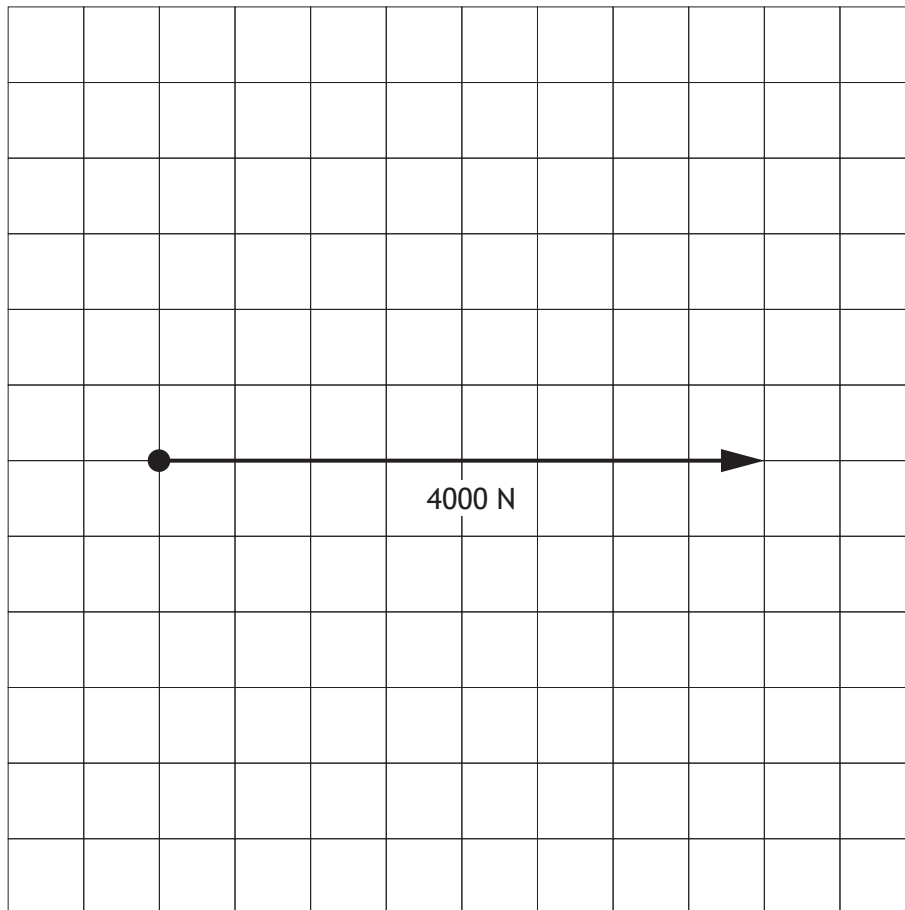

8. A solar farm is shown.



Describe two **environmental** impacts of solar as a source of energy.

2

1 _____

2 _____

[Turn over



SECTION 2 — 90 marks

Attempt ALL questions

9. In a swimming competition, a system is used to automatically measure a competitor's time.



The system is operated by a microcontroller.

The input and output connections to the microcontroller are shown in the table below.

Input connections	Pin	Output connections
	7	buzzer
	6	timer
lane switch	1	
master switch	0	

The system operates using the following sequence.

- A master switch is pressed
- A buzzer then sounds on and then off three times over 1.5 seconds
- The timer then starts
- When a lane switch is pressed the timer stops
- The system will then reset ready to be used again



9. (continued)

- (a) Complete the flowchart for the sequence, with reference to the data booklet and input/output connections.

Include all pin numbers and delay units in your flowchart.

10

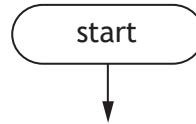

9. (continued)

A program used in a different control system is listed below.

```

line  program
1   main:    let count = 0
2   label_1: switch on 4
3           switch on 5
4           pause 600
5           switch off 4
6           switch off 5
7           pause 600
8           let count = count + 1
9           if count = 20 then label_2
10          goto main
11  label_2: if Input0 is on then label_3
12          goto label_2
13  label_3: switch on 7
14          pause 3000
15          switch off 7
16          goto main

```

(b) Describe the function of **line 16** in the program. 1

Lines 2 to 9 should repeat twenty times before moving on to **line 11**.

During testing an electronic engineer found that this did not happen.

(c) Explain why **lines 2 to 9** did not repeat twenty times before moving on to **line 11**. 2



[Turn over for next question

DO NOT WRITE ON THIS PAGE



* X 8 2 3 7 5 0 1 1 1 *

10. The road gritter shown below is used to spread salt on icy roads.



The warning circuit shown below is used to alert the driver of a low temperature.

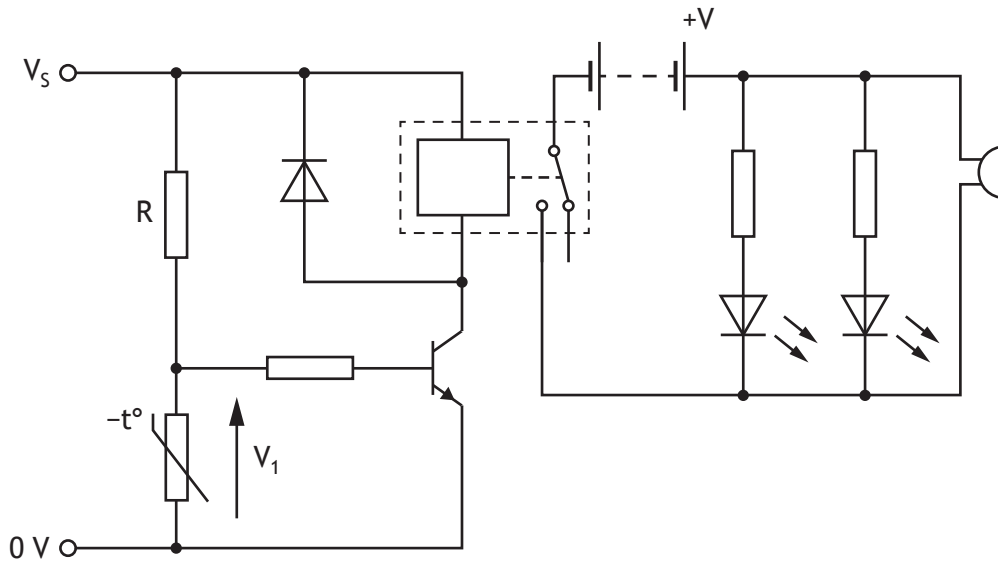

10. (continued)

The input sensing circuit (which is part of the warning circuit) is shown below.

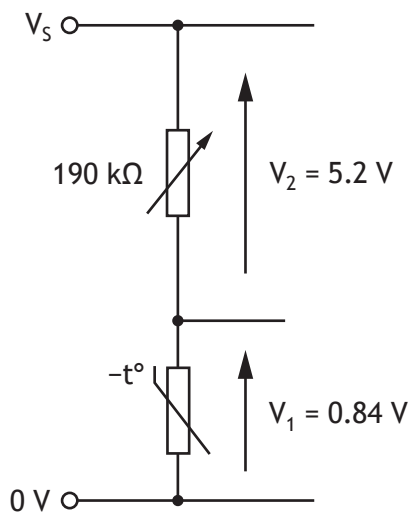

(c) Calculate the resistance of the thermistor.

3

10. (continued)

The operating characteristics of a range of thermistors are shown on the graph below.

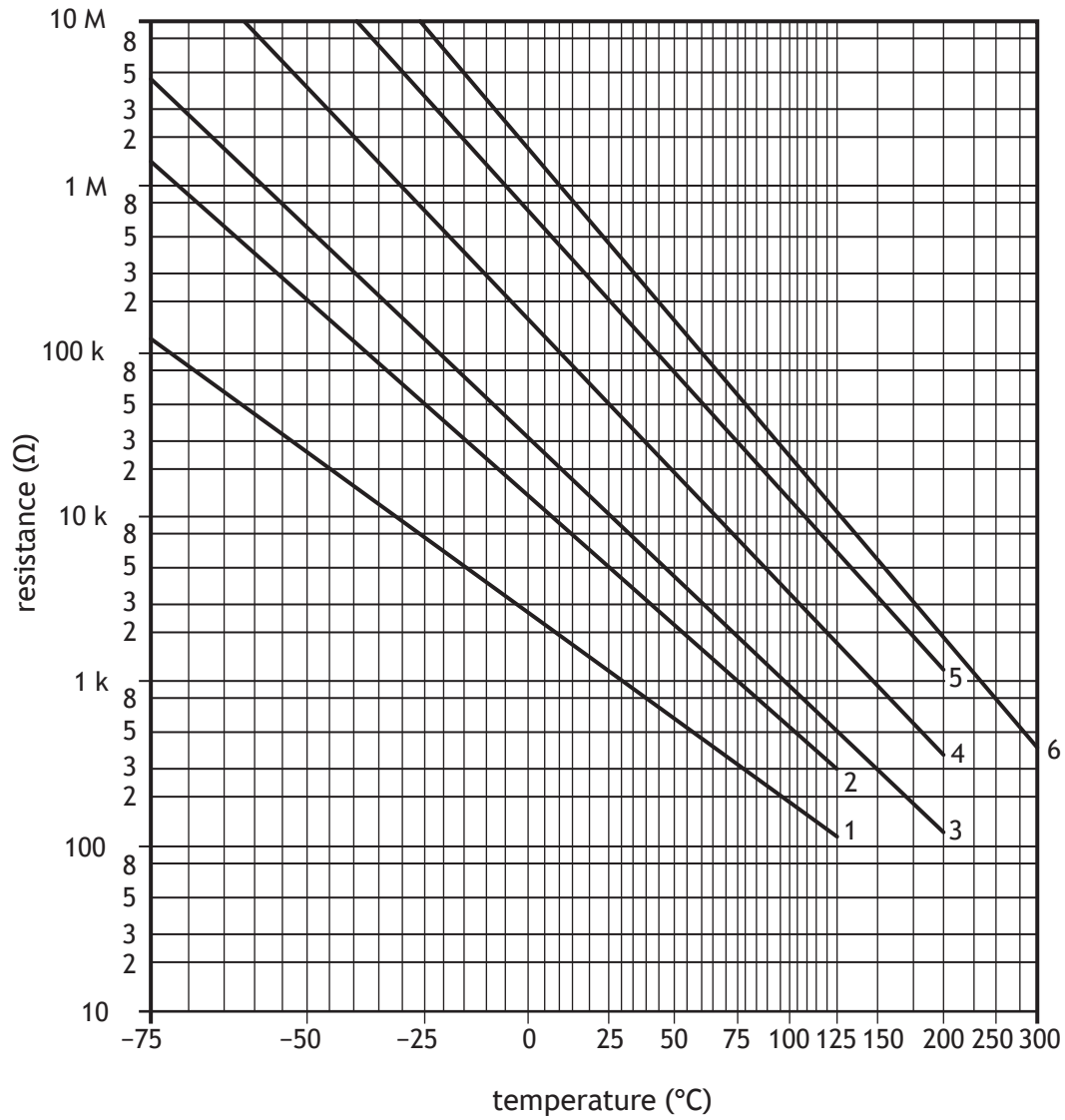

- (d) Determine (with reference to the graph above) the resistance of a **type 3** thermistor when the temperature is 10 °C.

1

[Turn over



10. (continued)

MARKS DO NOT WRITE IN THIS MARGIN

The gear train shown below is used to drive the salt spreading system.

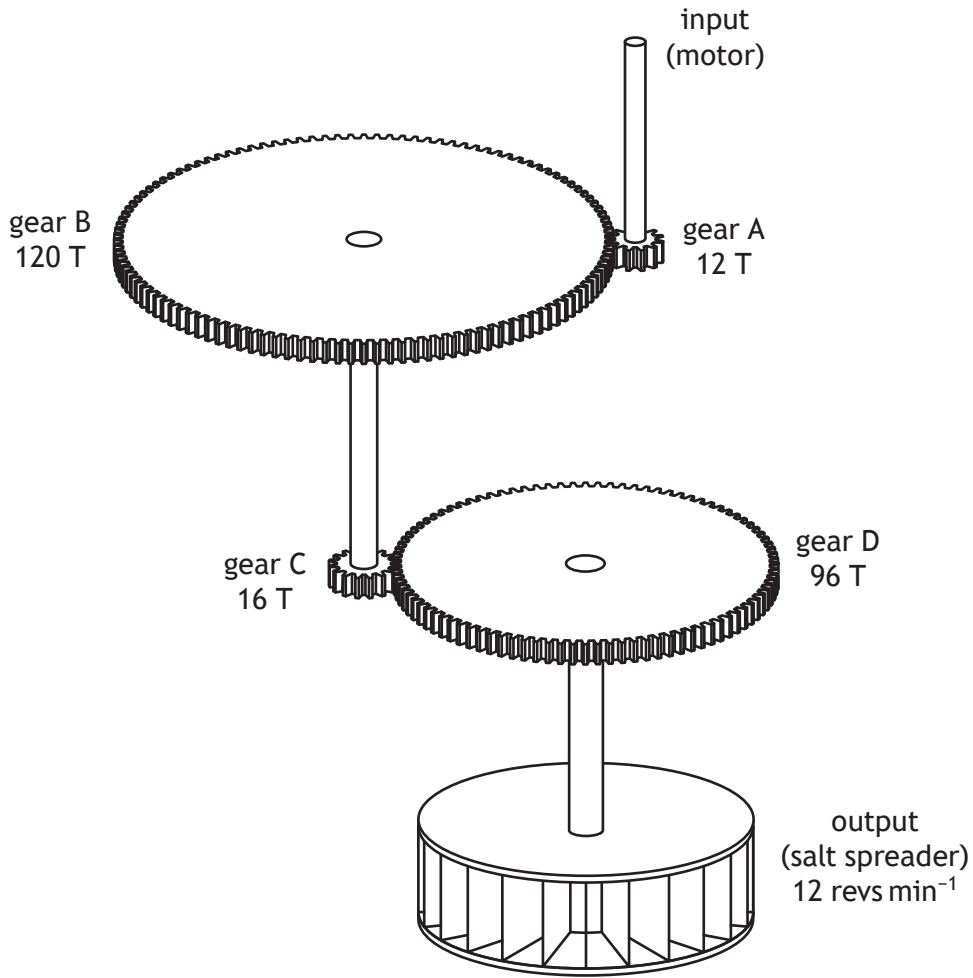

(e) Calculate the **input** speed of the motor.

4



[Turn over for next question

DO NOT WRITE ON THIS PAGE



* X 8 2 3 7 5 0 1 1 7 *

11. A walkway linking two railway platforms is shown.

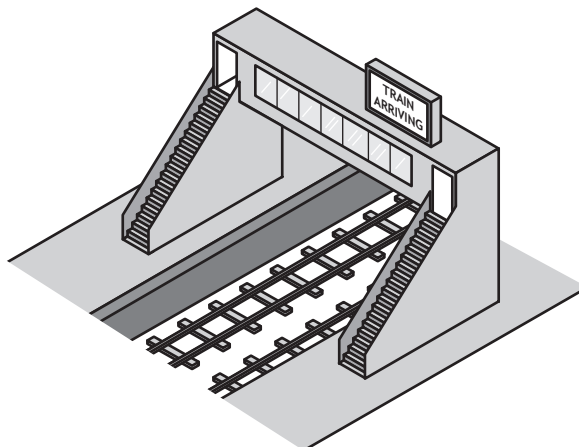

A simplified freebody diagram of the walkway and sign (force F) is shown below.

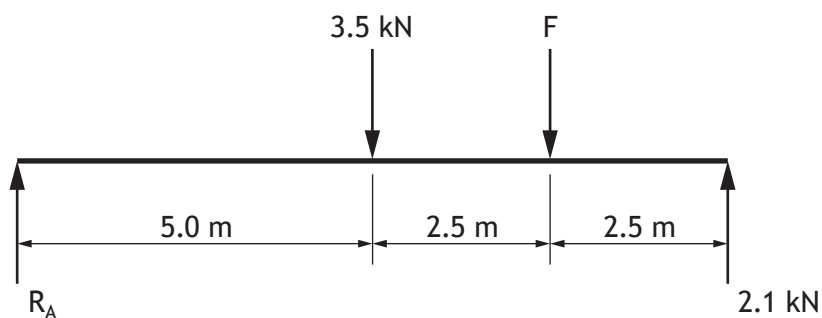

(a) (i) Calculate the force F by taking moments about R_A .

3



11. (a) (continued)

(ii) Calculate the reaction force R_A .

2

Lifts are installed at both ends of the walkway.

(b) (i) Describe one **positive social** impact of installing the lifts.

1

(ii) Describe one **positive economic** impact of installing the lifts.

1

(iii) Describe one **negative economic** impact of installing the lifts.

1

[Turn over



12. A ceiling mounted data projector and support pole are shown.

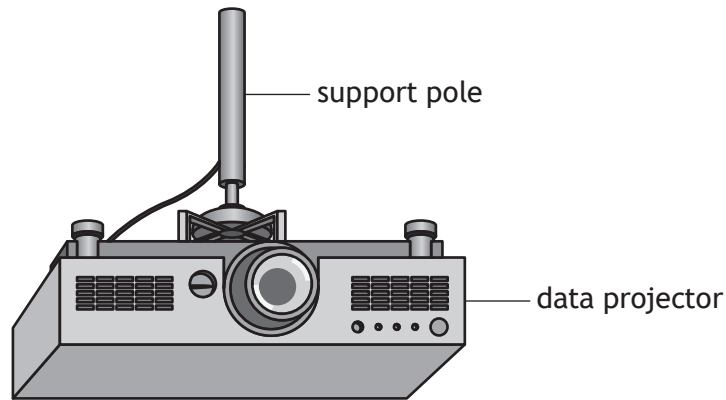

Logic circuits are used to control the data projector. A logic diagram for one of the circuits is shown below.

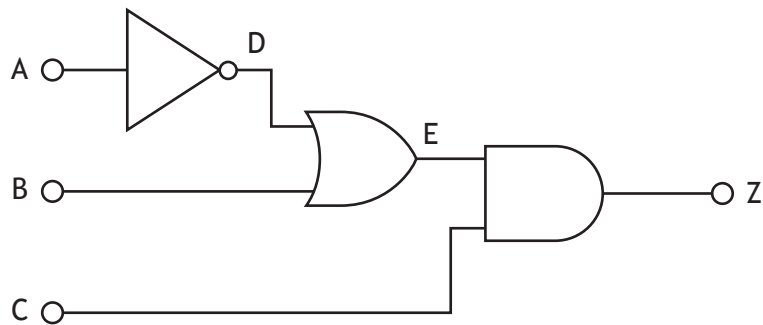

(a) Complete the truth table for the logic diagram shown above.

3

A	B	C	D	E	Z
0	0	0			
0	0	1			
0	1	0			
0	1	1			
1	0	0			
1	0	1			
1	1	0			
1	1	1			

12. (continued)

The Boolean equation for a second logic circuit is given below.

$$(L \cdot M) + \bar{N} = Y$$

(b) Complete the logic diagram below for this Boolean equation.

3

L ○

M ○

○ Y

N ○

(c) Describe two **advantages** of using computer simulation to test a logic circuit before constructing a prototype.

2

1 _____

2 _____



12. (continued)

The support pole used to hold the data projector has a cross-sectional area of 190 mm^2 and a stress of 0.84 N mm^{-2} .

- (d) (i) Calculate the force acting on the support pole.

3

- (ii) State the **nature** of the force in the support pole as the data projector pulls down on it.

1

The pole supporting the data projector is replaced with one which has a larger cross-sectional area.

- (e) Describe the effect this will have on the stress in the support pole.

1

[Turn over



13. A hoverboard is shown.



Part of the circuit used in the control of the hoverboard is shown below.

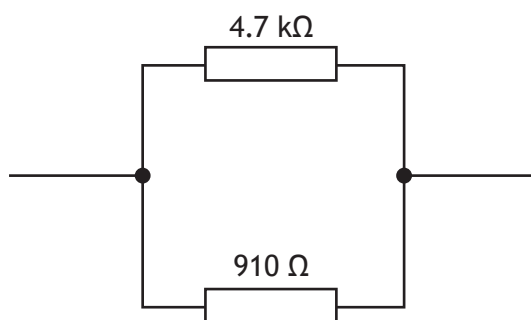

(a) (i) Calculate the total resistance of the circuit.

2

(ii) Draw the symbol for a voltmeter, connected **on the circuit above**, to measure the voltage across the $910\ \Omega$ resistor.

2

(iii) Indicate, with an X, **on the circuit above** where an ammeter would be connected to measure the **total current**.

1



13. (continued)

Part of a second circuit used in the hoverboard is tested using a 36 V supply.

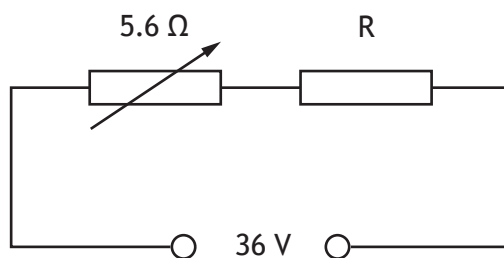

(b) Calculate the value of resistor R to ensure that the circuit current is 2.0 A.

4

[Turn over



13. (continued)

The hoverboard and rider have a combined mass of 64 kg.

- (c) Calculate the kinetic energy of the hoverboard and rider when they are travelling at 3.4 m s^{-1} .

2

The hoverboard is an established technology.

A driverless car is an **emerging technology** that is not yet established.

- (d) Explain a possible impact of driverless cars on **road safety**.

2



14. Hydropower is used to produce electricity from stored water in a reservoir. A diagram of a hydropower station is shown.

MARKS DO NOT WRITE IN THIS MARGIN

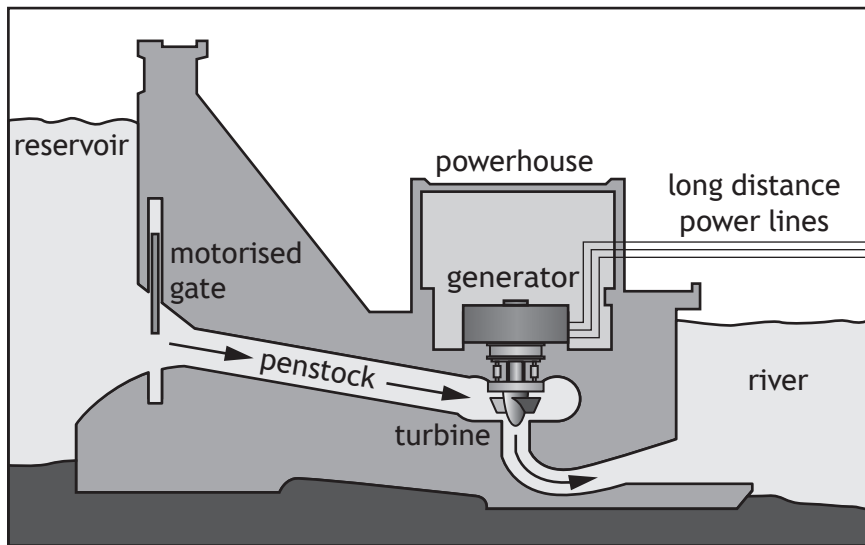

A steady flow rate of water must move through the penstock to rotate the turbine. The water flow rate is adjusted by a motorised gate which can move up or down.

A sub-system diagram for the control of the motorised gate is shown.

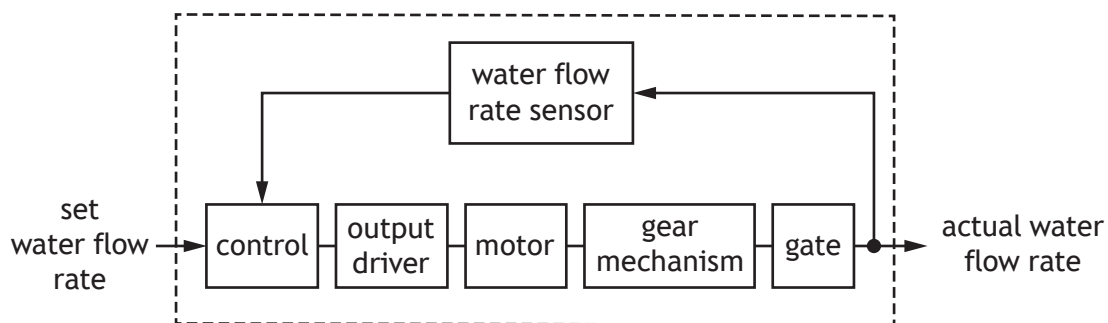

- (a) Describe (with reference to the sub-system diagram) the operation of the system.

5



14. (continued)

Part of the gear mechanism used to control the gate movement has a velocity ratio of 14:1 and an input speed of $870 \text{ revs min}^{-1}$.

(b) Calculate the output speed of this part of the gear mechanism.

3

A microcontroller is used in the control of the hydropower station.

(c) Describe one **advantage** of using a microcontroller instead of a hard wired circuit.

1



14. (continued)

The hydropower station is 0.85 (85%) efficient and generates an output power of 15 MW.

(d) Calculate the input power.

3

(e) Explain the impact of using hydropower on climate change.

2

[Turn over



15. A pneumatic circuit is used in part of a manufacturing process.

MARKS DO NOT WRITE IN THIS MARGIN

- (a) Complete the piping of the pneumatic circuit below to outstroke the piston in cylinder (A) when valve (1) and valve (2) are actuated. The piston will instroke when valve (3) is actuated.

5

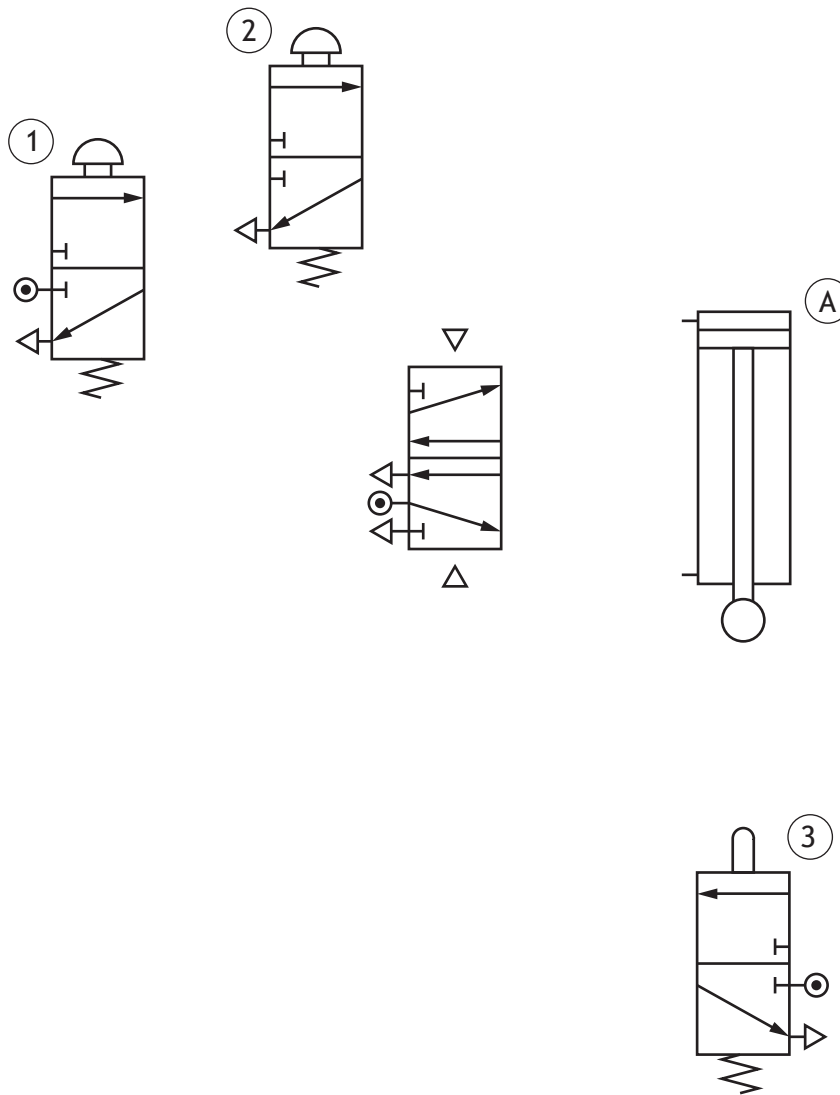

The speed of the piston movement needs to be slowed down.

- (b) Draw the symbol for a uni-directional restrictor to slow the air flow in the direction shown.

2

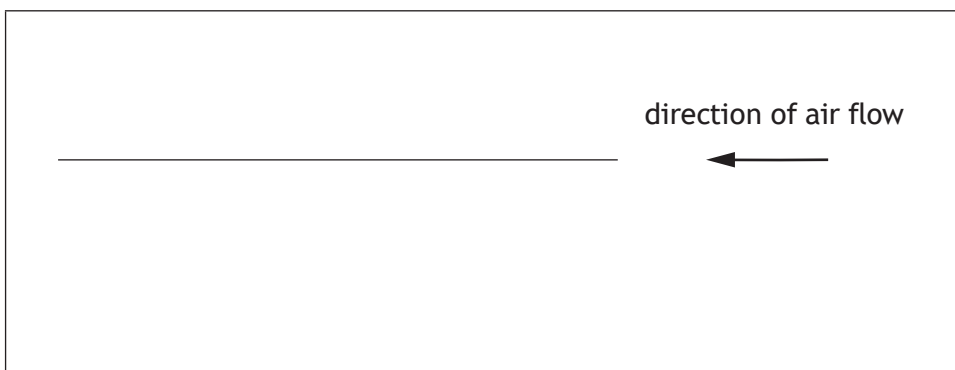

15. (continued)

Cylinder (A) is supplied with an air pressure of 1.4 N mm^{-2} and the piston has an outstroking force of 490 N.

(c) Calculate the area of the piston in cylinder (A).

3

An engineer compared the size of the outstroke force and the instroke force of a double-acting cylinder when supplied with the **same** air pressure.

The result of the test showed that there was a difference in the size of the two forces.

(d) Explain the difference in the size of these two forces.

2

[END OF QUESTION PAPER]



MARKS DO NOT
WRITE IN
THIS
MARGIN

ADDITIONAL SPACE FOR ANSWERS



* X 8 2 3 7 5 0 1 3 2 *

MARKS DO NOT
WRITE IN
THIS
MARGIN

ADDITIONAL SPACE FOR ANSWERS



* X 8 2 3 7 5 0 1 3 3 *

[BLANK PAGE]

DO NOT WRITE ON THIS PAGE



* X 8 2 3 7 5 0 1 3 4 *

[BLANK PAGE]

DO NOT WRITE ON THIS PAGE



* X 8 2 3 7 5 0 1 3 5 *

[BLANK PAGE]

DO NOT WRITE ON THIS PAGE

Acknowledgement of copyright

Question 8 symbiot/shutterstock.com
Question 10 Editorial image: antb/shutterstock.com
Question 13 maxbelchenko/shutterstock.com



* X 8 2 3 7 5 0 1 3 6 *