

N5

National 5
Coursework
Assessment Task



National 5 Engineering Science Assignment Assessment task: toy shop

Valid for session 2023-24 only.

This assessment is given to centres in strictest confidence. You must keep it in a secure place until it is used.

This edition: January 2024 (version 1.0)

© Scottish Qualifications Authority 2024

Contents

Introduction	1
Instructions for teachers and lecturers	2
Instructions for candidates	6
Worksheets	24

Introduction

This document contains instructions for teachers and lecturers, and instructions for candidates for the National 5 Engineering Science assignment. It must be read in conjunction with the course specification.

This assignment has 50 marks out of a total of 160 marks available for the course assessment.

This is one of two course assessment components. The other component is a question paper.

Instructions for teachers and lecturers

This task is valid for session 2023-24 only. Once complete, you must send the assignment responses to SQA to be marked.

You must conduct the assignment under a high degree of supervision and control.

This means:

- ◆ all candidates must be within your direct sight
- ◆ candidates must not interact with each other
- ◆ candidates must not have access to e-mail, the internet and mobile phones
- ◆ candidates must complete their work independently – no group work is permitted
- ◆ classroom display materials that might provide assistance must be removed or covered
- ◆ there must be no interruption for learning and teaching
- ◆ candidates must be in a classroom environment

Time

Candidates have 8 hours to complete the assignment, starting at an appropriate point in the course after all content has been delivered. Once candidates begin their assignment, they must continue in each subsequent class period until the permitted time allocation has been used up.

You have a responsibility to manage candidates' work, distributing it at the beginning and collecting it at the end of each period, and storing it securely in-between. This activity does not count towards the total time permitted for candidates to complete the assignment.

Resources

This is a closed-book assessment. Candidates must not have access to learning and teaching materials, the internet, notes, exemplar materials, resources on classroom walls or anything similar.

A data booklet containing relevant data and formulae is available on the National 5 Engineering Science subject page on SQA's website. This can be used for the assignment.

Each assessment task includes instructions and details of any equipment or materials required for the assignment. Candidates can also use normal classroom equipment, software and hardware (such as drawing instruments, pneumatics, mechanisms and electronics kit, simulation software, and PCs to run the software) to complete the tasks.

There may be instances where restriction of internet and/or network use is not practical or feasible (for example, a local authority-managed network with specific limitations, software that is web-based, or something similar), however, it remains your professional responsibility to make every effort to meet the assessment conditions.

Reasonable assistance

Candidates must progress through each stage of the assignment without your intervention or guidance, having acquired the skills earlier in the course.

Once candidates complete the assignment, you must not return it to them for further work. You must not provide feedback to candidates or offer your opinion on the perceived quality or completeness of the assignment response at any stage.

You can provide reasonable assistance to support candidates with the following aspects of their assignment:

- ◆ printing, collating and labelling their evidence to ensure it is in the format specified by SQA
- ◆ ensuring candidates have all the materials and equipment required to complete the assignment
- ◆ understanding the information outlined in these instructions

Evidence

All candidate evidence (whether created manually or electronically) must be submitted to SQA in paper-based format.

Each task details what evidence is required and how many pages are expected. This is a guide to ensure that candidates do not produce too much or spend too long on a single task.

Candidates must submit single-sided A4 pages. The pages must not have anything fixed to them. Any screenshots, simulation printouts and/or images must be clear and easy to read.

Alteration or adaptation

You must not alter, adapt or modify the assignment in any way. This includes moving the content of the assignment into a different format or workbook. All candidates must undertake the assignment exactly as it is provided by SQA.

Submission

Each piece of work must be labelled with the task number, for example, task 2a, and the back of each page must be clearly labelled with the candidate's details.

Photographs must show the candidate's name next to the piece of work.

Only pages containing candidate evidence are to be submitted and evidence must be submitted in task order.

Volume

There is no word or page count.

Specific instructions for teachers and lecturers: 2023-24 assignment

You must follow these specific instructions. You must ensure that candidates are aware of the assessment conditions and know what they should do for each task and any specific information contained in this section.

This assignment has **five** mandatory tasks. Candidates can complete the tasks in the order presented or in an order that helps manage classroom equipment.

Each task has a notional time allocated to it – this provides an indication of how long candidates should spend on the task.

All tasks must be completed on A4 single-sided paper or the worksheets provided, with the task number clearly labelled.

Any evidence printed (screenshots or images) must be clear and easy to read.

Task 1 (7 marks)

Notional time: 1 hour 30 minutes

- ◆ completed on up to two single-sided A4 pages
- ◆ tasks 1a and 1b: worksheets are provided for these tasks

Task 2 (14 marks)

Notional time: 2 hours 15 minutes

- ◆ completed on up to four single-sided A4 pages
- ◆ task 2c: worksheet is provided for this task

Task 3 (14 marks)

Notional time: 2 hours

- ◆ completed on up to four single-sided A4 pages
- ◆ task 3a(i), 3a(ii), 3b and 3c: worksheets are provided for these tasks
- ◆ task 3b: candidates must not construct or use simulation software for this task

Task 4 (9 marks)

Notional time: 1 hour 30 minutes

- ◆ completed on up to four single-sided A4 pages
- ◆ tasks 4a, 4b and 4d: worksheets are provided for these tasks
- ◆ task 4b: candidates must not construct or use simulation software for this task

Task 5 (6 marks)

Notional time: 45 minutes

- ◆ completed on up to four single-sided A4 pages
- ◆ tasks 5a and 5c: worksheets are provided for these tasks
- ◆ task 5a: candidates must not construct or use simulation software for this task

Note: electronically-generated evidence (for example simulations and coding) is included in the expected number of pages for each task. This must be printed off and compiled for uplift by SQA.

Instructions for candidates

This assessment applies to the assignment for National 5 Engineering Science.

This assignment has 50 marks out of a total of 160 marks available for the course assessment.

It assesses the following skills, knowledge and understanding:

- ◆ demonstrating engineering science skills and creativity
- ◆ analysing engineering problems
- ◆ designing and building (simulating and/or constructing) solutions to engineering problems
- ◆ testing and evaluating solutions to engineering problems

This is a closed-book assessment. Your teacher or lecturer will let you know how the assessment will be carried out and any specific conditions for doing it.

In this assessment, you have to:

- ◆ analyse a problem
- ◆ design a solution to the problem
- ◆ simulate or construct your solution
- ◆ test your solution
- ◆ evaluate your work

You have 8 hours to complete the assignment. The time to set up and clear away equipment you will need, and for any printing that is necessary, does not count towards the 8 hours.

You should complete all of the tasks in the order presented, unless otherwise instructed.

The assignment has five tasks, with marks allocated as follows:

Task 1 – 7 marks: evaluating and designing a solution (pneumatics) for the model railway.
(evaluating = 2 marks, designing a solution = 5 marks)

Task 2 – 14 marks: building and testing a solution (electronics/programmable control) for the interactive teddy bear.
(building = 8 marks, testing = 6 marks)

Task 3 – 14 marks: analysing, designing and evaluating a solution (electronics) for the shop front night setting.
(analysis = 8 marks, designing a solution = 3 marks, evaluating = 3 marks)

Task 4 – 9 marks: building, testing, designing and evaluating a solution (mechanisms) for the revolving display.
(building = 2 marks, testing = 2 marks, designing a solution = 2 mark, evaluating = 3 marks)

Task 5 – 6 marks: designing, building, testing and evaluating a solution (electronics) for the toy safe.
(designing a solution = 2 marks, building = 2 marks, evaluating = 2 marks)

For each task, you are provided with an engineering science context or situation.

Submitting your work

Your teacher or lecturer will let you know the approximate amount of time to spend on each task, along with any specific information you need and an indication of the number of single-sided A4 pages of evidence that you should produce.

You must label each piece of your work with the task number (for example, task 2a), and on the back of each page include your:

- ◆ name
- ◆ date of birth
- ◆ Scottish Candidate Number (SCN)
- ◆ centre name
- ◆ centre number

Candidate data sheets – toy shop

You can use these data sheets and SQA's National 5 data booklet when completing this assignment. No other resource material is permitted.

Electronic symbols

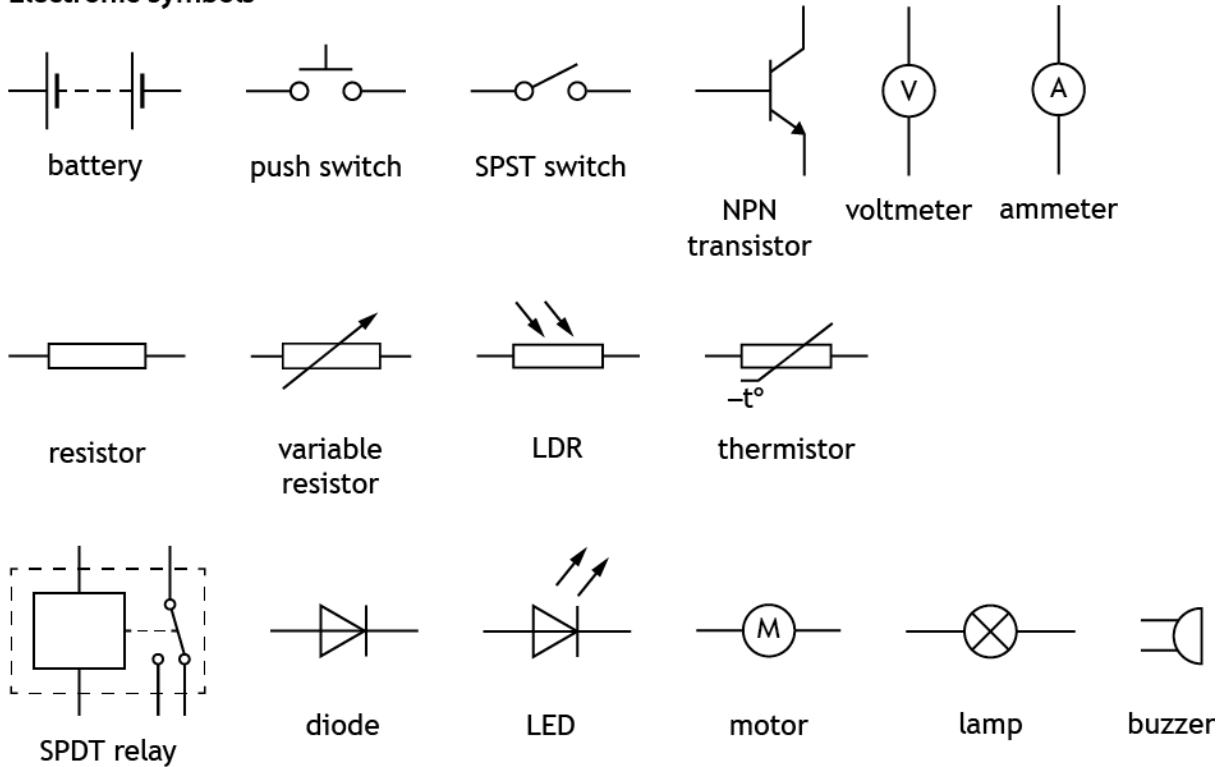

IC pinout diagrams

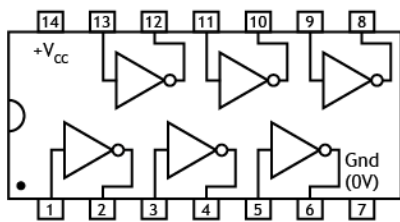

7404 hex inverter
(NOT gates)

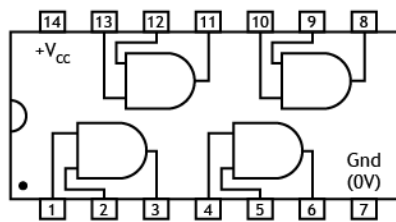

7408 quad 2 input
AND gates

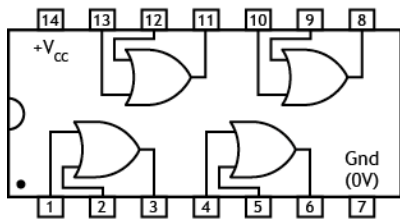

7432 quad 2 input
OR gates

Logic gates

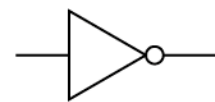

NOT gate

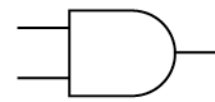

AND gate

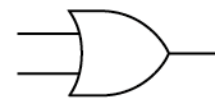

OR gate

Pneumatic symbols

Actuators



spring return



pilot air



roller



solenoid



lever



diaphragm



roller trip



plunger



push button

Valves

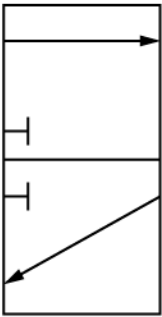

3/2 valve

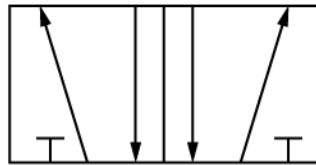

5/2 valve

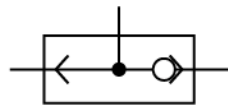

shuttle valve



main air



exhaust

Components and cylinders



unidirectional restrictor



reservoir

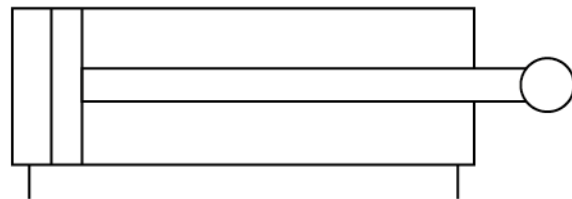

double acting cylinder

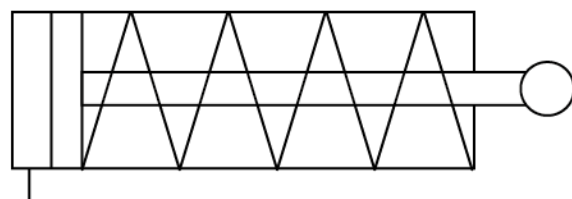

single acting cylinder

Light Dependent Resistor (LDR) graph for an ORP12 LDR

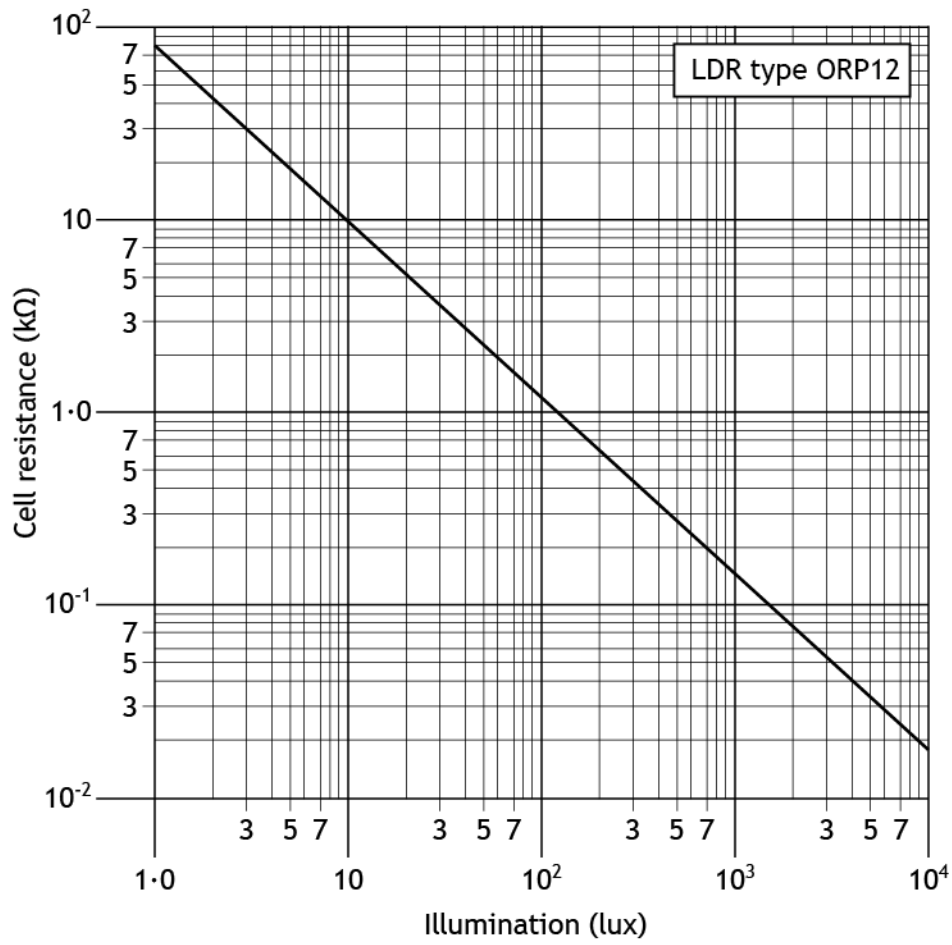

Thermistor graph

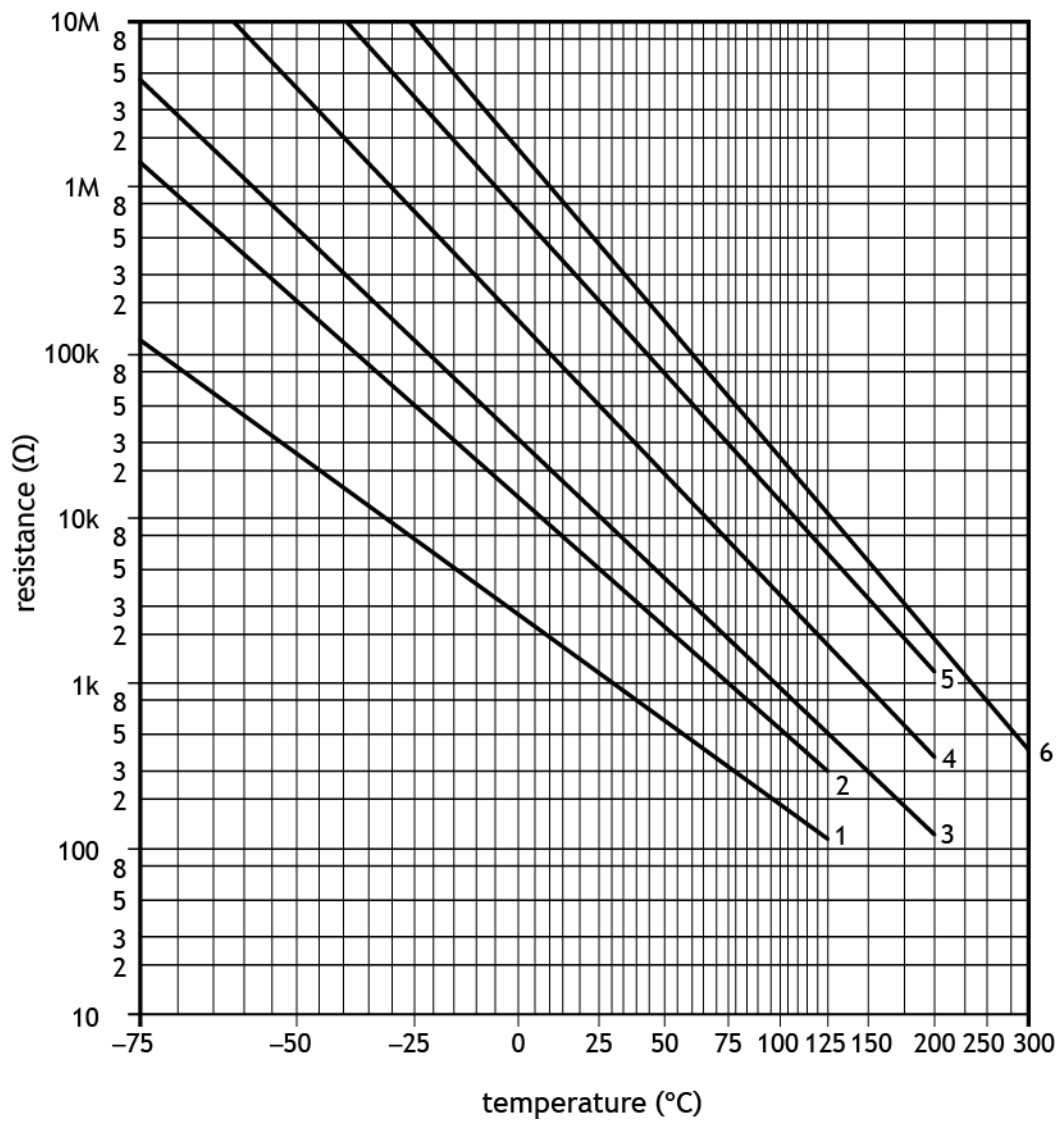

Toy shop

A team of engineers is involved in developing a range of systems for a toy shop.

The tasks include developing proposals for the following:

Task 1 – model railway

Task 2 – interactive teddy bear

Task 3 – shop front night setting

Task 4 – rotating display stand

Task 5 – toy safe

Task 1 – model railway

A model railway display in the toy shop lets trains travel around a series of tracks.



It needs a pneumatic circuit to switch the rails between two sets of tracks, then return them automatically after the train has passed.

The pneumatic circuit must meet the following specification:

- i When a push button actuator on a 3/2 valve is pressed, a 5/2 valve will cause the piston in a double-acting cylinder to outstroke slowly and smoothly.
- ii An actuator on a second 3/2 valve will detect when a train has passed.
- iii After a pneumatic time delay, the piston will instroke slowly and smoothly.

The table below shows possible actuators that could detect when a train has passed.

Type	Actuator
Electrical	solenoid
Mechanical	roller, roller trip, plunger
Pneumatic	diaphragm
Manual	lever, push button

1a Choose a suitable actuator from the table above, to sense when a train has passed.

Complete **worksheet 1a**, justifying your choice.

Present your evidence on A4 single-sided pages, with the task number clearly labelled.

(2 marks)

Task 1 – model railway (continued)

- 1b Complete the design for the pneumatic circuit on **worksheet 1b**, to meet the specification, using your selected actuator from **task 1a**.

You must identify the name of each component, valve, and actuator, and indicate the direction of the piston outstroke. Show connections between all components and valves.

You can simplify components. For example, you could draw a 5/2 valve as shown below.

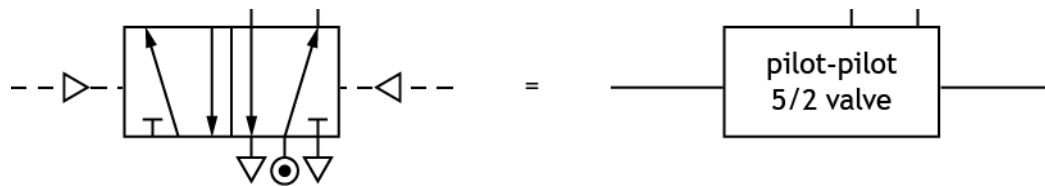

Present your evidence on A4 single-sided pages, with the task number clearly labelled.

(5 marks)

Task 2 – interactive teddy bear

The toy shop owner wants an interactive teddy bear to entertain customers. It will have a motorised bow-tie with flashing LEDs.

An electronic engineer has designed a possible microcontroller-based solution.

The pin numbers used to connect an electronic circuit to the microcontroller are shown in the table below.

Input	Pin	Output
	7	motor
	5	LEDs
test switch	2	
movement sensor	0	

- 2a Simulate the flowchart sequence and electronic circuit **integrated together**, as shown on the following page. You can use a different sized microcontroller but the pin numbers must match the connections given.

Note: for test purposes, the movement sensor is replaced with a push-to-make switch.

Present your evidence on A4 single-sided pages, with the task number clearly labelled. Screenshots or images must be clear and easy to read.

(5 marks)

Task 2 – interactive teddy bear (continued)

Microcontroller-based solution

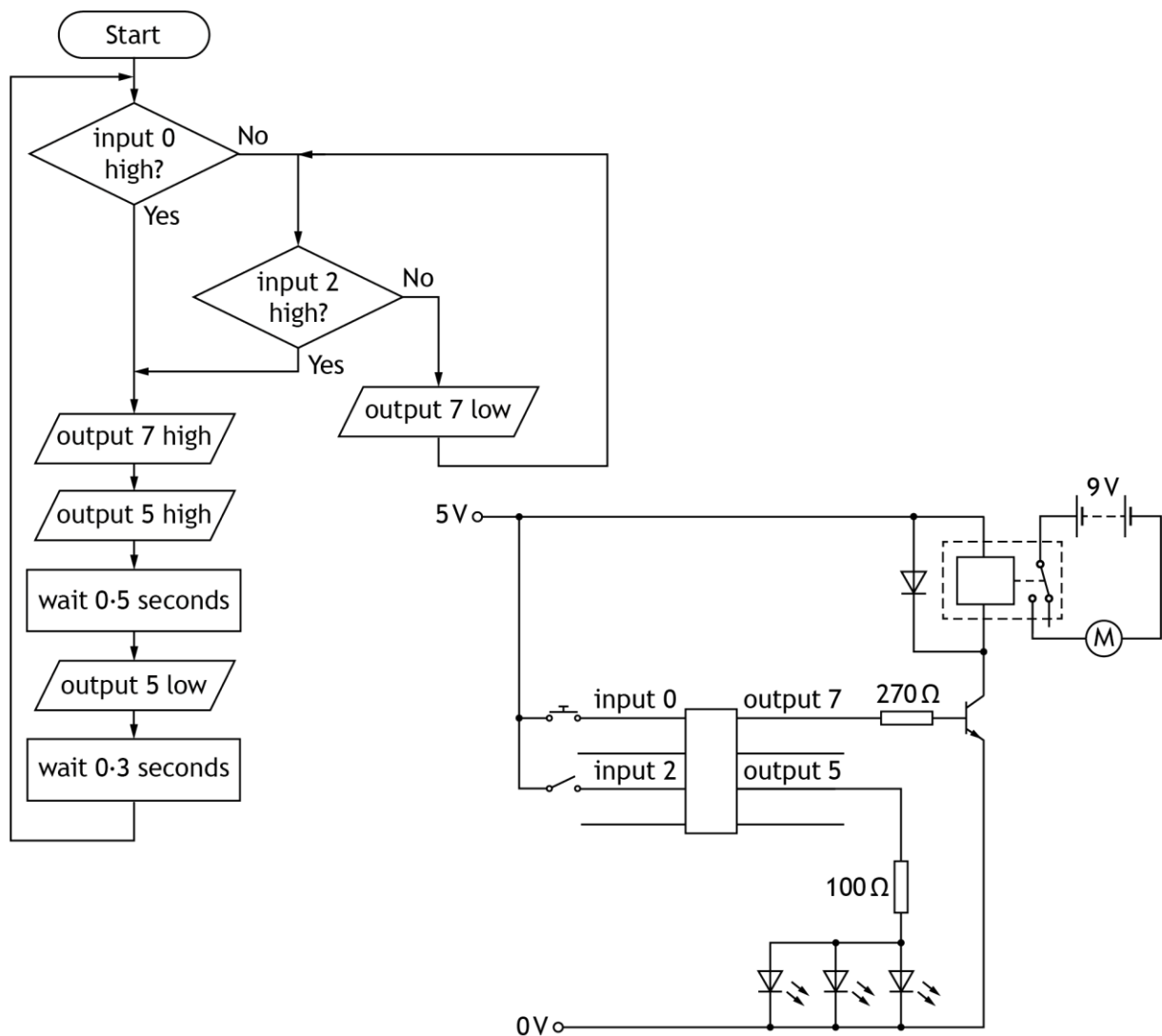

2b Produce high-level microcontroller code to fully match the flowchart from **task 2a**.

Present your evidence on A4 single-sided pages, with the task number clearly labelled. Screenshots or images must be clear and easy to read.

(1 mark)

Task 2 – interactive teddy bear (continued)

The microcontroller must meet the following specification:

- i Whenever the test switch (input 2) is activated, the motor will rotate, and the LEDs will flash on and off continuously.
- ii Whenever the movement sensor (input 0) detects a customer, the motor will rotate, and the LEDs will flash on and off continuously.
- iii When the movement sensor no longer detects a customer, the motor and the LEDs will switch off.

Errors were found in both the flowchart and electronic circuit during testing.

- 2c Complete the testing table on **worksheet 2c**, by carrying out the planned tests and describing each initial test result.

Describe your planned amendments to the flowchart and/or circuit, so that it meets the specification and make the amendments.

Carry out each test again, describing the result of your retest, before moving onto the next test.

Present your evidence on A4 single-sided pages, with the task number clearly labelled.

(6 marks)

- 2d Your final amended flowchart and electronic circuit should now meet the specification given at the start of **task 2c**.

Present your evidence of your amended flowchart and electronic circuit integrated together, on A4 single-sided pages, with the task number clearly labelled. Screenshots or images must be clear and easy to read.

(2 marks)

Task 3 – shop front night setting

A microcontroller-based circuit is needed to operate a light above the shop's sign and a motorised blind in the shop window. The circuit must meet the following specification:

- i A sensor will detect the outside light level.
- ii When it is dark, the microcontroller will switch on the lamp and turn the motor to fully close the blind.
- iii When it is light, the microcontroller will then switch off the lamp and turn the motor to fully open the blind.
- iv Two limit switches will send feedback signals to the microcontroller. The microcontroller will stop the motor when either the blind is fully open or fully closed.

3a(i) Complete the system diagram on **worksheet 3a(i)** to meet the specification.

You must clearly show all external inputs and outputs.

Present your evidence on A4 single-sided pages, with the task number clearly labelled.

(2 marks)

(ii) Complete the sub-system diagram on **worksheet 3a(ii)** to meet the specification.

You must clearly show all external inputs and outputs, all sub-systems, the system boundary and the interactions between sub-systems.

Note: each output device requires a driver.

Present your evidence on A4 single-sided pages, with the task number clearly labelled.

(6 marks)

A dark sensor is needed to detect the outside light level and send a signal to the microcontroller.

3b Complete the circuit diagram on **worksheet 3b**, by designing a suitable input sensing circuit that will produce a high signal (V_{out}) when it is dark. Component values are not required.

Note: you must not construct or use simulation software to complete this part of the task.

Present your evidence on A4 single-sided pages, with the task number clearly labelled.

(3 marks)

Task 3 – shop front night setting (continued)

3c Using the input sensor circuit you designed in **task 3b**, complete the test plan on **worksheet 3c** by describing:

- ◆ the expected result from the planned test given in terms of V_{out}
- ◆ a second planned test and the expected result in terms of V_{out} .

Present your evidence on A4 single-sided pages, with the task number clearly labelled.

(3 marks)

Task 4 – rotating display stand

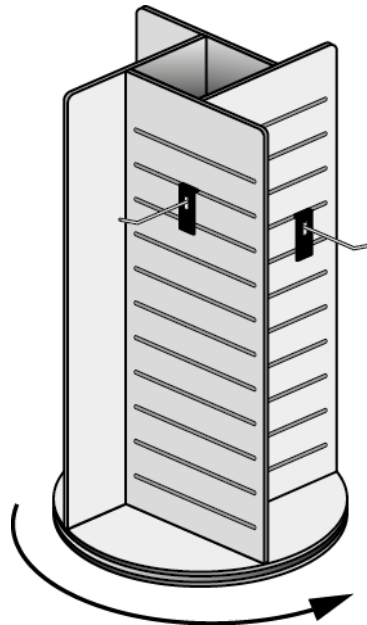

A rotating display stand needs a motorised gear train that will meet the following specification:

- i It must fit into a compact space inside the rotating display stand.
- ii The output gear D must turn in the same direction as the input gear A.
- iii It must reduce the speed of the output by at least a factor of 6 but not greater than a factor of 9.

An initial design for the gear train is shown below, with gear sizes and input speed.

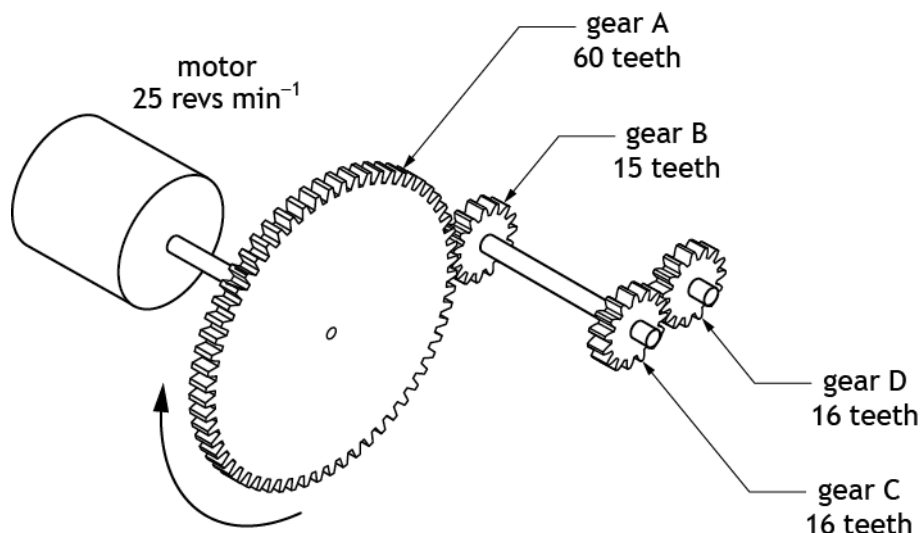

Task 4 – rotating display stand (continued)

4a Evaluate the initial gear train design against the specification and complete the table on **worksheet 4a**. You should:

- ◆ state if each specification point is met
- ◆ justify your decision

Present your evidence on A4 single-sided pages, with the task number clearly labelled.

(3 marks)

The display stand speed is found to be unsuitable.

4b Design a gear train on **worksheet 4b**, based on the gear sizes available to you. This needs to give a speed reduction of at least a factor of 12, but not greater than a factor of 20. Label the input gear and include all gear sizes.

Note: you must not construct or use simulation software to complete this part of the task.

Present your evidence on A4 single-sided pages, with the task number clearly labelled.

(2 marks)

4c Simulate or construct your design from **task 4b**. You must include an input component to allow for testing and label all gear sizes.

Present your evidence on A4 single-sided pages, with the task number clearly labelled. Screenshots or images must be clear and easy to read.

(2 marks)

4d Complete the test result table on **worksheet 4d** by:

- ◆ entering the results from **task 4c** that you observed during simulation or after construction
- ◆ calculating the actual velocity ratio, using your recorded values for the input and output speeds

Present your evidence on A4 single-sided pages, with the task number clearly labelled.

(2 marks)

Task 5 – toy safe

The shop owner wants to run a competition where customers try to solve the code to open a toy safe and win a prize.



- 5a Complete the logic diagram on **worksheet 5a** to unlock the safe by sending a high (1) signal to output Z when:

input A is high (1) and input B is low (0) and input C is high (1)

Note: you must not construct or use simulation software to complete this part of the task.

Present your evidence on A4 single-sided pages, with the task number clearly labelled.

(2 marks)

Task 5 – toy safe (continued)

Another code for the toy safe was designed using the logic diagram shown below.

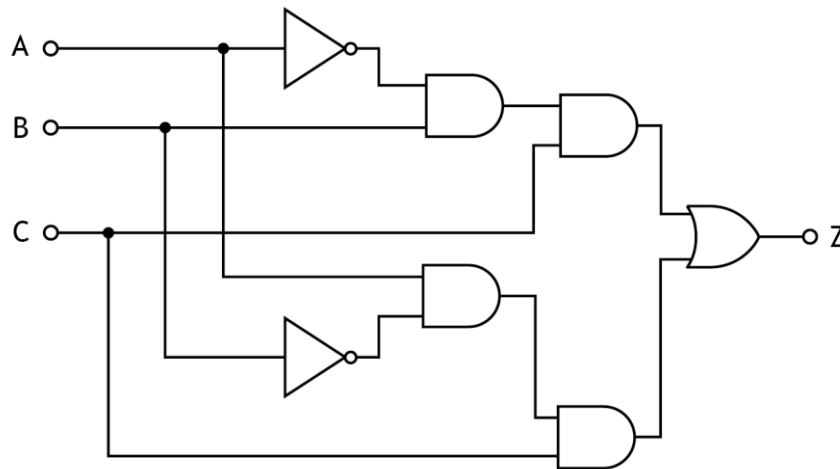

- 5b Simulate or construct the logic diagram shown above. You must include suitable input and output devices to allow for potential testing. If constructed, you must clearly label the integrated circuit (IC) numbers.

Present your evidence on A4 single-sided pages, with the task number clearly labelled. Screenshots or images must be clear and easy to read.

(2 marks)

- 5c Using **worksheet 5c**, describe a suitable modification to the logic circuit in **task 5b** that would make the code for the toy safe harder to solve and justify your reason.

Present your evidence on A4 single-sided pages, with the task number clearly labelled.

(2 marks)

[END OF ASSIGNMENT]



National 5
Coursework
Assessment Task



National 5 Engineering Science Assignment Assessment task: toy shop

Worksheets

Valid for session 2023-24 only.

Worksheet 1a

Actuator	
Justification	

(2 marks)

Name:	
Date of birth:	
Scottish Candidate Number (SCN):	
Centre name:	
Centre number:	

Worksheet 1b

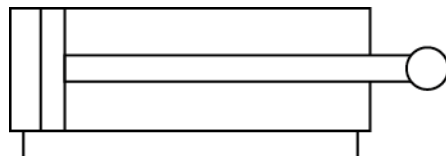

(5 marks)

Name:	
Date of birth:	
Scottish Candidate Number (SCN):	
Centre name:	
Centre number:	

Worksheet 2c

Planned test	Expected result	Initial test result	Planned amendment to circuit/flowchart	Retest result
Test 1 Turn on the test switch (input 2) for around 20 seconds and then turn it off.	The motor starts to turn and the LEDs flash. When the test switch is turned off, the LEDs turn off and the motor slows to a stop.	<i>When the test switch is turned on ...</i> <i>When the test switch is turned off ...</i>		<i>When the test switch is turned on ...</i> <i>When the test switch is turned off ...</i>
Planned test	Expected result	Initial test result	Planned amendment to circuit/flowchart	Retest result
Test 2 Press and hold the movement sensor (input 0) for around 20 seconds and then release it.	The motor starts to turn and the LEDs flash. When the movement sensor is released, the LEDs turn off and the motor slows to a stop.	<i>When the movement sensor is pressed ...</i> <i>When the movement sensor is released ...</i>		<i>When the movement sensor is pressed ...</i> <i>When the movement sensor is released ...</i>

(6 marks)

Name:	
Date of birth:	
Scottish Candidate Number (SCN):	
Centre name:	
Centre number:	

Worksheet 3a(i)



(2 marks)

Name:	
Date of birth:	
Scottish Candidate Number (SCN):	
Centre name:	
Centre number:	

Worksheet 3a(ii)

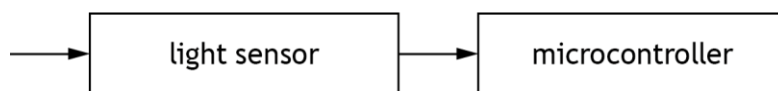

(6 marks)

Name:	
Date of birth:	
Scottish Candidate Number (SCN):	
Centre name:	
Centre number:	

Worksheet 3b

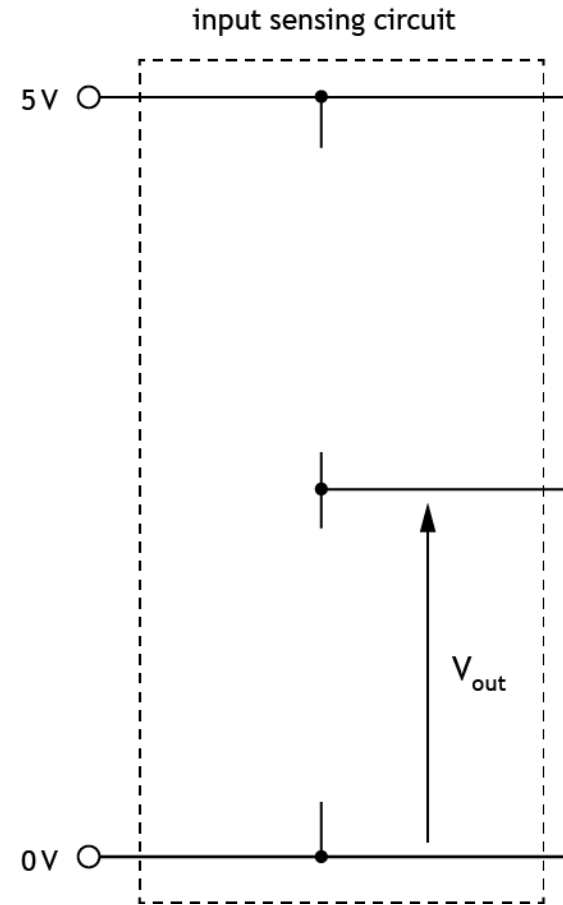

(3 marks)

Name:	
Date of birth:	
Scottish Candidate Number (SCN):	
Centre name:	
Centre number:	

Worksheet 3c

Planned test	Expected result
Test 1 Reduce the light level.	
Planned test	Expected result
Test 2	

(3 marks)

Name:	
Date of birth:	
Scottish Candidate Number (SCN):	
Centre name:	
Centre number:	

Worksheet 4a

Specification point	Met? Yes/No	Justification
i		
ii		
iii		

(3 marks)

Name:	
Date of birth:	
Scottish Candidate Number (SCN):	
Centre name:	
Centre number:	

Worksheet 4b

(2 marks)

Worksheet 4d

Planned test	Input speed	Output speed	Required Velocity Ratio	Actual Velocity Ratio
Measure the input speed and output speed of the gear system and calculate the actual velocity ratio.			Between 12:1 and 20:1	

(2 marks)

Name:	
Date of birth:	
Scottish Candidate Number (SCN):	
Centre name:	
Centre number:	

Worksheet 5a

A ○ —

B ○ —

— ○ Z

C ○ —

(2 marks)

Name:	
Date of birth:	
Scottish Candidate Number (SCN):	
Centre name:	
Centre number:	

Worksheet 5c

Modification	
Justification	

(2 marks)

Name:	
Date of birth:	
Scottish Candidate Number (SCN):	
Centre name:	
Centre number:	

Copyright acknowledgements

Task 1 - Galchenkova Ludmila/Shutterstock.com

Task 5 - luzvykova laroslava/Shutterstock.com

Administrative information

Published: January 2024 (version 1.0)

History of changes

Version	Description of change	Date

Security and confidentiality

This document can be used by practitioners in SQA approved centres for the assessment of National Courses and not for any other purpose.

This document may only be downloaded from SQA's designated secure website by authorised personnel.

© Scottish Qualifications Authority 2024