

FOR OFFICIAL USE



National
Qualifications
2024

Mark

X823/75/01

Engineering Science

FRIDAY, 17 MAY

9:00 AM – 10:50 AM



* X 8 2 3 7 5 0 1 *

Fill in these boxes and read what is printed below.

Full name of centre

Town

Forename(s)

Surname

Number of seat

Date of birth

Day

Month

Year

Scottish candidate number

Total marks — 110

SECTION 1 — 20 marks

Attempt ALL questions.

SECTION 2 — 90 marks

Attempt ALL questions.

Show all working and units where appropriate.

You should refer to the National 4/5 Engineering Science Data Booklet which you have been given.

The number of significant figures expressed in a final answer should be equivalent to the least significant data value given in the question. Answers that have two more figures or one less figure than this will be accepted.

Write your answers clearly in the spaces provided in this booklet. Additional space for answers is provided at the end of this booklet. If you use this space you must clearly identify the question number you are attempting.

Use **blue** or **black** ink.

Before leaving the examination room you must give this booklet to the Invigilator; if you do not, you may lose all the marks for this paper.



* X 8 2 3 7 5 0 1 0 1 *

SECTION 1 — 20 marks

Attempt ALL questions

1. Digital electronic signals can be controlled using logic gates.

(a) State the logic gate with a **single** input that will change a high input to a low output.

1

(b) Draw the symbol for an AND gate.

1

2. The symbol for an electronic component is shown below.

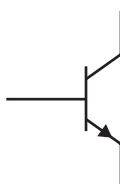

(a) State the name of this component.

1

(b) Indicate with an X, the location of the **base** connection on the symbol shown above.

1



* X 8 2 3 7 5 0 1 0 2 *

3. A diagram for a pneumatic circuit, designed to outstroke a piston when a push button is pressed on a valve, is shown.

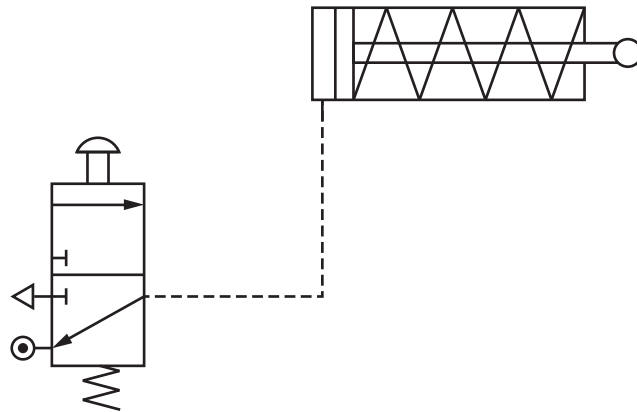

Errors were made in the circuit diagram shown above.

- (a) Describe two errors that were made in this circuit diagram.

2

Error 1 _____

Error 2 _____

- (b) State the type of engineer that would be responsible for designing a pneumatic circuit.

1

[Turn over



* X 8 2 3 7 5 0 1 0 3 *

4. A diagram of a simple gear train is shown below.

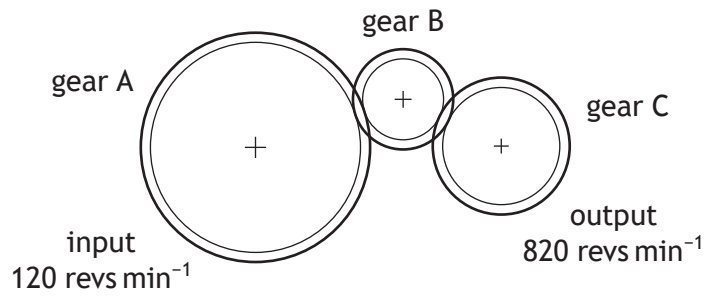

(a) Calculate the velocity ratio of this simple gear train.

2

(b) State the effect on the output velocity if the number of teeth on gear B is reduced.

1



5. A wind farm is being developed on a Scottish island.



(a) State the type of engineer that would be responsible for monitoring:

(i) the construction of the access roads to the wind turbines

1

(ii) the impact on the land during installation of the wind turbines.

1

An incomplete diagram showing the **energy** transformation in a wind turbine is shown below.

(b) Complete the diagram by adding the missing input **energy**.

1

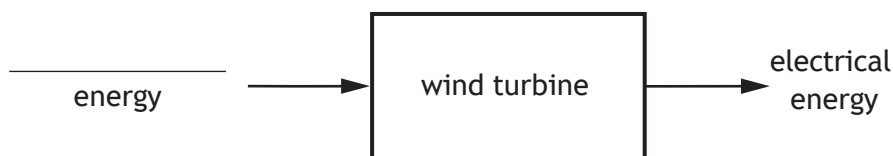

The wind turbine uses feedback in its operation.

(c) State the type of control that uses feedback.

1



6. Members in a frame structure are tested using compressive and tensile forces.

- (a) (i) Draw two arrows which represent an external **compressive** force on member A shown below.

1



member A

- (ii) Draw two arrows which represent an external **tensile** force on member B shown below.

1



member B

Member B has a cross-sectional area of 36 mm^2 .

- (b) Calculate the stress on member B when a 1152 N force is applied.

2



7. Friction can cause the moving parts of a drive system to wear out.

(a) Describe how to reduce the wear on the moving parts of a drive system.

1

(b) State a form of energy lost due to friction in a drive system.

1

[Turn over



* X 8 2 3 7 5 0 1 0 7 *

SECTION 2 — 90 marks

Attempt ALL questions

8. A child's microphone with built-in speaker is shown.



Part of the circuit used to control the volume of the speaker is shown.

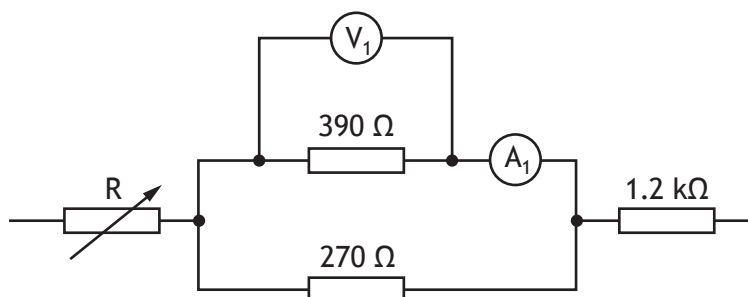

(a) For the circuit shown above:

(i) calculate the resistance of the **parallel** branch

2



8. (a) (continued)

- (ii) calculate the **total resistance** of the circuit when the variable resistor R is set to 780Ω .

2

- (b) Calculate the current reading on ammeter A_1 when the voltage V_1 is 1.2 V.

3

The resistance of the variable resistor R in the circuit is **increased**.

- (c) State the effect this will have on the:

(i) voltage V_1 _____

1

(ii) current A_1 _____

1

During the development of the child's microphone and speaker, computer simulation was used to test the complete circuit before constructing a prototype.

- (d) Explain why it is an advantage to test the circuit using computer simulation before constructing the prototype.

2



9. An electric bike uses a motor to assist a cyclist when pedalling. An electric bike and charging point are shown.



The motor and gear train used in the electric bike are shown below.

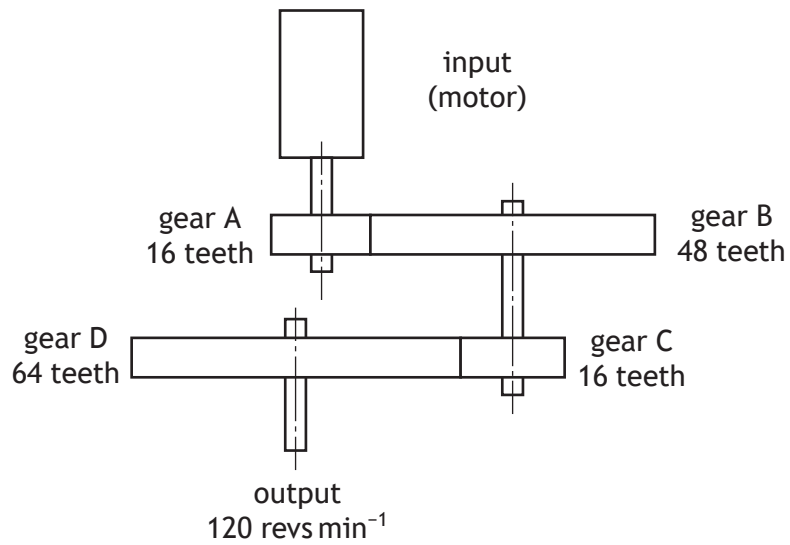

9. (continued)

(a) Calculate the rotational speed of the motor.

4

The motor is rated at 36 V and 250 W.

(b) Calculate the current supplied to the motor.

3



9. (continued)

(c) Explain how the efficiency of the gear train could be improved.

2

(d) Describe one positive **environmental** impact of using an electric bike.

1

(e) Describe one positive **social** impact of using an electric bike.

1

(f) Describe one negative **economic** impact of using an electric bike.

1



10. A kettle is shown below.

MARKS DO NOT WRITE IN THIS MARGIN



A thermistor is used as part of a sensor to measure the water temperature in the kettle.

The operating characteristics for a range of thermistors are shown on the graph below.

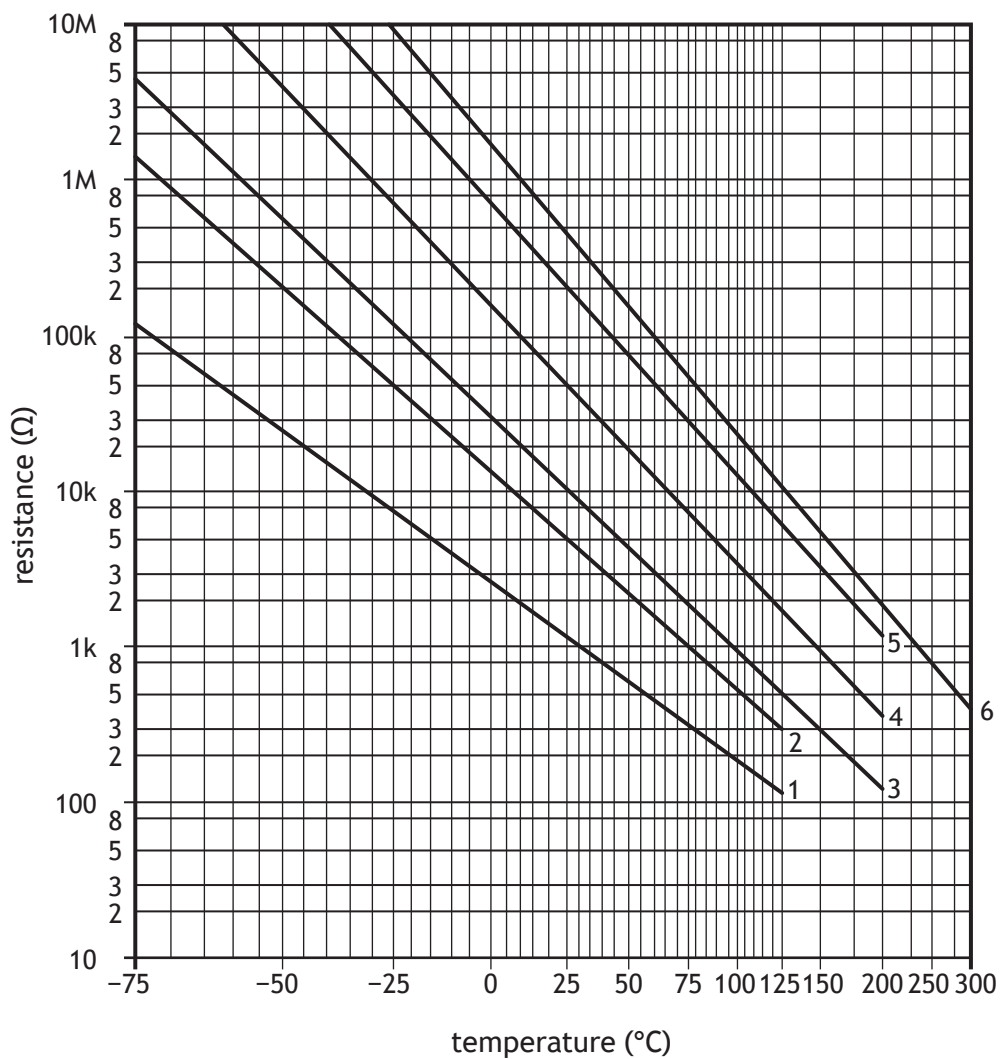

(a) Determine the resistance of a **type 2** thermistor at a temperature of 85 °C, with reference to the graph.

1



10. (continued)

The sensing circuit used to detect the temperature of the water is shown below.

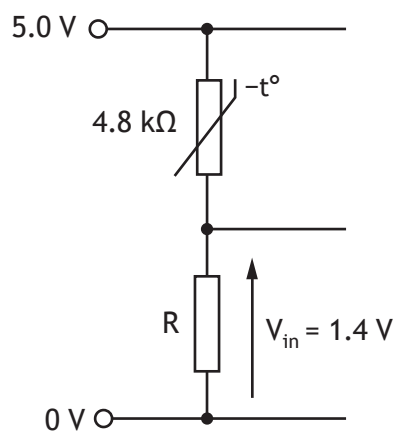

(b) State the name of this type of series circuit.

1

(c) Calculate the resistance R in the sensing circuit shown above.

4



10. (continued)

The kettle has coloured LEDs to indicate the temperature of the water. A simplified circuit used to model the operation of the LEDs is shown below.

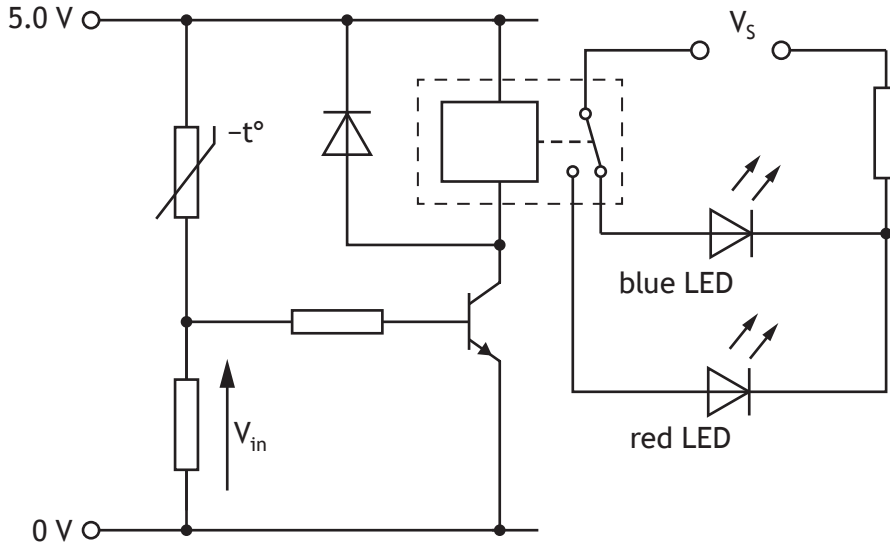

- (d) Describe the operation of this circuit as the water temperature increases. Include reference to the resistance of the thermistor, the voltage V_{in} and both LEDs.

5

As the water temperature increases . . . _____



10. (continued)

A kettle uses established technology.

An **emerging technology** is one that is being developed and still to be tried commercially within a product or system.

- (e) Explain a possible impact of an emerging technology which you are familiar with.

2

Name of emerging technology _____

Impact _____



* X 8 2 3 7 5 0 1 1 6 *

11. A dishwasher in a restaurant kitchen is shown.



Part of the specification for the dishwasher is given below:

- A user selects a set temperature.
- A sensor detects the actual water temperature and sends a signal to the control.
- The control compares the actual water temperature with the set temperature.
- If the actual water temperature is lower than the set temperature a heating element will switch on.

An incomplete sub-system diagram for the dishwasher is shown below.

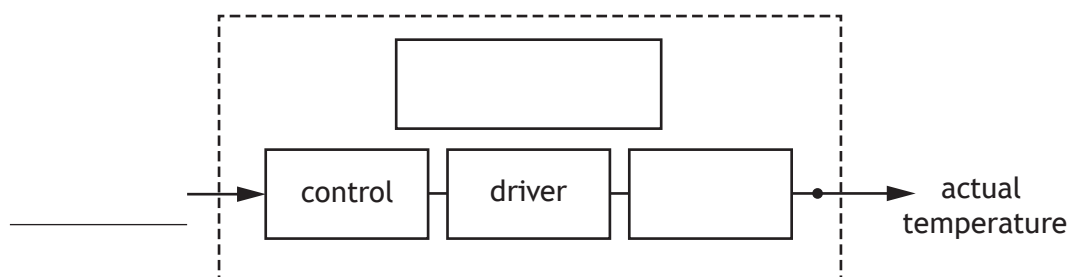

(a) Complete the sub-system diagram with reference to the specification.

4

[Turn over



11. (continued)

The dishwasher is operated by a microcontroller.

Input and output connections to the microcontroller are shown in the table below.

Input connection	Pin	Output connection
	7	red LED
	6	water pump
	5	heating element
	4	buzzer
	3	
start switch	2	
door sensor	1	
	0	

A drying cycle used in the dishwasher operates using the following sequence:

- When a start switch is pressed a red LED will turn on.
- After a door sensor is activated a water pump will turn on for 35 seconds and then turn off.
- A heating element will then turn on for 5 minutes and then turn off.
- A buzzer will then sound six times, turning on for 0.3 seconds and turning off for 0.3 seconds each time.
- The red LED will then turn off.
- The sequence will return to the start.

(b) Complete the flowchart shown opposite for the sequence with reference to the data booklet and input/output connections.

Include **all** pin numbers and delay units in your flowchart.

11



* X 8 2 3 7 5 0 1 1 8 *

11. (b) (continued)

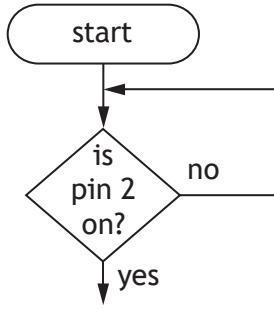

[Turn over



12. A portable power supply used when camping can produce a range of output voltages.

The portable power supply can be charged using solar panels as shown below.



- (a) Explain why using solar panels can contribute towards limiting climate change. 2

A 24 V mini fridge is powered by the portable power supply for 7.5 hours.

- (b) Calculate the electrical energy used by the mini fridge when the current is 0.42 A. 3

12. (continued)

The Boolean equation for part of a circuit used in the portable power supply is shown.

$$Z = (A + B) \cdot (\bar{A} + C)$$

(c) Draw the logic diagram for this Boolean equation.

4

A ○

B ○

○ Z

C ○

[Turn over



* X 8 2 3 7 5 0 1 2 1 *

13. A hydrofoil board allows a rider to glide over water.
The hydrofoil board and handheld wireless controller are shown.

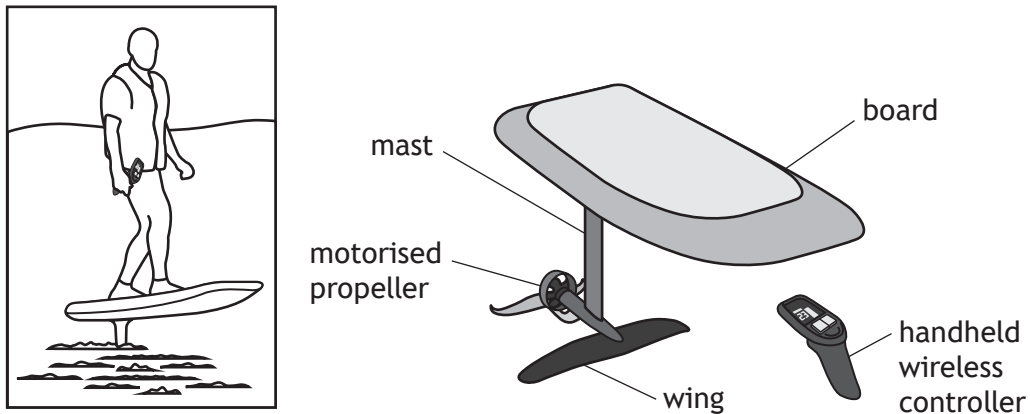

Several different engineers were involved during their development.

- (a) Describe a task that each of the following types of engineer would complete during the **development** of the hydrofoil board and handheld wireless controller:

(i) mechanical engineer

1

(ii) structural engineer

1

(iii) electronic engineer.

1



13. (continued)

The hydrofoil board and rider have a combined mass of 115 kg.

- (b) Calculate the velocity of the hydrofoil board and the rider when their kinetic energy is 13 kJ.

3

The hydrofoil board is to be used in the sea and must be able to withstand a range of different forces.

The properties of four materials considered for the mast are shown in the table below.

Material	Corrosion resistant	Strength
A	yes	low
B	no	high
C	yes	high
D	yes	medium

- (c) Select, from the table, the most suitable material to be used for the mast and justify your choice.

2

Selected material _____

Justification _____

[Turn over



14. A refrigerated lorry trailer used to transport fresh food is shown below.

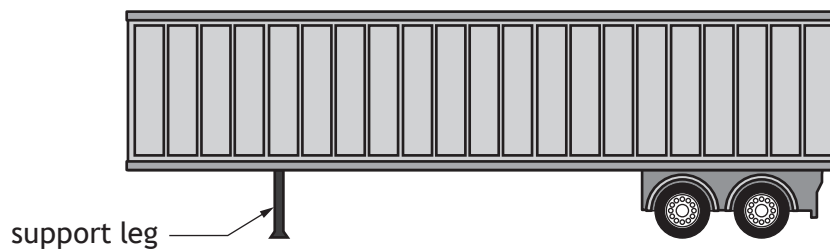

A simplified free body diagram for the empty lorry trailer is shown.

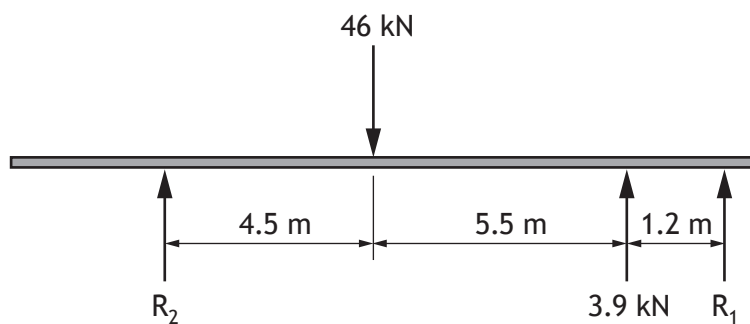

(a) (i) Calculate the reaction force R_1 by taking moments about R_2 .

3



14. (a) (continued)

(ii) Calculate the reaction force R_2 .

2

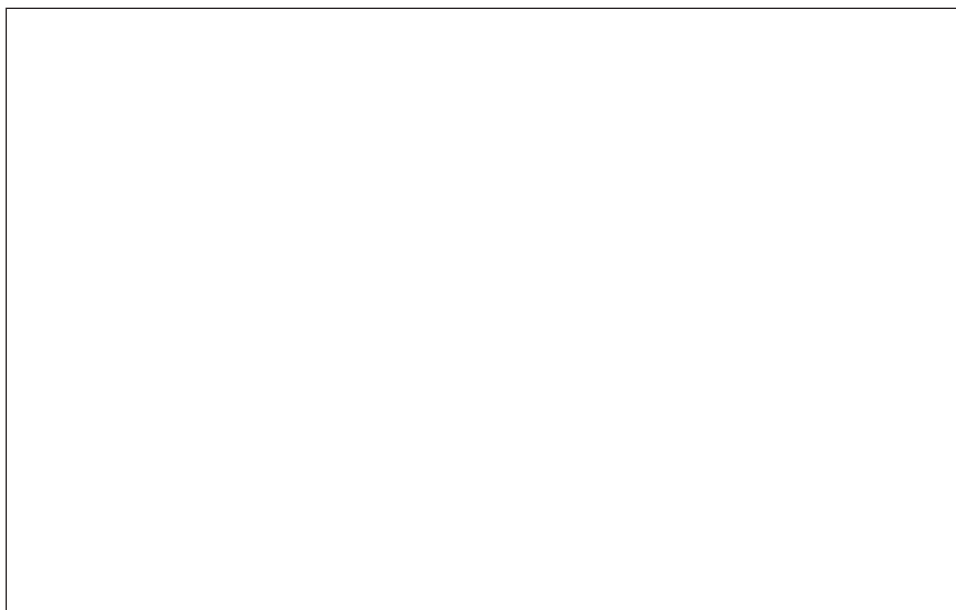

When loaded, the lorry trailer's support leg has a strain of 0.00038 and a change in length of 0.46 mm.

(b) Calculate the original length of the support leg.

3

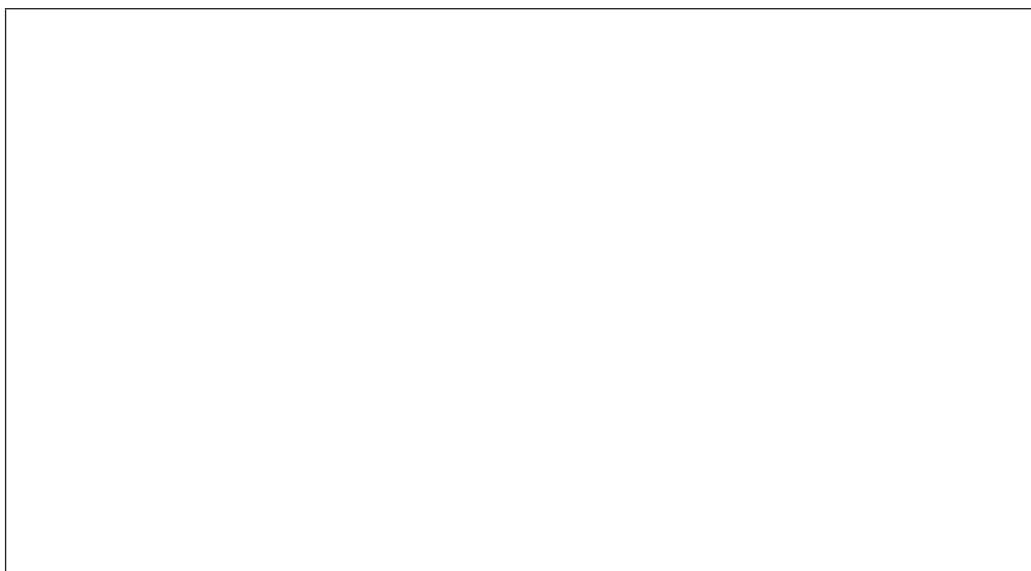

[Turn over



14. (continued)

The temperature inside the trailer is monitored.

Part of the logic circuit used in the temperature monitoring system is shown below.

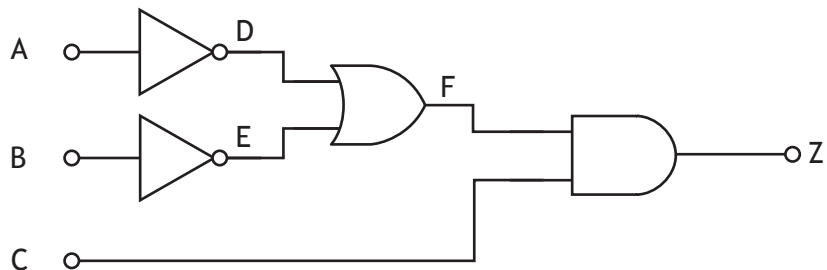

(c) Complete the truth table for the logic circuit shown.

3

A	B	C	D	E	F	Z
0	0	0	1			
0	0	1	1			
0	1	0	1			
0	1	1	1			
1	0	0	0			
1	0	1	0			
1	1	0	0			
1	1	1	0			



[Turn over for next question

DO NOT WRITE ON THIS PAGE



* X 8 2 3 7 5 0 1 2 7 *

15. Pneumatics is used to stamp a logo onto products.

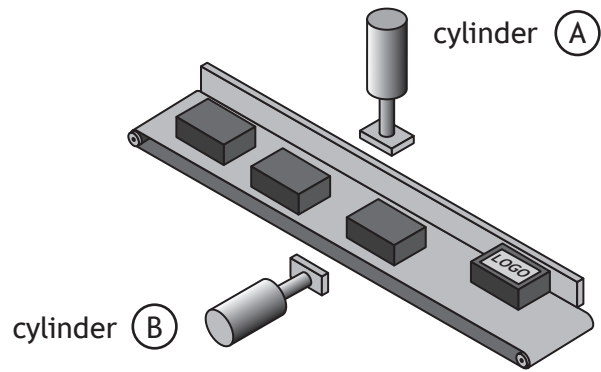

A diagram for a pneumatic circuit that is used to stamp the logo onto the products is shown below.

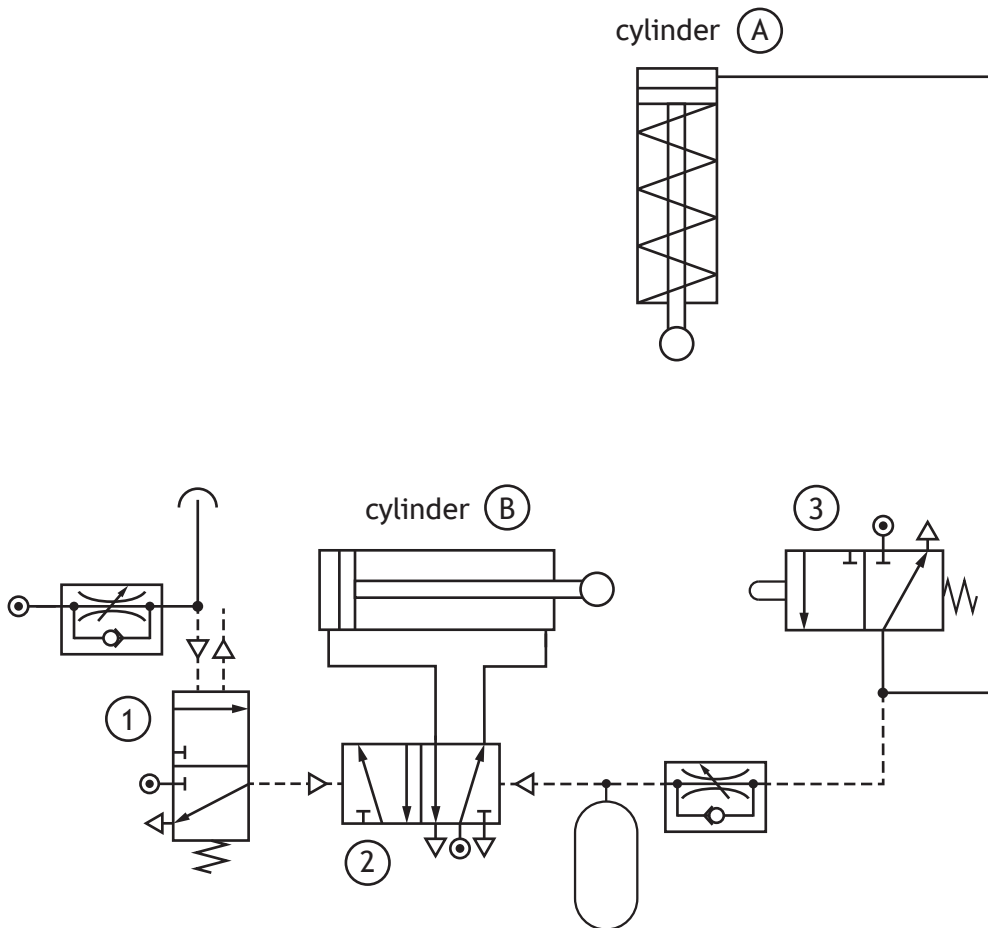

15. (continued)

The piston in the double-acting cylinder is required to outstroke **slowly** and **smoothly**. The speed of the instroke should not be changed.

(c) Describe how this would be achieved.

2

(d) State the type of **motion** a pneumatic piston produces when it outstrokes and then instrokes.

1

[END OF QUESTION PAPER]



MARKS DO NOT
WRITE IN
THIS
MARGIN

ADDITIONAL SPACE FOR ANSWERS



* X 8 2 3 7 5 0 1 3 1 *

ADDITIONAL SPACE FOR ANSWERS

Acknowledgement of copyright

- Question 5 Olivier Tabary/shutterstock.com
- Question 8 mapush/shutterstock.com
- Question 9 Editorial image: GiulianiBruno/shutterstock.com
- Question 10 Petr Malyshev/shutterstock.com
- Question 11 Photology1971/shutterstock.com
- Question 12 Editorial image: marekuliasz/shutterstock.com

