



National 5
Coursework
Assessment Task



National 5 Engineering Science Assignment

Assessment task: Leisure pool complex

Valid for session 2024-25 only.

This is given to centres in strictest confidence. You must keep it in a secure place until it is used.

This edition: January 2025 (version 1.0)

© Scottish Qualifications Authority 2025

Contents

Introduction	1
Instructions for teachers and lecturers	2
Instructions for candidates	5

Introduction

This document contains instructions for teachers, lecturers, and candidates for the National 5 Engineering Science assignment. It must be read in conjunction with the course specification.

There is an additional document that contains the worksheets for this assignment.

This assignment has 50 marks out of a total of 160 marks available for the course assessment.

This is one of two course assessment components. The other component is a question paper.

Whilst this document contains 'instruction for teachers and lecturers' and 'instructions for candidates', everything in the document can be given to candidates.

Instructions for teachers and lecturers

This assignment is valid for the current session only.

Assessment conditions

You must conduct the assignment under a high degree of supervision and control.

This means:

- ◆ all candidates must be within your direct sight
- ◆ candidates must not interact with each other
- ◆ candidates must not have access to email, the internet or mobile phones
- ◆ candidates must complete their work independently – no group work is permitted
- ◆ classroom display materials that might provide assistance must be removed or covered
- ◆ there must be no interruption for learning and teaching
- ◆ candidates must be in a classroom environment

Duration

Candidates have 8 hours to complete the assignment, starting at an appropriate point in the course after all content has been delivered. Once candidates begin their assignment, they must continue in each subsequent class period until the permitted time allocation has been used up.

You have a responsibility to manage candidates' work, distributing it at the beginning and collecting it at the end of each class period, and storing it securely in-between. This activity does not count towards the total time permitted for candidates to complete the assignment.

Resources

This is a closed-book assessment. Candidates must not have access to learning and teaching materials, the internet, notes, exemplar materials, resources on classroom walls or anything similar.

A data booklet containing relevant data and formulae is available on the National 5 Engineering Science subject page on SQA's website. This can be used for the assignment.

Each assessment task includes instructions and details of any equipment or materials required for the assignment. Candidates can also use normal classroom equipment, software and hardware (such as drawing instruments, pneumatics, mechanisms and electronics kit, simulation software, and PCs to run the software) to complete the tasks.

There may be instances where restriction of internet and/or network use is not practical or feasible (for example, a local authority-managed IT network with specific limitations, software that is web-based, or something similar), however, it remains your professional responsibility to make every effort to meet the assessment conditions.

Alteration or adaptation

You must not alter, adapt or modify the assignment in any way – this includes moving the content into a different format. All candidates must undertake the assignment exactly as it has been provided by SQA.

Reasonable assistance

Candidates must progress through each stage of the assignment without your intervention or guidance, having acquired the skills needed earlier in the course.

Once candidates complete the assignment, you must not return it to them for further work. You must not provide feedback to candidates or offer your opinion on the perceived quality or completeness of the assignment response at any stage.

You can provide reasonable assistance to support candidates with the following aspects of their assignment:

- ◆ printing, collating and labelling their evidence to ensure it is in the format specified by SQA
- ◆ ensuring candidates have all the materials and equipment required to complete the assignment
- ◆ understanding the information outlined in these instructions

Artificial Intelligence

This is not permitted. Please see SQA's website for more information, if needed.

Evidence

This assignment will be electronically marked from image (MFI).

You must ensure that all candidate evidence (whether created manually or electronically) is:

- ◆ clear and easy to read (anything handwritten or drawn must be in blue or black permanent ink only)
- ◆ without anything else fixed to the pages (for example, photographs glued in place)
- ◆ labelled at the top to show the task that it refers to
- ◆ labelled at the bottom to show the candidate's Scottish Candidate Number (SCN)
- ◆ compiled in task order with our flyleaf as the front cover
- ◆ printed or presented on A4 paper and secured with a single staple in the top left corner (prints can be single-sided or double-sided, however we prefer double-sided)

Each task must have a hard copy output (printed or hand-written) and each page of the candidate response must note the task number at the top of the page and their Scottish Candidate Number (SCN) at the bottom of the page. This includes where the task asks them to simulate, construct, code, or similar.

Assignment

This assignment contains a number of tasks. Each task details:

- ◆ what the candidate must do (including any specific instructions on how the task must be carried out)
- ◆ how many pages of evidence are expected
- ◆ an anticipated duration

This ensures that candidates understand how to approach the tasks and do not produce too much or spend too long on a single task (whilst there is a time limit for the assignment, there is no page limit or page count).

Candidates can complete the tasks in the order presented or in an order that helps you manage classroom equipment and resources.

You must ensure that candidates are aware of the assessment conditions for the assignment, and that they understand what they should do for each task.

Instructions for candidates

This assignment has 50 marks out of a total of 160 marks available for the course assessment.

This is a closed-book assessment. Your teacher or lecturer lets you know how to carry out the assignment and they will go over the assessment conditions.

The assignment has a number of tasks and for each task you are provided with an engineering science context or situation.

In this assignment, you have to:

- ◆ analyse a problem
- ◆ design a solution to the problem
- ◆ build (simulate or construct) your solution
- ◆ test your solution
- ◆ evaluate your work

Unless otherwise instructed, you should complete tasks in the order presented.

Each task must have a hard copy output (printed or hand-written) and each page of your response must note the task number at the top of the page and your Scottish Candidate Number (SCN) at the bottom of the page. This includes where the task asks you to simulate, construct, code, or similar.'

You have 8 hours to complete the assignment. The time to set up and clear away any equipment you will need, and for any printing that is necessary, does not count towards the 8 hours.

Data sheets – Leisure pool complex

You can use these data sheets and SQA’s National 5 Engineering Science data booklet when completing this assignment. **No other resource material is permitted.**

Electronic symbols

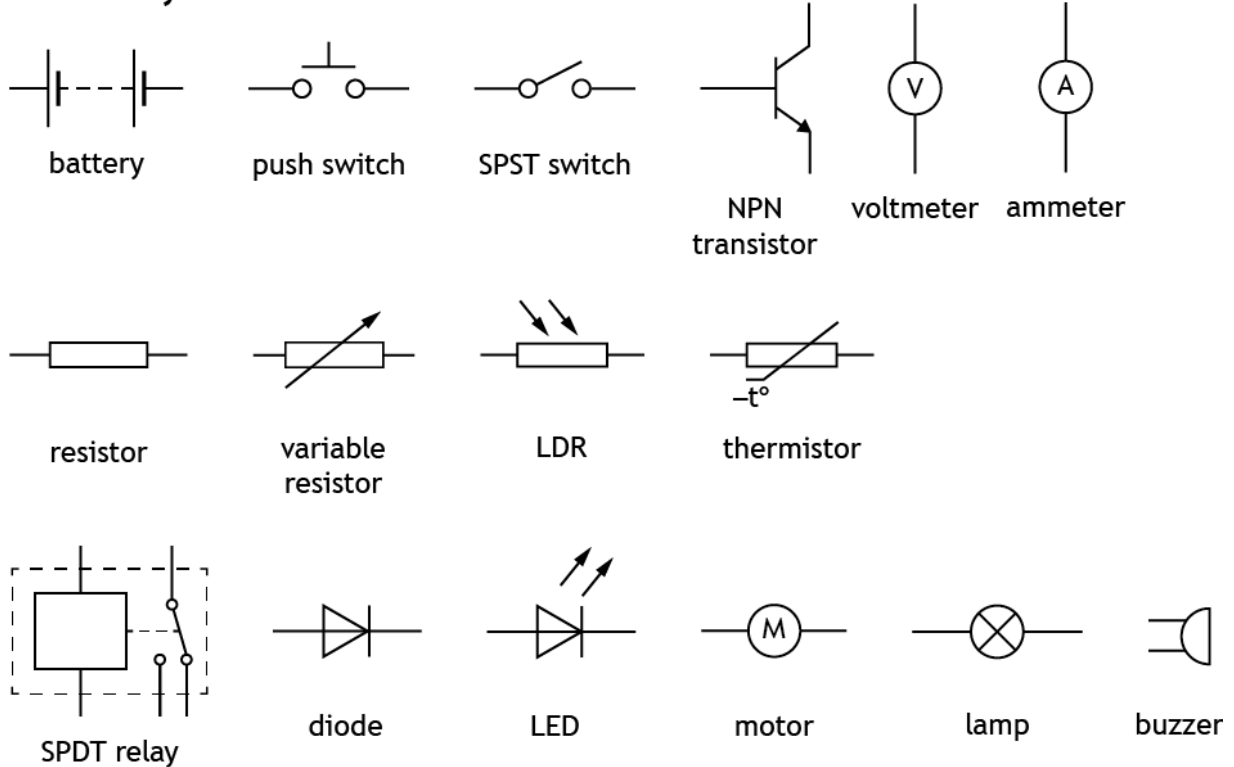

IC pinout diagrams

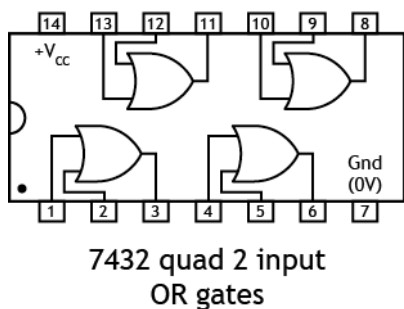
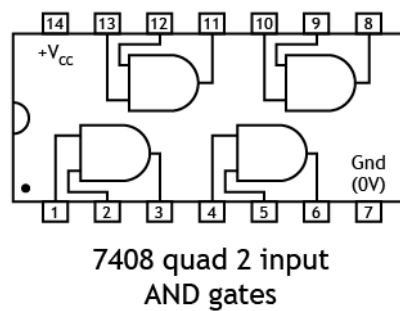
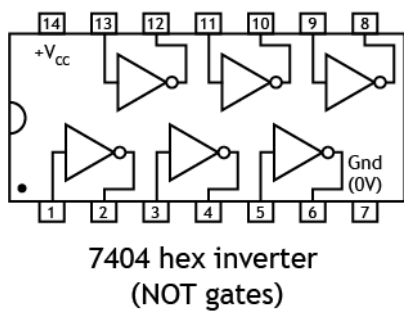

Logic gates

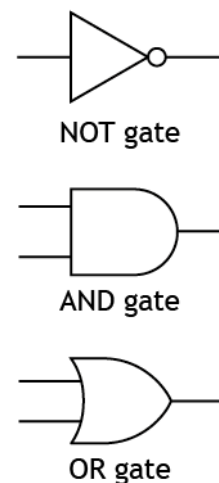

Pneumatic symbols

Actuators



spring return



pilot air



roller



solenoid



lever



diaphragm



roller trip



plunger



push button

Valves

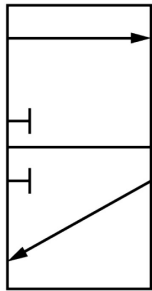

3/2 valve

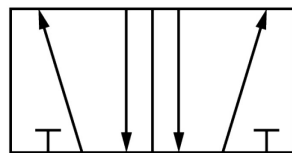

5/2 valve

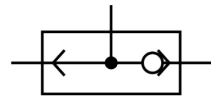

shuttle valve



main air



exhaust

Components and cylinders

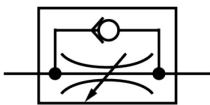

unidirectional restrictor

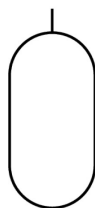

reservoir

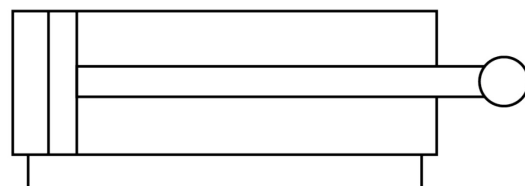

double-acting cylinder

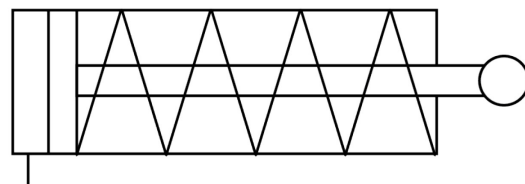

single-acting cylinder

Light Dependent Resistor (LDR) graph for an ORP12 LDR

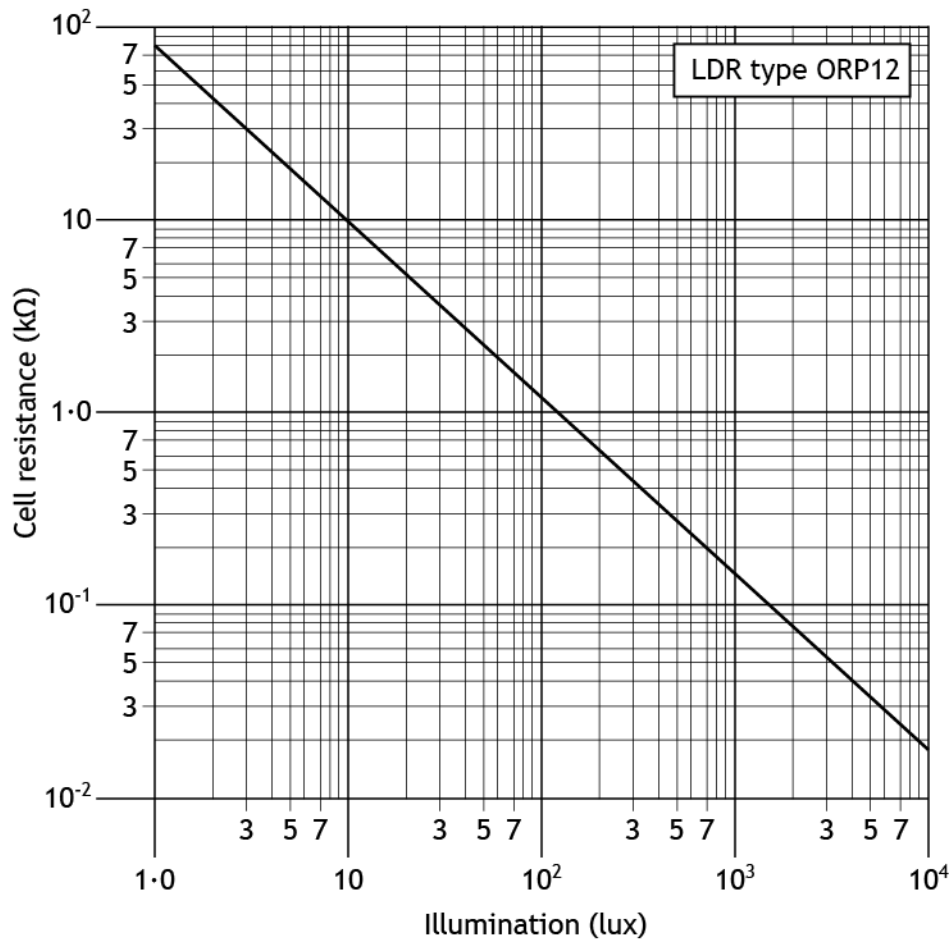

Thermistor graph

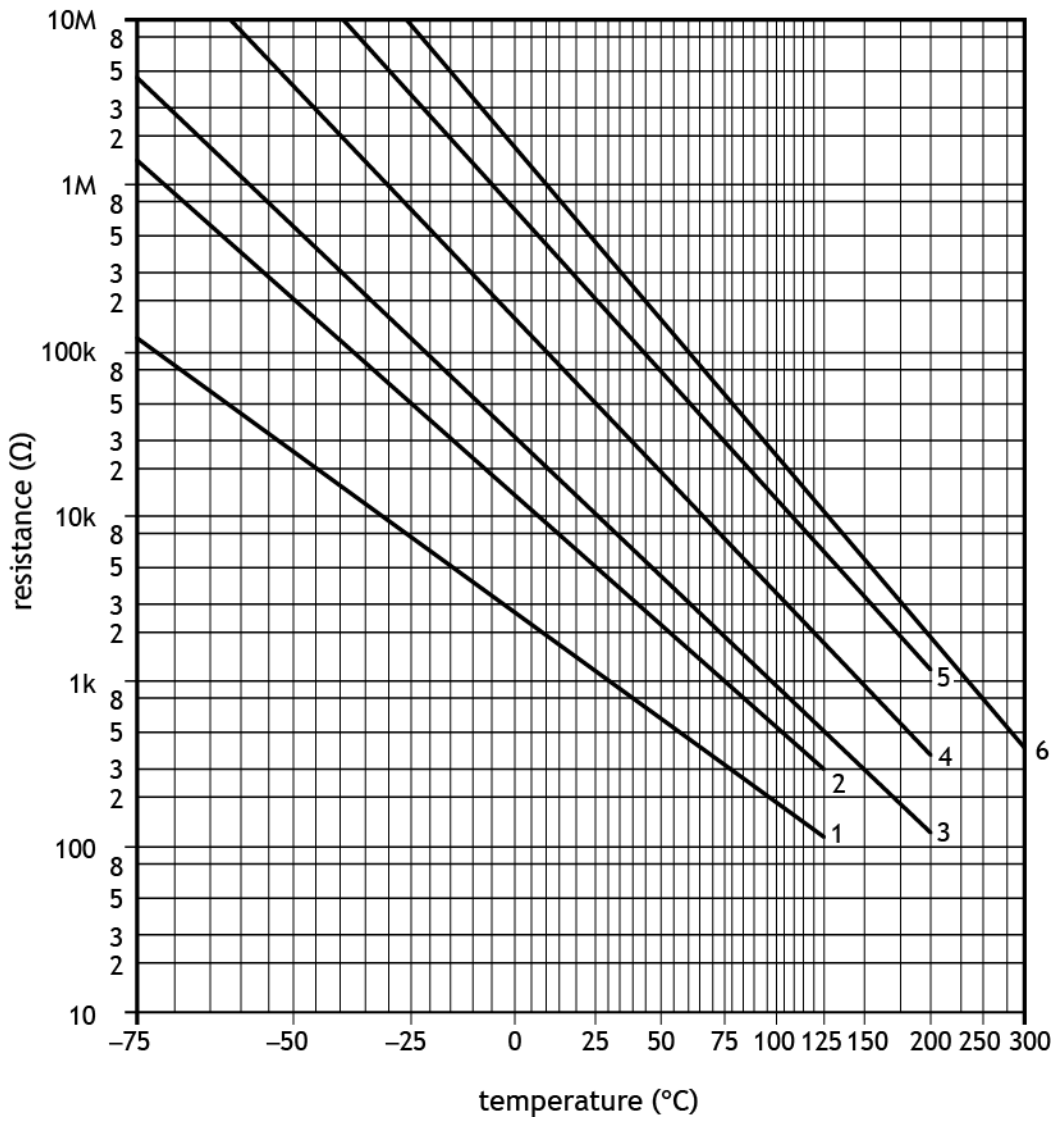

Assignment - Leisure pool complex

A team of engineers is involved in developing a range of systems for a leisure pool complex.

These tasks include developing proposals for the following:

- ◆ Task 1 – pool heating
- ◆ Task 2 – flume
- ◆ Task 3 – motorised cover
- ◆ Task 4 – hot tub
- ◆ Task 5 – pool floor control

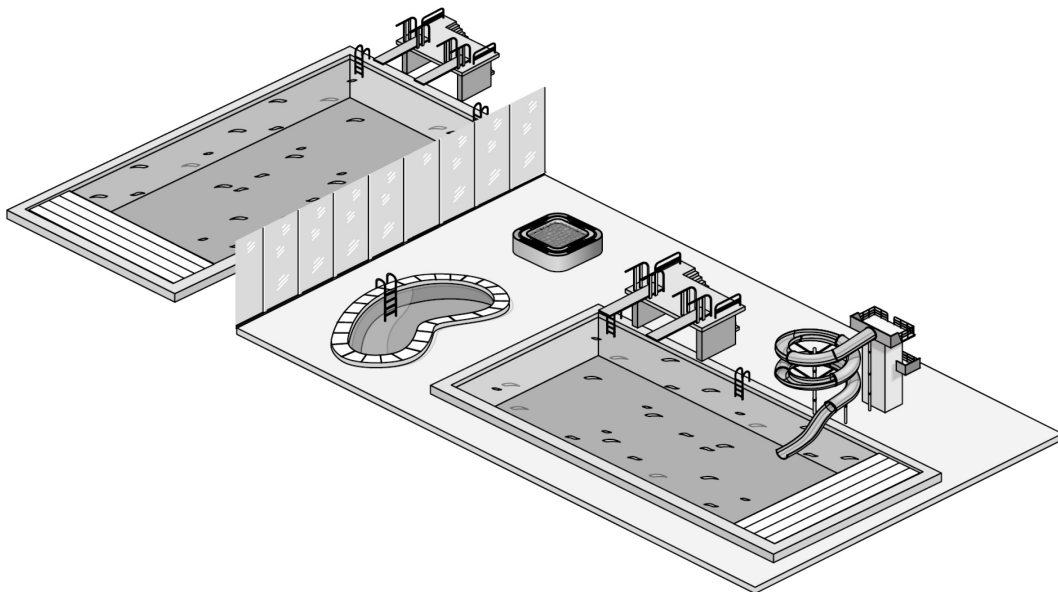

Task 1 – pool heating

- ◆ Notional time: 1 hour 45 minutes
- ◆ Volume: completed on up to four single-sided A4 pages
- ◆ Worksheet: provided for tasks 1a(i), 1a(ii), 1b and 1c
- ◆ **You must not construct or use simulation software to complete task 1b**

The water in the pool complex is heated, to be kept at a constant temperature. The specification for the operation of the pool heating system is given below.

- i The desired temperature of the water is set manually by a pool attendant.
- ii The temperature of the water is constantly monitored. When the temperature falls below the set level, a microcontroller will switch on a heater.
- iii When the temperature of the water rises above the set level, the microcontroller will switch off the heater.

1a (i) Complete the **system diagram** on **worksheet 1a(i)** to meet the specification. You must clearly show the external input and output. **(2 marks)**

(ii) Complete the **sub-system diagram** on **worksheet 1a(ii)** to meet the specification. You must clearly show the external input and output, all sub-systems, the system boundary and interactions between sub-systems. **Any output device requires its own driver.** **(6 marks)**

An input sensing circuit is to be designed to detect the water temperature in the pool. The temperature reading is then sent as a signal to the microcontroller.

1b Complete the circuit diagram on **worksheet 1b**, by designing a suitable **input sensing circuit** that will produce an increase in V_{out} **when it is cold**. Component values are not required.

You must not construct or use simulation software to complete task 1b. **(2 marks)**

1c Complete the test plan on **worksheet 1c**, for the **input sensing circuit** you have designed in **task 1b**, by describing:

- ◆ the expected result from the planned test given in terms of V_{out}
- ◆ a second planned test and its expected result in terms of V_{out} .

(3 marks)

Task 2 – flume

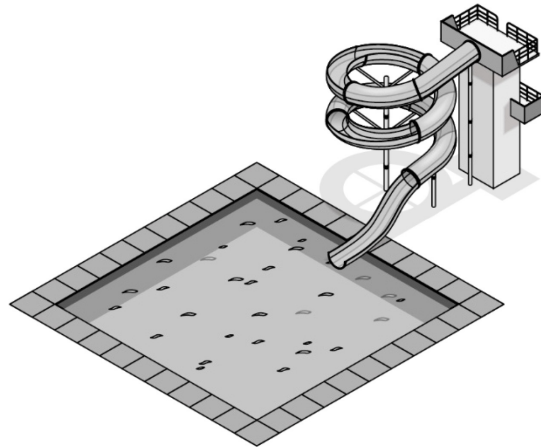

- ◆ Notional time: 2 hour 30 minutes
- ◆ Volume: completed on up to four single-sided A4 pages
- ◆ Worksheet: provided for tasks 2b and 2d

A flume in the leisure pool complex is controlled by a microcontroller-based system.

The connections to the microcontroller are shown in the table below.

Input	Pin	Output
	7	water pump motor
	6	warning LED
	5	buzzer
stop switch	3	
start switch	1	

An electronic engineer has designed a possible solution which is shown on the next page.

Task 2 – flume (continued)

- 2a Simulate the flowchart sequence and electronic circuit **integrated together as shown**.

An alternative microcontroller may be used but the pin numbers must match the connections given.

Produce a hard copy output of your simulation. You must note the task number at the top of the page and your Scottish Candidate Number (SCN) at the bottom of the page.

(5 marks)

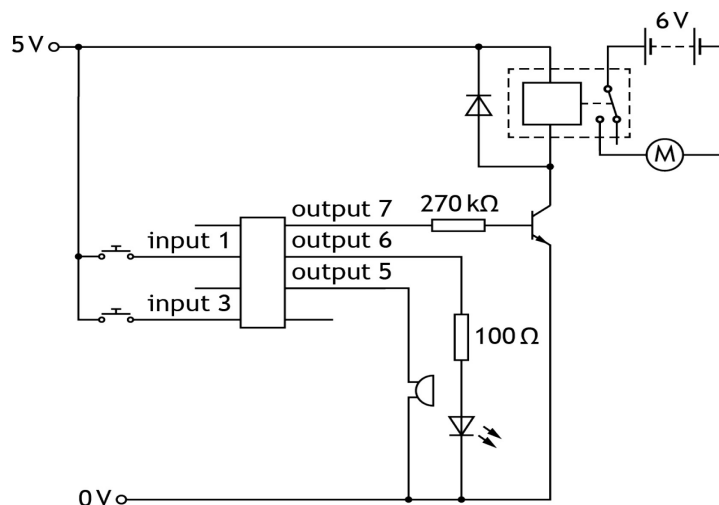
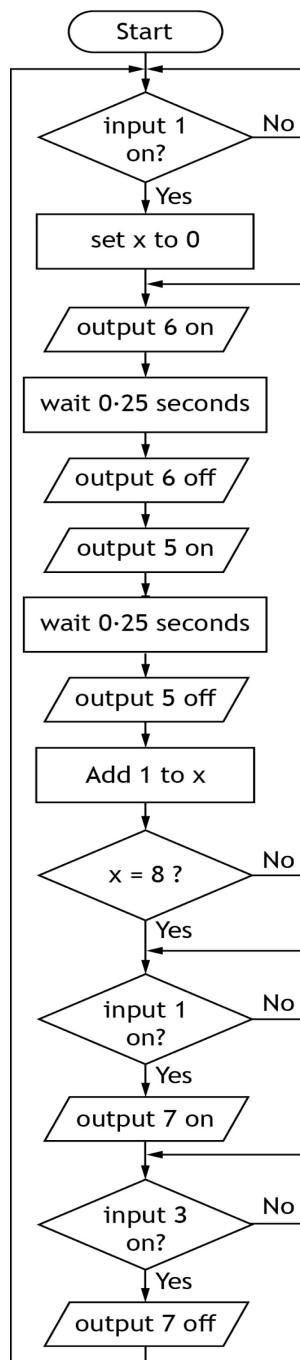

Task 2 – flume (continued)

The flume is to be controlled by the microcontroller to meet the following specification:

- i When an operator presses a start switch, a warning LED and then a buzzer each pulse on and off five times.
- ii When the warning LED and buzzer have finished pulsing, the start switch must be pressed again to turn on a relay, which will turn on a motor to pump water continually through the flume.
- iii When a stop switch is pressed the motor will turn off. The sequence will then repeat.

Errors were found in the flowchart and electronic circuit during testing.

- 2b Complete the testing table on **worksheet 2b**, by carrying out the given planned tests and then describing each initial test result.

Describe your planned amendment, carry out your amendments to the flowchart and/or circuit as necessary to meet the specification and complete each test again.

Describe the result of your re-test before moving onto the next test. (5 marks)

- 2c Your final amended flowchart and electronic circuit should now **meet the specification** given at the start of **task 2b**.

Produce a hard copy output of your simulation. You must note the task number at the top of the page and your Scottish Candidate Number (SCN) at the bottom of the page. **(2 marks)**

- 2d Describe, on **worksheet 2d**, a suitable improvement to the flume control which will **benefit the operator** and justify the reason for this. **(2 marks)**

Task 3 – motorised cover

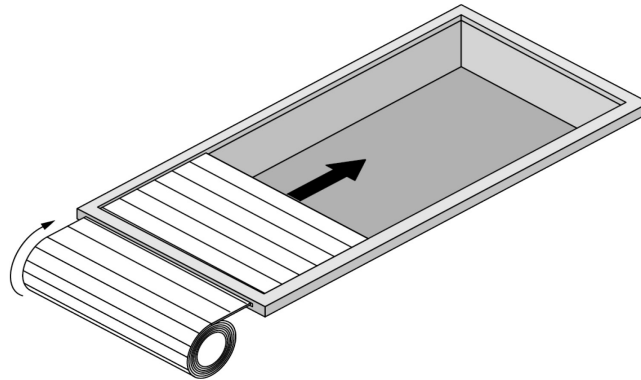

- ◆ Notional time: 1 hour 30 minutes
- ◆ Volume: completed on up to four single-sided A4 pages
- ◆ Worksheet: provided for tasks 3b, 3c and 3d
- ◆ **You must not construct or use simulation software to complete 3d**

The leisure pool complex has an outdoor pool. When not in use, a pool cover is used to retain the heat in the water. A motorised gear train is used to move the cover.

The gear train must meet the following specification.

- i The output gear and input gear must turn in the same direction.
- ii The speed of the output must be reduced to achieve a velocity ratio that is between 5:1 and 10:1.

An initial design for the gear train, along with gear sizes, is shown below.

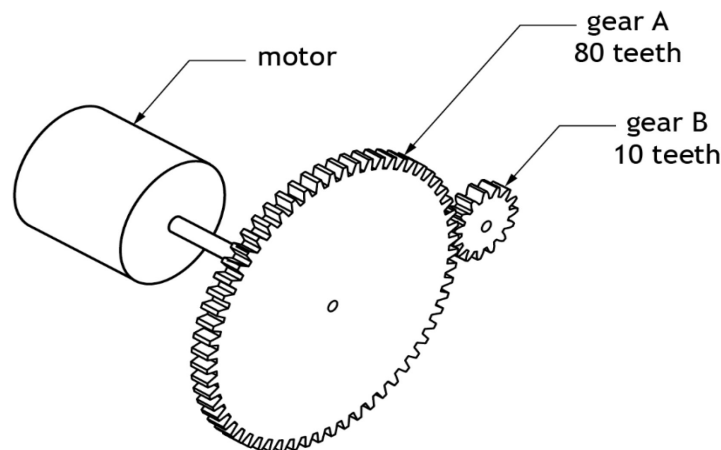

- 3a Simulate or construct the initial design. You must include an **input component** to allow for testing and **label all gear sizes**.

Produce a hard copy output of your simulation or construction. You must note the task number at the top of the page and your Scottish Candidate Number (SCN) at the bottom of the page. **(2 marks)**

Task 3 – motorised cover (continued)

3b Complete the test result table on **worksheet 3b** by:

- ◆ entering the results that you observed for the input and output speeds of the gear system for **task 3a** during simulation or after construction
- ◆ calculating and recording the actual velocity ratio for your input and output speeds. **(3 marks)**

3c Evaluate the initial gear train design against the specification by completing the table on **worksheet 3c**. You should:

- ◆ state if each specification point is met
- ◆ justify each of your decisions. **(2 marks)**

Following a design review, a second drive system is required.

3d Design a **compound gear train**, on **worksheet 3d**, that decreases the speed at the output to achieve a velocity ratio that is between 20:1 and 30:1.

You must label the input gear and include all gear sizes.

You must not construct or use simulation software to complete task 3d.

(2 marks)

Task 4 – hot tub

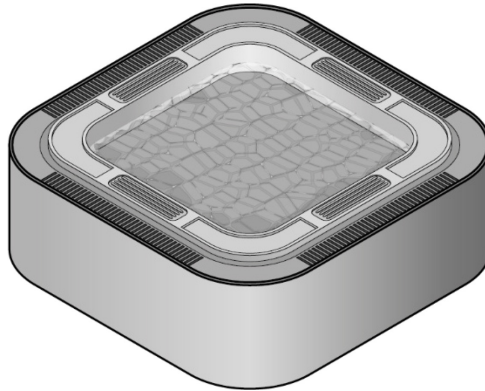

- ◆ Notional time: 1 hour
- ◆ Volume: completed on up to three single-sided A4 pages
- ◆ Worksheet: provided for tasks 4a and 4c
- ◆ **You must not construct or use simulation software to complete task 4a**

A pump motor used in a hot tub turns on when a start button is pressed and the water is not dirty. A maintenance button also allows the pump motor to turn on.

- S - start button
- D - dirty water sensor
- M - maintenance button
- P - pump motor

- 4a Complete the logic diagram on **worksheet 4a** for the following Boolean expression

$$P = (S \cdot \bar{D}) + M$$

You must not construct or use simulation software to complete task 4a.

(3 marks)

- 4b Simulate or construct your logic diagram for **task 4a**. You must include suitable input devices to allow for testing. If constructed, you must clearly label integrated circuit (IC) numbers.

Produce a hard copy output of your simulation or construction. You must note the task number at the top of the page and your Scottish Candidate Number (SCN) at the bottom of the page. **(1 mark)**

- 4c Test your simulated or constructed logic circuit for **task 4b** and complete the truth table on **worksheet 4c**. **(1 mark)**

Task 5 – pool floor control

- ◆ Notional time: 1 hour 15 minutes
- ◆ Volume: completed on up to three single-sided A4 pages
- ◆ Worksheet: provided for tasks 5b and 5c

The main pool floor has to move up and down to change the water depth. This will allow different activities to take place in the pool, for example, swimming lessons for beginners.

A mechanical engineer tested if the floor could be moved using pneumatic components. The circuit below was used in the test.

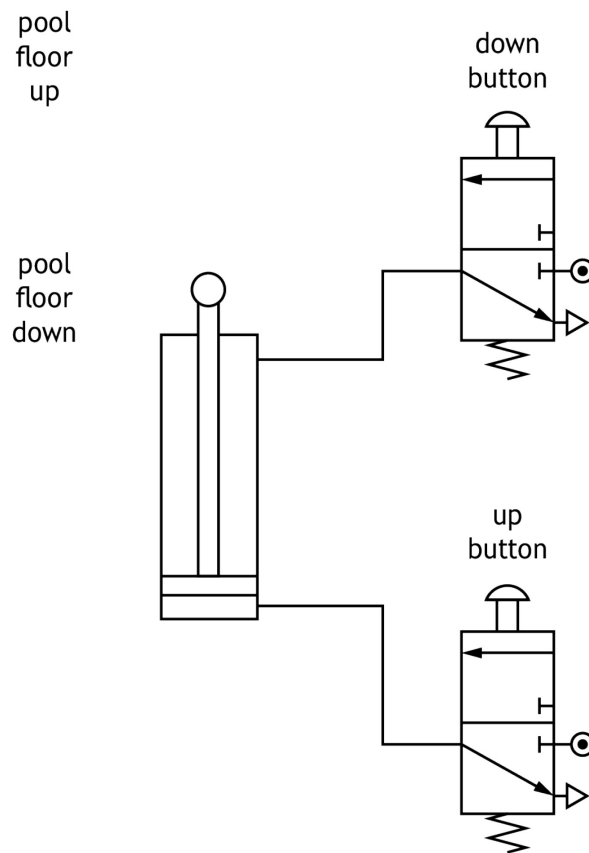

5a Simulate or construct the pneumatic circuit shown.

You can use alternative actuators on the 3/2 valves.

Produce a hard copy output of your simulation or construction. You must note the task number at the top of the page and your Scottish Candidate Number (SCN) at the bottom of the page.

(2 marks)

Task 5 – pool floor control (continued)

After confirming that pneumatics could be used to move the pool floor, the following specification was written.

- i When an electrical actuator on a 3/2 valve receives a signal, a pneumatic time delay occurs.
- ii After the time delay, a signal is sent to a 5/2 valve causing the piston in a double-acting cylinder to **outstroke slowly and smoothly** to raise the floor.
- iii When a manual pneumatic actuator on a second 3/2 valve is activated, a signal is sent to the 5/2 valve causing the piston in the double-acting cylinder to instroke and lower the floor.

5b Complete the design for the pneumatic circuit on **worksheet 5b** to meet the specification.

You must identify each component, valve and actuator and you must indicate the direction of the piston outstroke. You must show connections between all components and valves.

You can simplify components, for example: a 5/2 valve could be drawn as shown below. (5 marks)

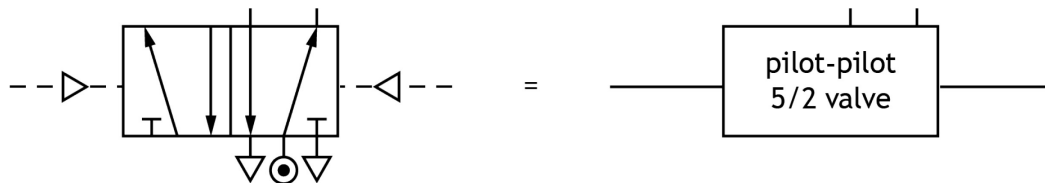

5c Describe, on **worksheet 5c**, a suitable pneumatic modification to the circuit specified in **task 5b** that would make the operation of the pool floor safer and justify the reason for this. (2 marks)

[END OF ASSIGNMENT]

Copyright acknowledgements

Administrative information

Published: January 2025 (version 1.0)

History of changes

Version	Description of change	Date

Security and confidentiality

This document can be used by practitioners in SQA approved centres for the assessment of National Courses and not for any other purpose.

This document may only be downloaded from SQA's designated secure website by authorised personnel.

© Scottish Qualifications Authority 2025