



FOR OFFICIAL USE

--	--	--	--	--	--

National
Qualifications
2016

Mark

--

X735/75/01

Graphic Communication

TUESDAY, 10 MAY

1:00 PM – 2:30 PM



* X 7 3 5 7 5 0 1 *

Fill in these boxes and read what is printed below.

Full name of centre

--

Town

--

Forename(s)

--

Surname

--

Number of seat

--

Date of birth

Day

--	--

Month

--	--

Year

--	--

Scottish candidate number

--	--	--	--	--	--	--	--	--	--

Total marks — 60

Attempt ALL questions.

All dimensions are in mm.

All technical sketches and drawings use third angle projection.

You may use rulers, compasses or trammels for measuring.

In all questions you may use sketches and annotations to support your answer if you wish.

Write your answers clearly in the spaces provided in this booklet. Additional space for answers is provided at the end of this booklet. If you use this space you must clearly identify the question number you are attempting.

Use **blue** or **black** ink.

Before leaving the examination room you must give this booklet to the Invigilator; if you do not, you may lose all the marks for this paper.



* X 7 3 5 7 5 0 1 0 1 *



1. A company, WAVE, are promoting a new wireless speaker using a webpage. A graphic designer has produced a series of thumbnails for the design of the webpage.

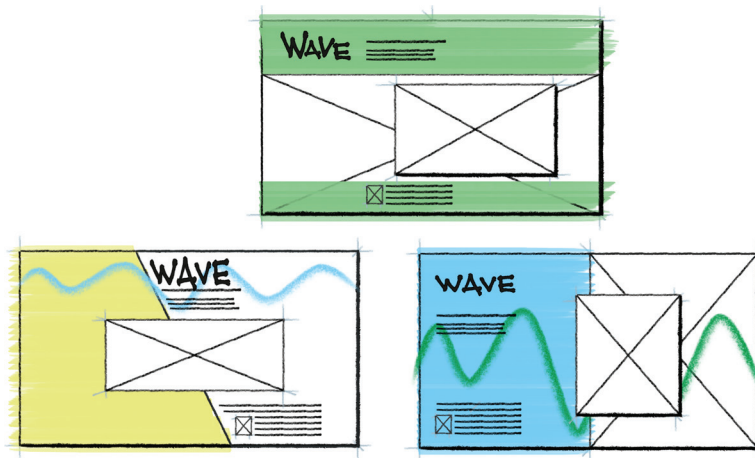

- (a) State **two** reasons why thumbnail sketches would be produced during the preliminary stages.

2



1. (continued)

The graphic designer selected one of the thumbnails and decided to use DTP software to develop the initial idea. The thumbnail is shown below with the designer's annotations showing suggested changes.

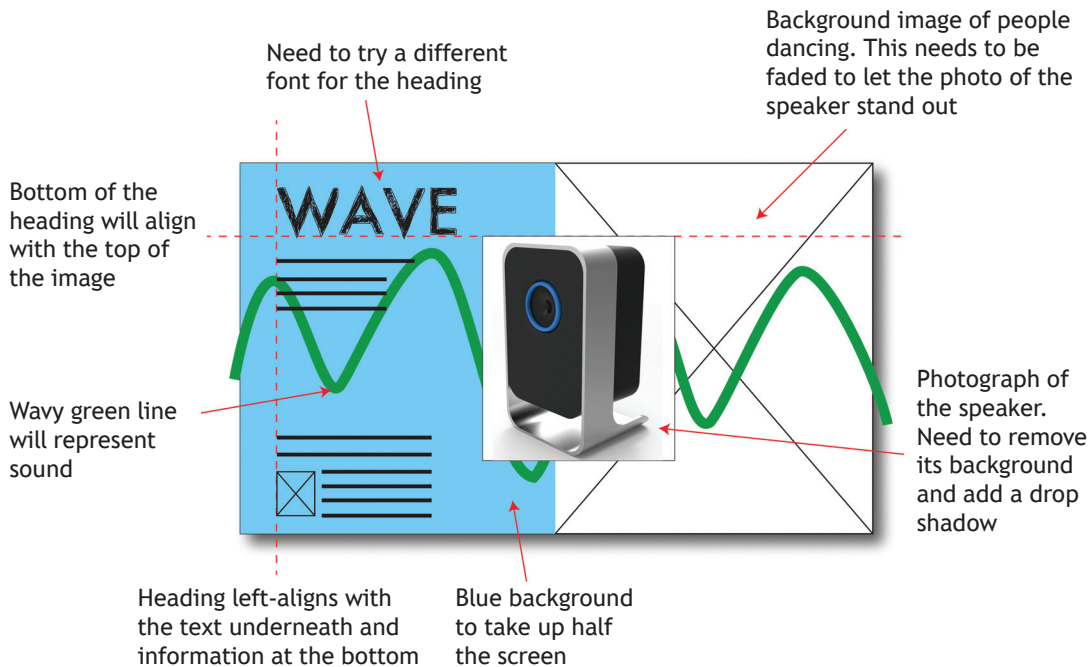

The graphic designer used the above thumbnail annotations to develop the design using DTP software.

(b) Explain **three** advantages to the graphic designer of using DTP software to produce a graphic layout.

3

[Turn over



1. (continued)

The final design for the webpage is shown below.



(c) Describe the effect to the webpage of using the green lines.

2

(d) Explain how the graphic designer has used the following design elements and principles to create visual impact in the final design.

(i) Depth

2



1. (d) (continued)

(ii) Dominance

2

(iii) Alignment

2

(e) Transparency has been applied to the image of the people dancing in the webpage.

Describe why the graphic designer has used the desktop publishing technique “transparency” on this image.

1

(f) Describe how the desktop publishing technique “bleed” has been used in the webpage design.

1

The company, WAVE, originally planned on using posters to promote their product.

(g) Describe the **positive** impact to the environment of using a webpage rather than printed posters to promote the product.

2



* X 7 3 5 7 5 0 1 0 5 *

2. ECHO is a new fragrance created by “Common Scents”. The bottle and packaging have been designed to reflect the product name.

The centre ‘O’ring consists of two interlocking parts that secure the bottle in the packaging.

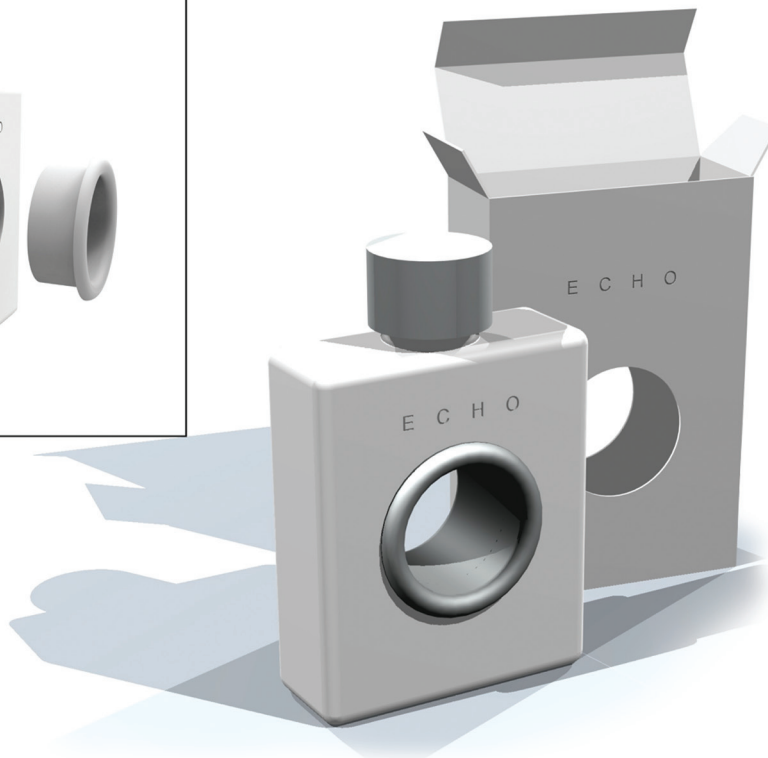

The product will be mass produced and sold globally. The company wish to minimise the product’s impact on the environment.

- (a) Describe **two** ways the designer can reduce the impact the packaging has on the environment.

2



2. (continued)

The packaging for the bottle is to be manufactured from a single sheet of card. A surface development of the packaging is shown below.

The CAD technician has been asked to identify the positioning of key features that are to be cut out.

- (b) Indicate on the surface development, below, where the text “ECHO” will be cut out.

1

You should use the CAD illustration provided on the previous page.
Use “E” to indicate the position of the text.

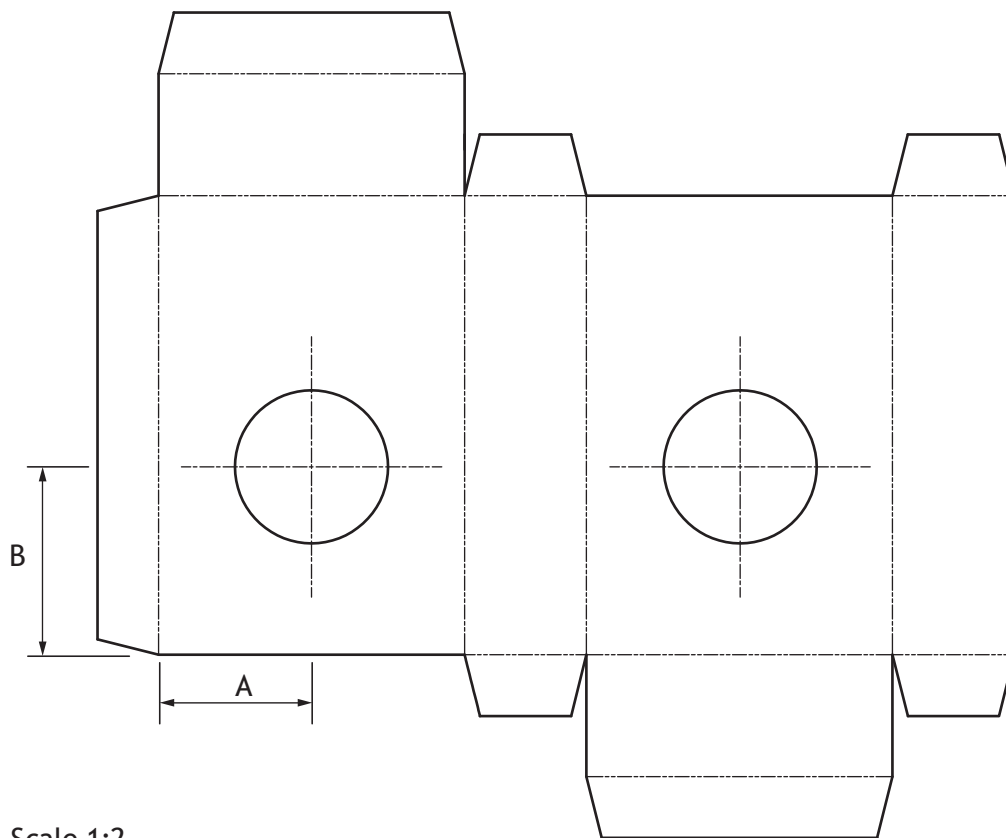

Scale 1:2

- (c) Calculate, using the scale 1:2, measurements A and B (indicated on the above development).

Use a ruler to measure.

(i) Measurement A _____ mm

1

(ii) Measurement B _____ mm

1



2. (continued)

- (d) State **one** factor that would influence the choice of scale in a drawing. 1

The CAD technician is unsure which dimensioning technique to use and has applied two different methods shown in the assembled orthographic views provided in the **Supplementary Sheets for use with question 2(e)**.

- (e) (i) State the type of dimensioning used for the elevation. 1

- (ii) State the type of dimensioning used for the plan. 1



* X 7 3 5 7 5 0 1 0 8 *

[Turn over for next question

DO NOT WRITE ON THIS PAGE



* X 7 3 5 7 5 0 1 0 9 *

2. (continued)

Orthographic Sectional views were produced to aid manufacture.

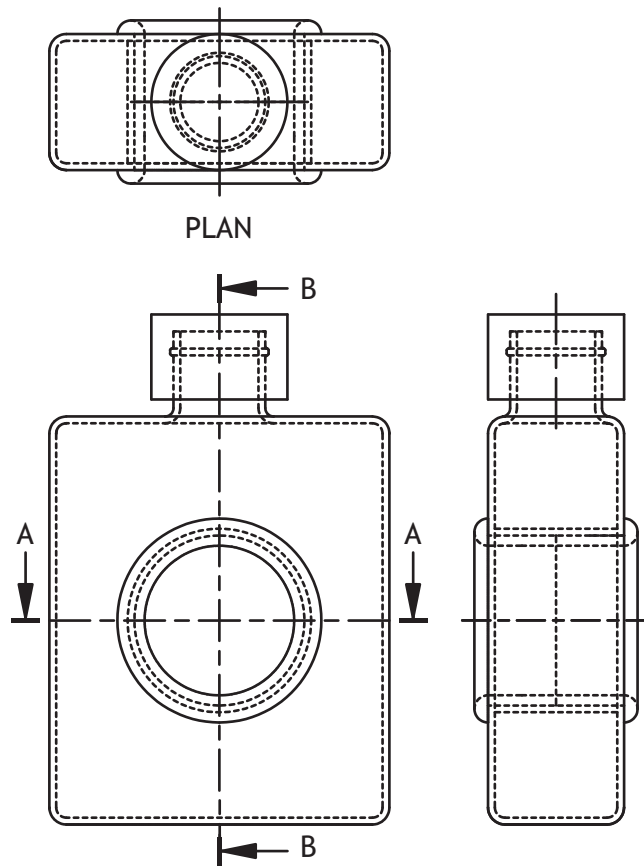

(f) Indicate the correct sectional plan A-A, indicated in the drawing above, by ticking a box below.

1

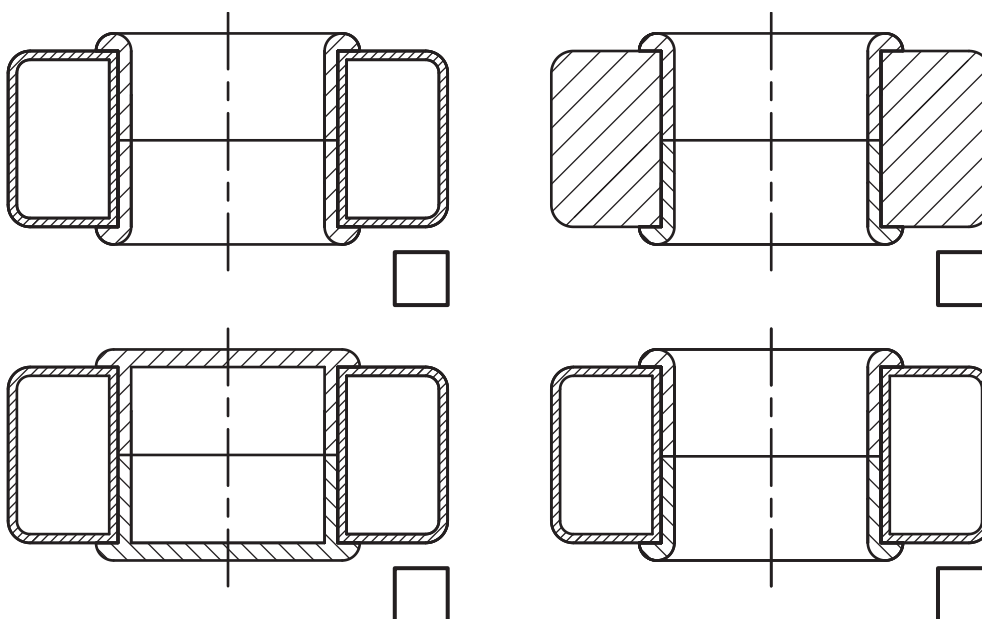

2. (continued)

(g) Indicate the correct sectional end elevation B-B, indicated in the drawing opposite, by ticking a box below.

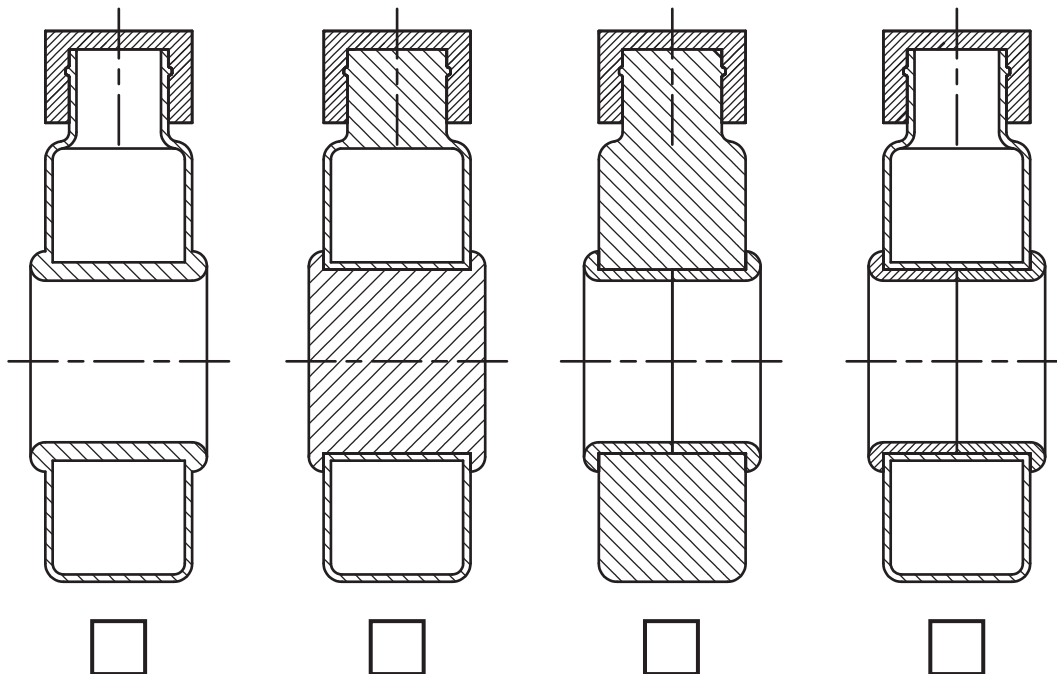

[Turn over



* X 7 3 5 7 5 0 1 1 1 *

3. "Cone" is a portable container for storing earphones and other cable accessories.

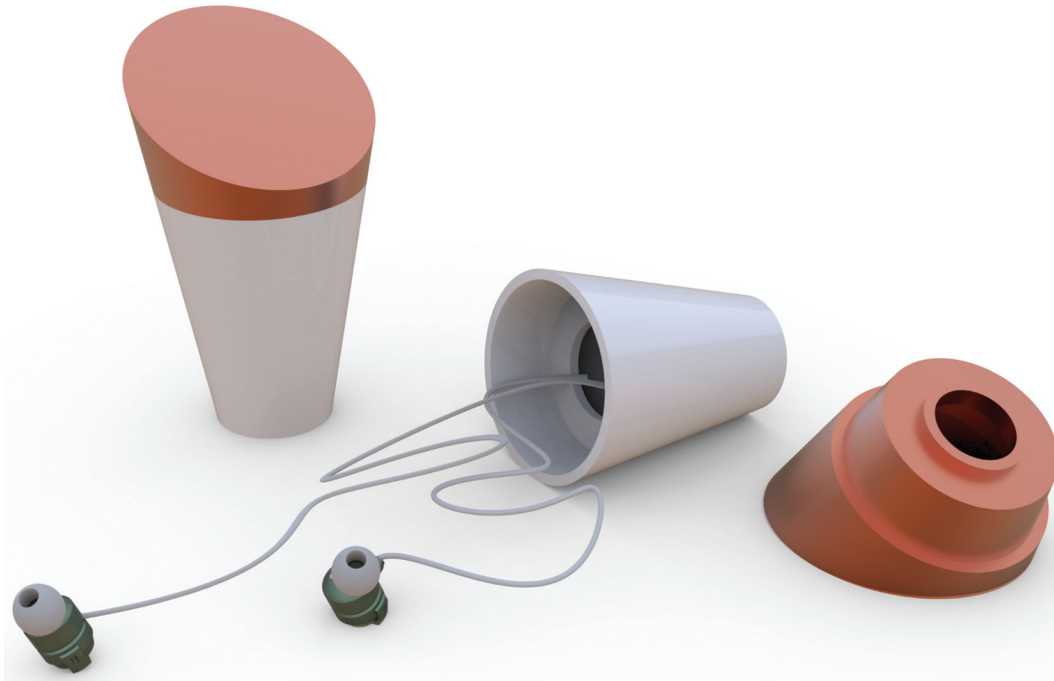

3. (continued)

The lid was modelled using 3D CAD modelling software.

- (a) Describe, with reference to correct dimensions and 3D CAD modelling techniques, how the lid can be produced.

6

You must use the drawing provided in the Supplementary Sheets for use with question 3(a).

You may use sketches to support your answer.

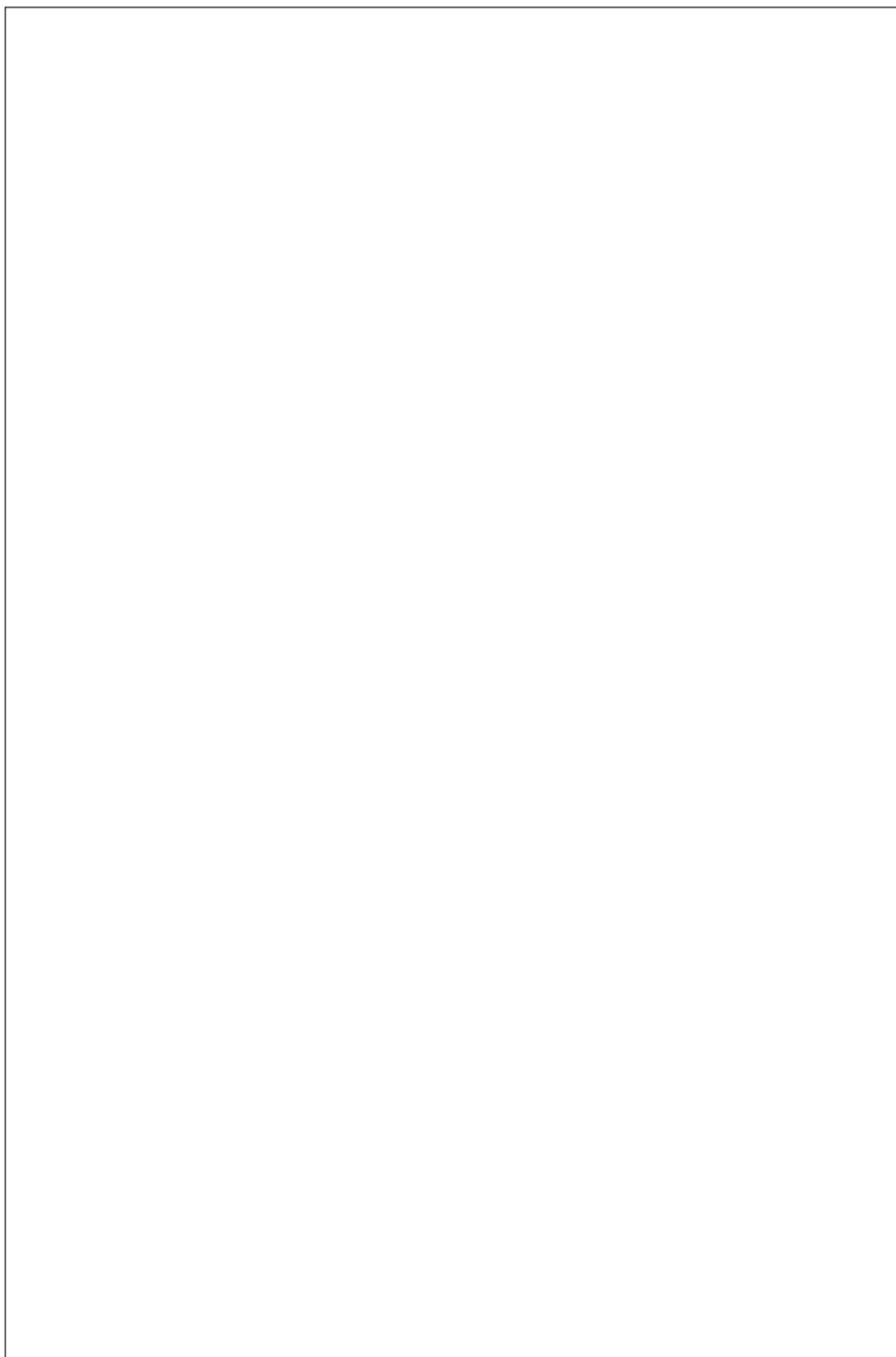

* X 7 3 5 7 5 0 1 1 3 *

3. (continued)

The CAD technician was asked to generate the true shape of the sloping surface “X-X” as indicated in the orthographic drawing.

- (b) Identify the correct true shape of the sloping surface “X-X” by ticking a box below.

1

You must use the drawing provided in the Supplementary Sheets for use with question 3(b).

You may use a ruler, compass or trammel for measuring.

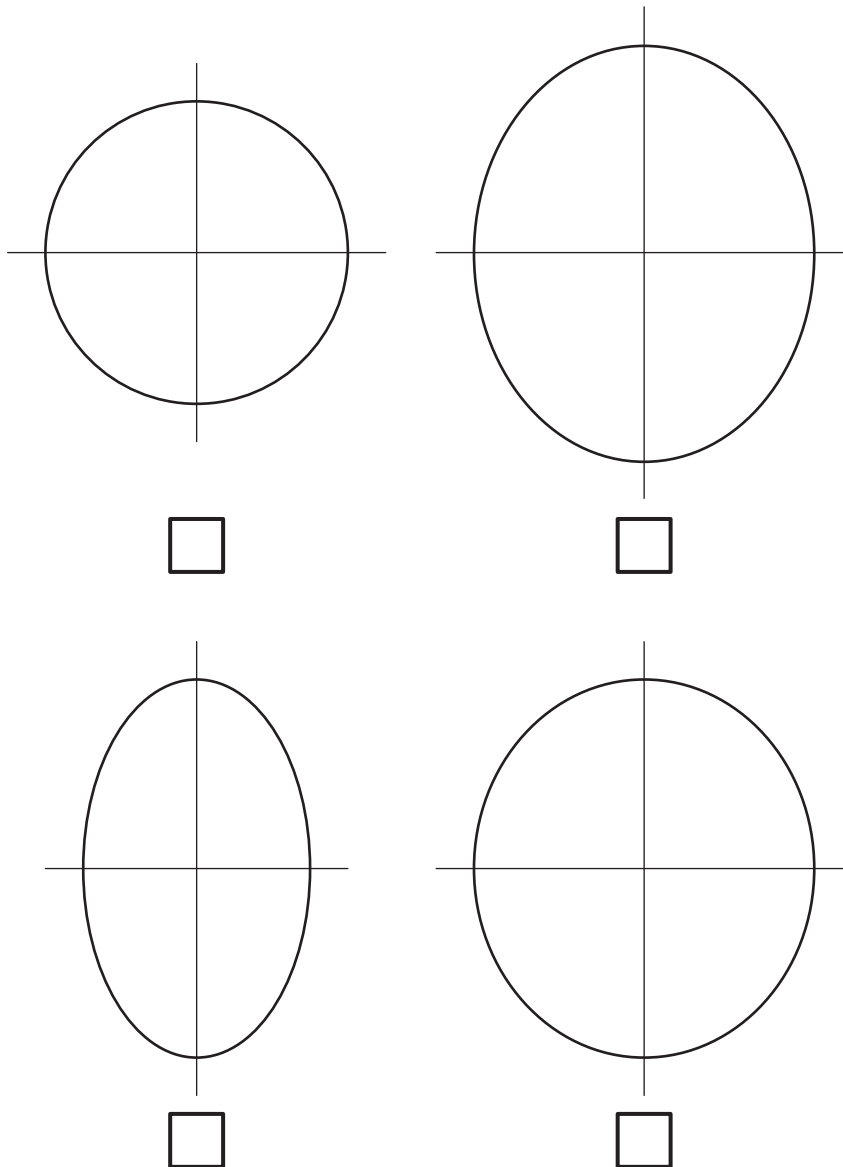

3. (continued)

The designer added details to the sloping surface of the lid. The detail consisted of four identical shapes positioned around the centre and raised from the surface.

The initial sketch of one of these shapes is shown in **bold black**. The additional shapes in red were then created using 2D CAD editing commands.

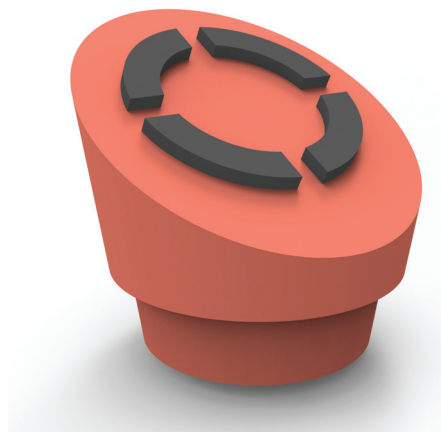
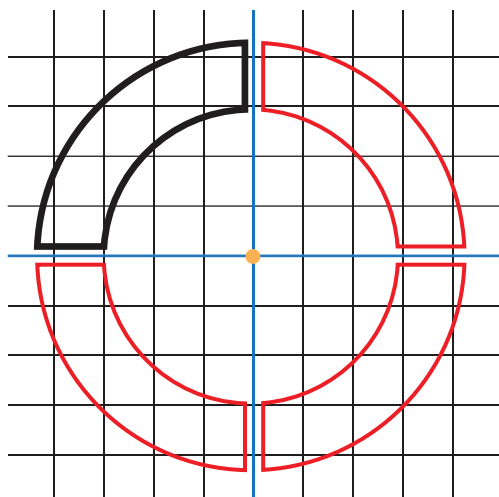

- (c) Describe, with reference to **2D CAD editing** commands, how the CAD technician has repeated the shape without having to redraw each shape again.

2

You may use sketches to support your answer.

3. (continued)

The CAD technician extruded the detail on the sloping surface of the lid but also wanted this feature to be shelled along with the other features.

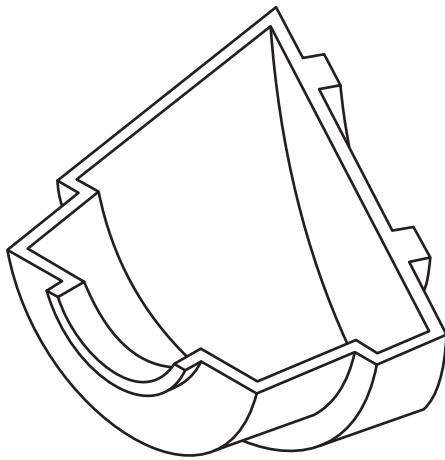

Before

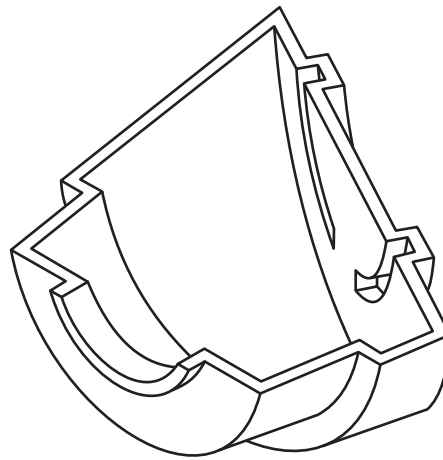

After

- (d) Explain how the model could be updated to include the additional shell details. 2



* X 7 3 5 7 5 0 1 1 6 *

3. (continued)

The lid and main body of “Cone” were assembled using 3D CAD modelling software.

- (e) Indicate by **shading** the relevant **surfaces** and state using 3D CAD terms how you would insert the lid into the body.

3

Stage one has been shaded for you.

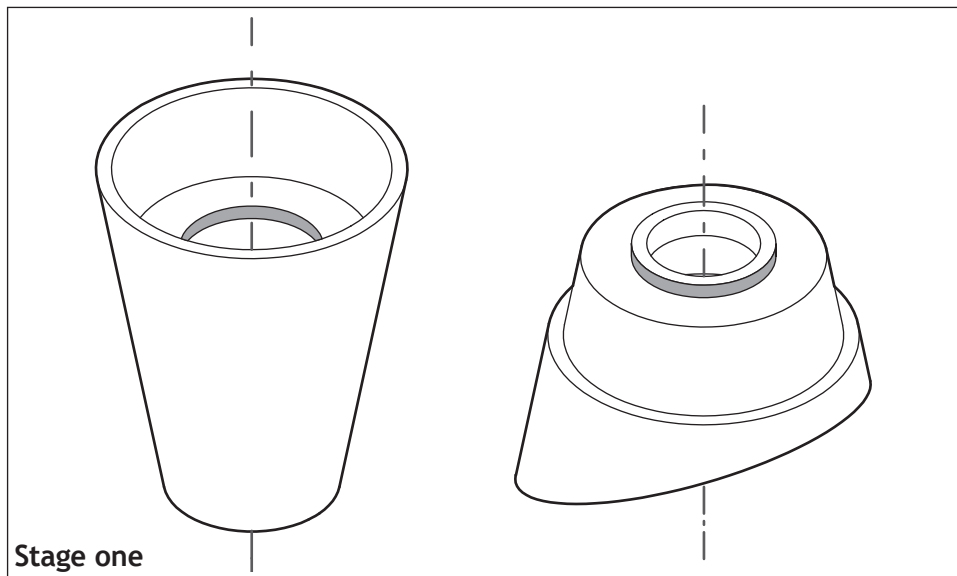

Constraint used

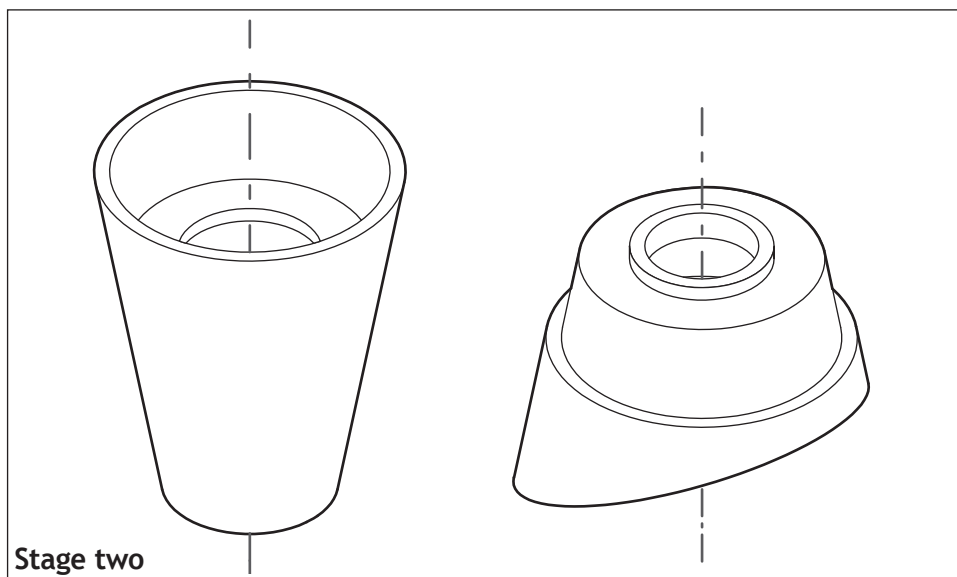

Constraint used



* X 7 3 5 7 5 0 1 1 7 *

4. Terra Leisure group have designed a range of eco lodges as part of their new holiday park accommodation. The graphic designer produced a flyer detailing the range. The final design is shown below.



Graphics for a construction project fall into 3 main types: *Preliminary, Production and Promotional*.

- (a) (i) State, from the list given above, the **type** of graphic shown above. 1

- (ii) Describe the purpose of this type of graphic. 1

A 3D rendered illustration of the lodge was required for the flyer. Terra Leisure had this illustration produced by a CAD technician in another country.

- (b) Describe **two** advantages that **remote working** offers to Terra Leisure. 2



4. (continued)

A plan of the holiday park was drawn up as part of the construction project.

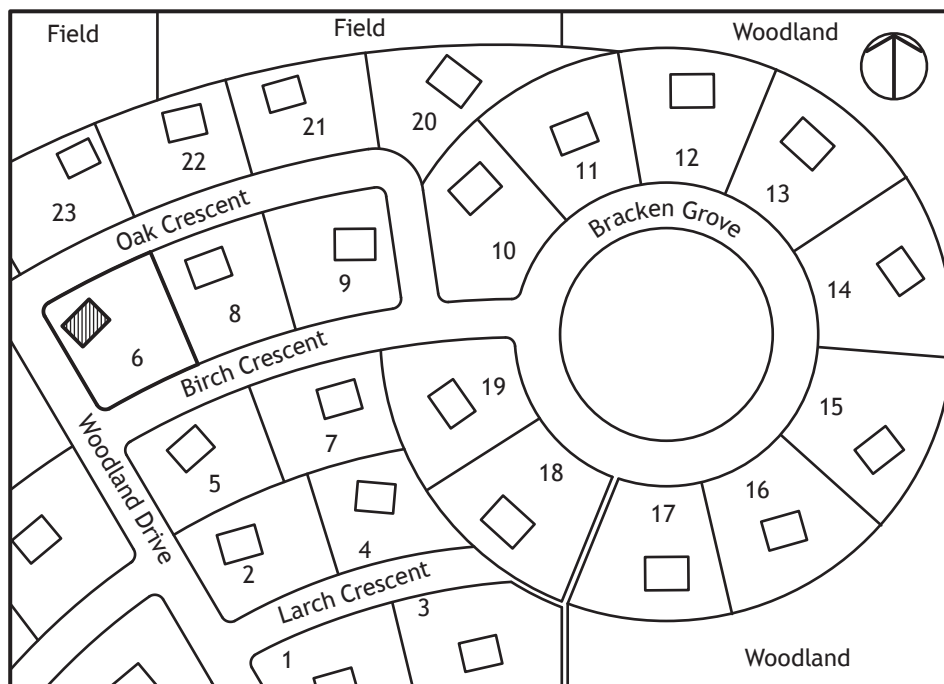

(c) (i) State the name of the plan type shown. 1

(ii) State a scale that is commonly used for this plan type. 1

[Turn over



* X 7 3 5 7 5 0 1 1 9 *

4. (continued)

The CAD technician produced pictorial line drawings of the front and rear of the lodge.

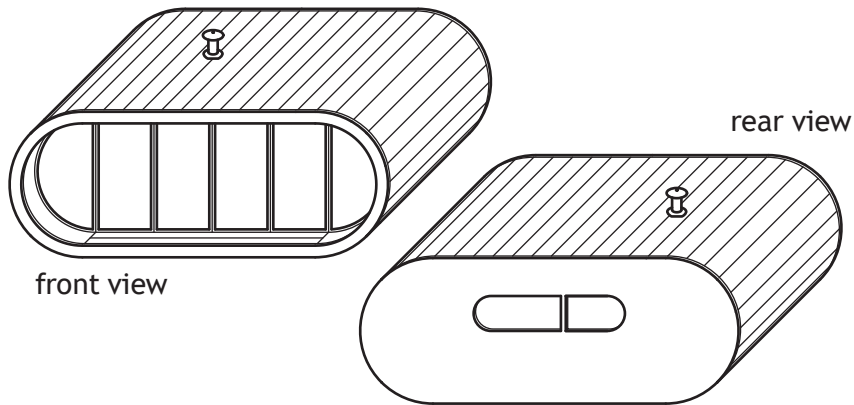

(d) (i) State the type of pictorial line drawings shown above. 1

(ii) Explain why this type of view would be used. 1



* X 7 3 5 7 5 0 1 2 0 *

4. (continued)

The CAD technician produced a site plan as part of the construction project and wishes to calculate the position of the lodge in relation to the plot boundary. The front of the lodge faces onto Birch Crescent.

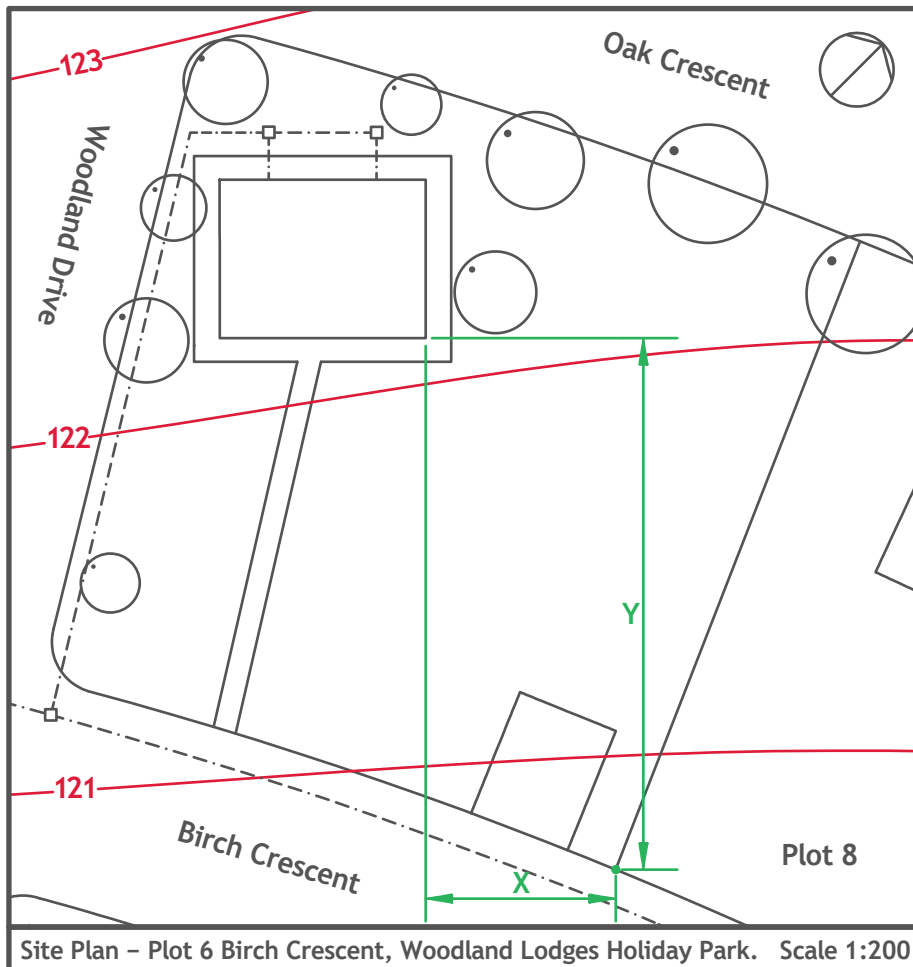

(e) Calculate, using the scale shown, the following distances.

(i) Distance X _____ Metres 1

(ii) Distance Y _____ Metres 1

(f) State the name of the features drawn in red on the site plan. 1

(g) State the direction that the front of the lodge faces. 1



* X 7 3 5 7 5 0 1 2 1 *



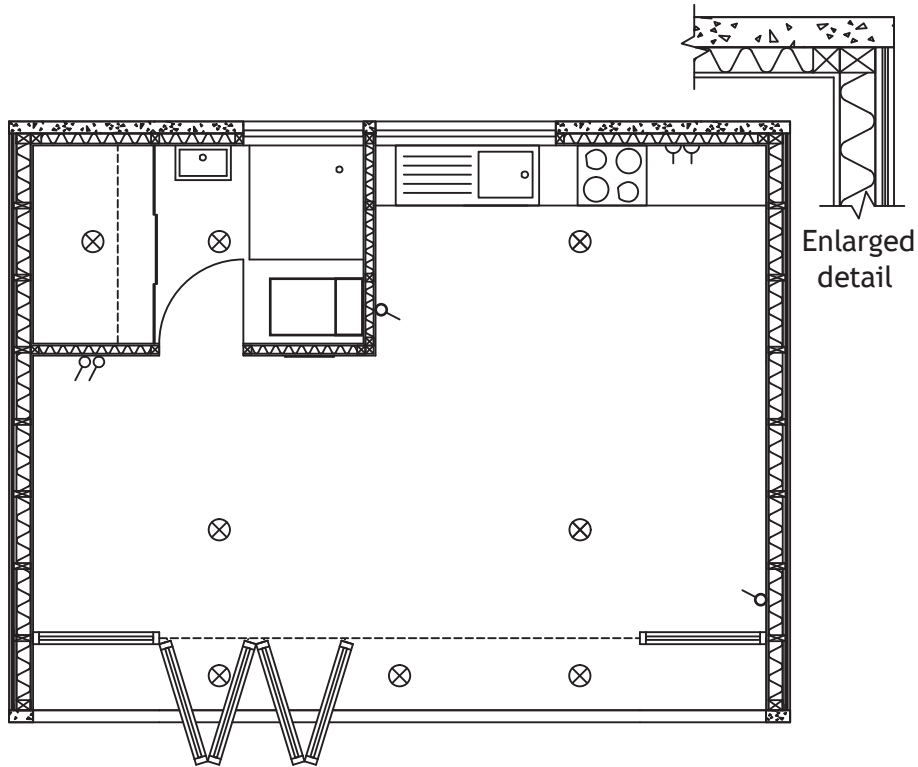

4. (continued)

The CAD technician produced a floor plan and enlarged detail of the lodge.

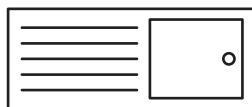

(h) State the names of the building drawing symbols shown below.

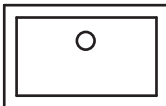
4

	_____		_____
	_____		_____



4. (continued)

In addition to their standard lodge, “Terra”, offer a premium range of lodges. These use modular components that allow the owners to create their own unique layout.

Elevations for three different lodge designs, A, B, and C are shown below.

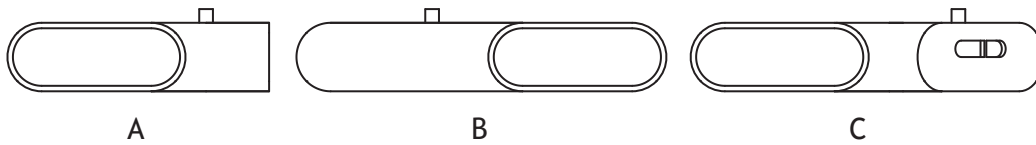

- (i) Identify the correct pictorial view for each of the elevations above by marking **A**, **B** or **C** in the appropriate box below. You should select only one pictorial for each of the elevations.

3

There is only one correct answer for each elevation.

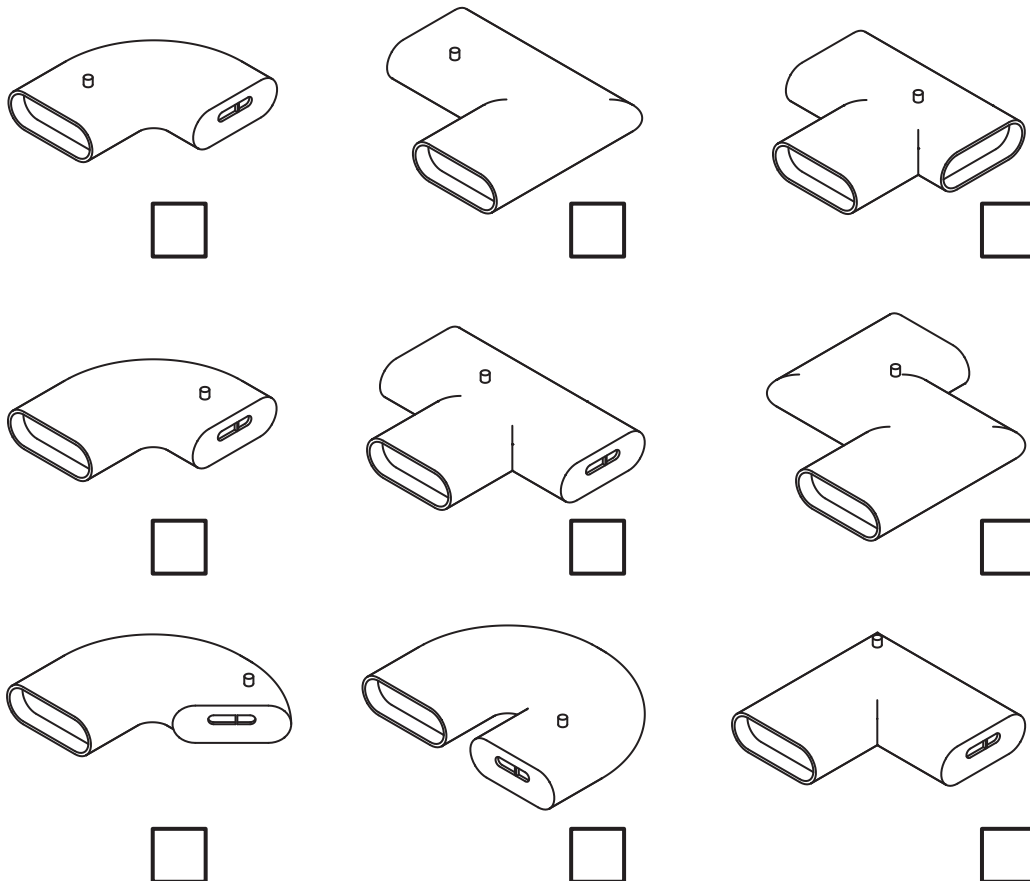

[END OF QUESTION PAPER]



MARKS

DO NOT
WRITE IN
THIS
MARGIN

ADDITIONAL SPACE FOR ANSWERS



* X 7 3 5 7 5 0 1 2 4 *

MARKS

DO NOT
WRITE IN
THIS
MARGIN

ADDITIONAL SPACE FOR ANSWERS



* X 7 3 5 7 5 0 1 2 5 *

[BLANK PAGE]

DO NOT WRITE ON THIS PAGE



* X 7 3 5 7 5 0 1 2 6 *

[BLANK PAGE]

DO NOT WRITE ON THIS PAGE



* X 7 3 5 7 5 0 1 2 7 *

[BLANK PAGE]

DO NOT WRITE ON THIS PAGE



* X 7 3 5 7 5 0 1 2 8 *



National
Qualifications
2016

X735/75/11

**Graphic Communication
Supplementary Sheets**

TUESDAY, 10 MAY
1:00 PM – 2:30 PM

Supplementary Sheets for use with Questions 2 and 3.



* X 7 3 5 7 5 1 1 *

Supplementary Sheet for use with Question 2 (e)

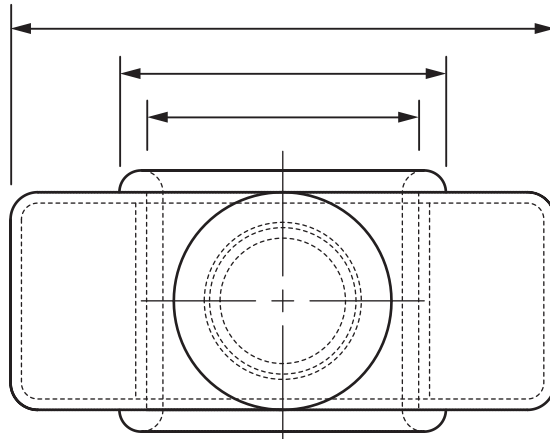

PLAN

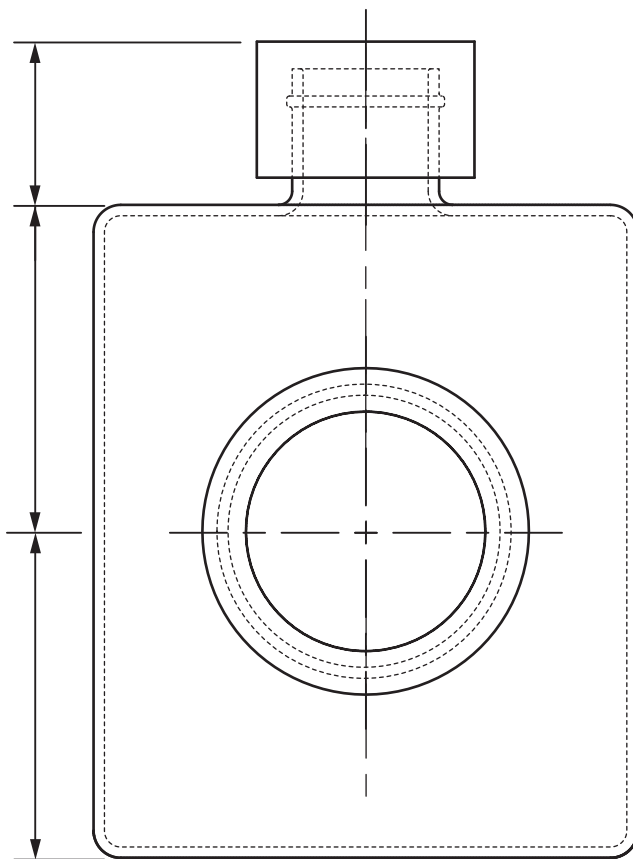

ELEVATION

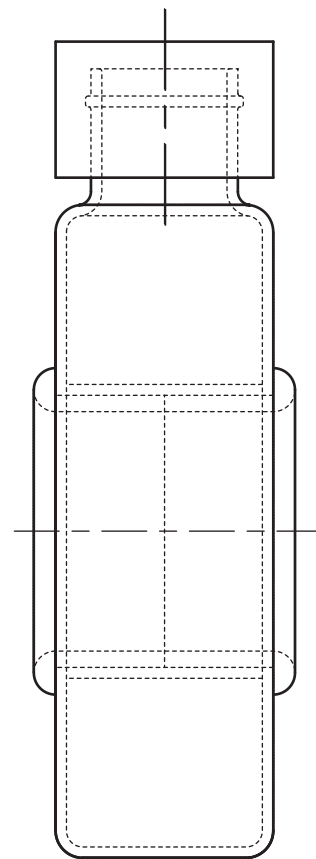

END ELEVATION

Not to scale

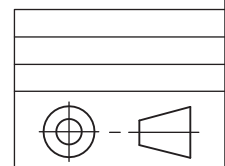

[BLANK PAGE]

DO NOT WRITE ON THIS PAGE