

FOR OFFICIAL USE



National  
Qualifications  
2019

Mark

**X835/75/01**

**Graphic Communication**

TUESDAY, 21 MAY

1:00 PM – 3:00 PM



\* X 8 3 5 7 5 0 1 \*

Fill in these boxes and read what is printed below.

Full name of centre

Town

Forename(s)

Surname

Number of seat

Date of birth

Day

Month

Year

Scottish candidate number

**Total marks — 80**

Attempt ALL questions.

All dimensions are in mm.

All technical sketches and drawings use third angle projection.

You may use rulers, compasses or trammels for measuring.

In all questions you may use sketches and annotations to support your answer if you wish.

Write your answers clearly in the spaces provided in this booklet. Additional space for answers is provided at the end of this booklet. If you use this space you must clearly identify the question number you are attempting.

Use **blue** or **black** ink.

Before leaving the examination room you must give this booklet to the Invigilator; if you do not, you may lose all the marks for this paper.



\* X 8 3 5 7 5 0 1 0 1 \*

Total marks — 80  
Attempt ALL questions

MARKS DO NOT WRITE IN THIS MARGIN

1. A range of marker pen packaging is shown below.

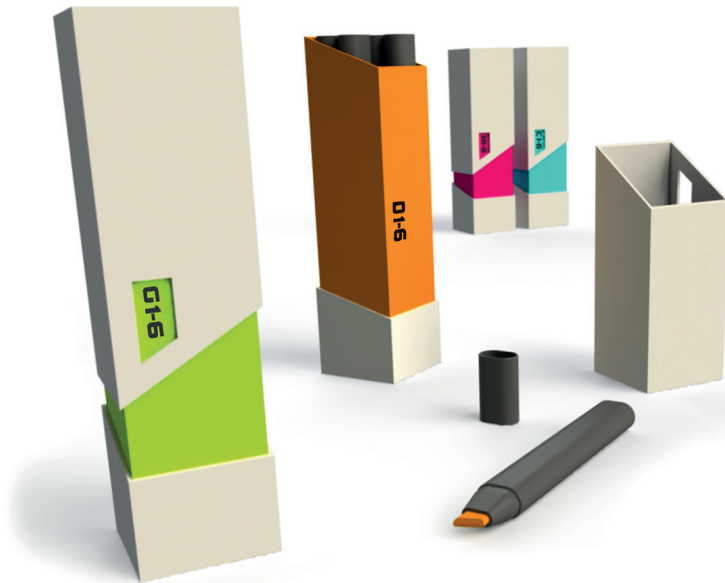

Rendered 3D CAD Illustration

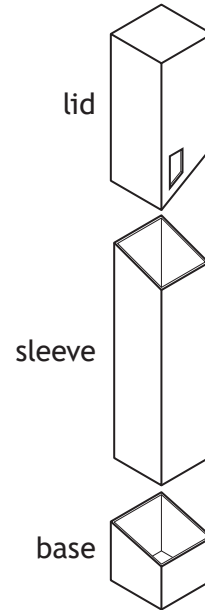

Exploded Pictorial View

(a) Identify the correct group of 3<sup>rd</sup> angle orthographic views for **the lid** by ticking (✓) a box below. Ignore wall thickness.

1

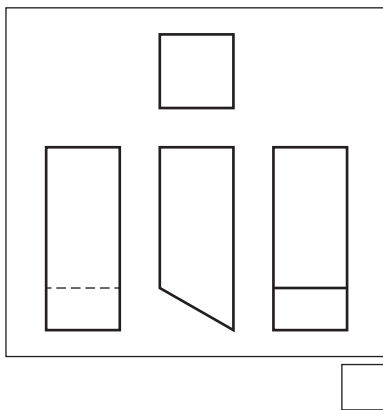

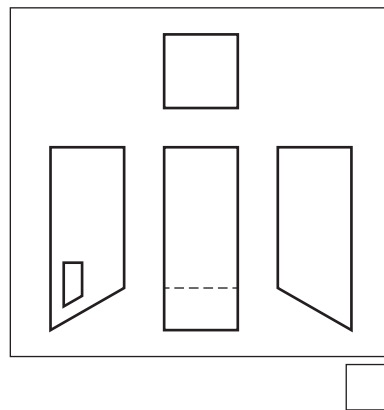

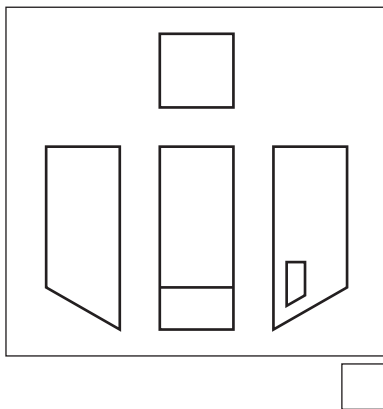

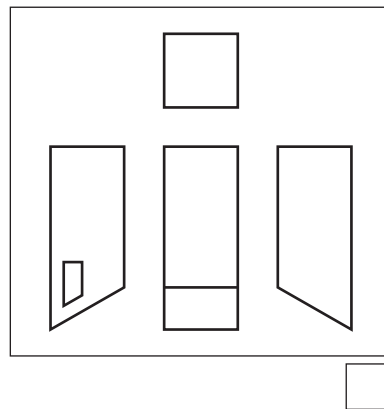

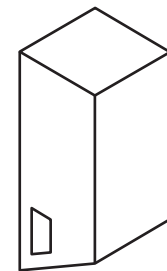

Pictorial View

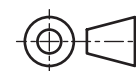

1. (continued)

MARKS

DO NOT WRITE IN THIS MARGIN

(b) Identify the correct group of 3<sup>rd</sup> angle orthographic views for the base by ticking (✓) a box below. Ignore wall thickness.

1

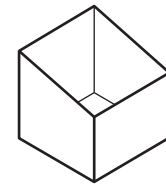
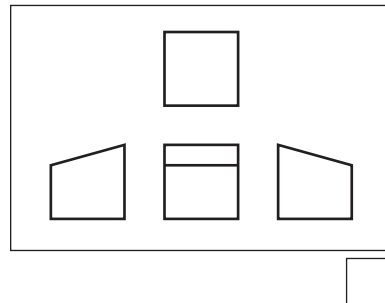
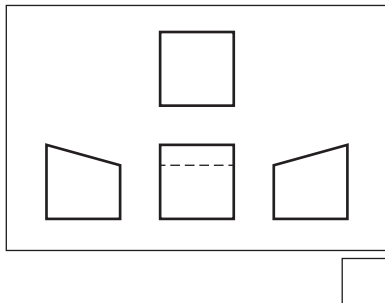

Pictorial View

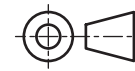
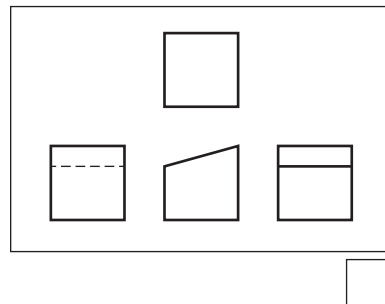
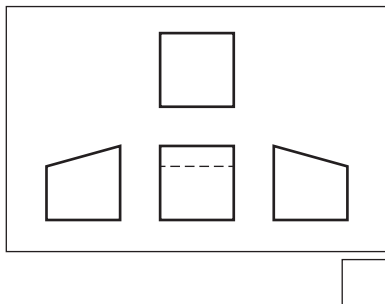

To complete the 2D CAD drawings required for manufacture, the CAD technician has been asked to produce the surface developments for the lid and base.

(c) Identify the correct surface development of the lid by ticking (✓) a box below.

1

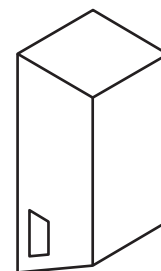
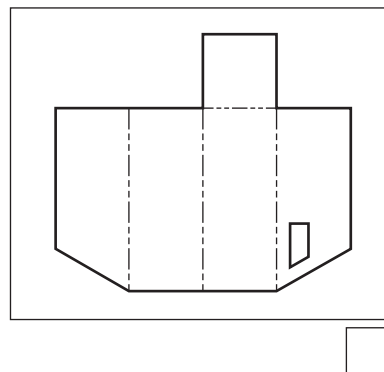
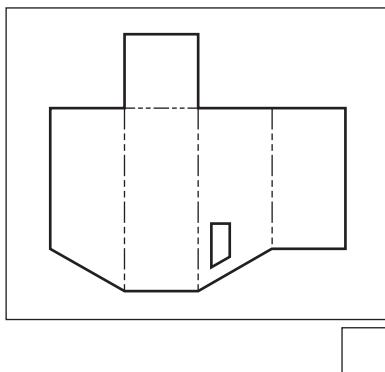

Pictorial View

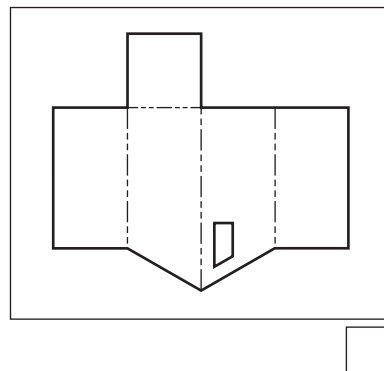
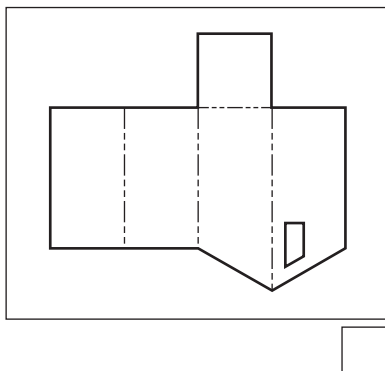

1. (continued)

MARKS

DO NOT WRITE IN THIS MARGIN

(d) Identify the correct surface development of **the base** by ticking (✓) a box below.

1

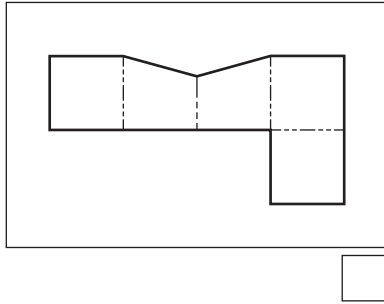

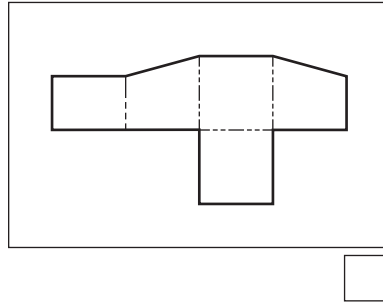

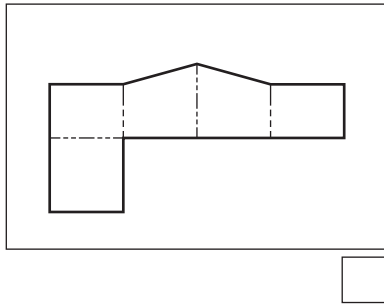

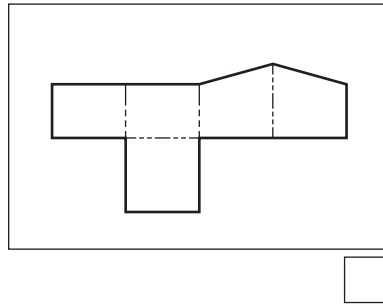

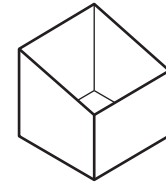

Pictorial View

Orthographic views of the assembled packaging are shown below.

(e) Identify the **two** pictorial assembly drawings that match the arrangement shown in the orthographic assembly by ticking (✓) a box below.

2

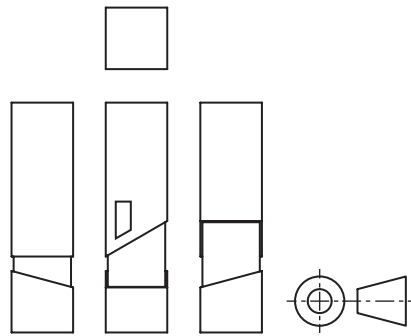

Orthographic Assembly Drawings

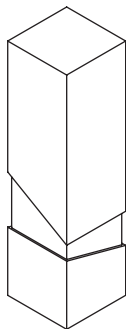

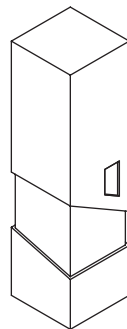

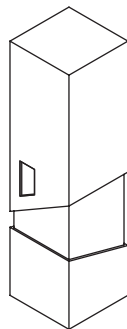

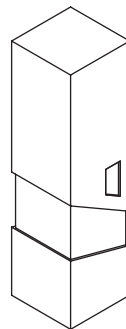

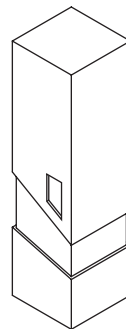

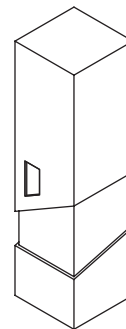



\* X 8 3 5 7 5 0 1 0 4 \*

[Turn over for next question

DO NOT WRITE ON THIS PAGE



\* X 8 3 5 7 5 0 1 0 5 \*

2. A graphic designer created a layout containing various infographics, shown below.

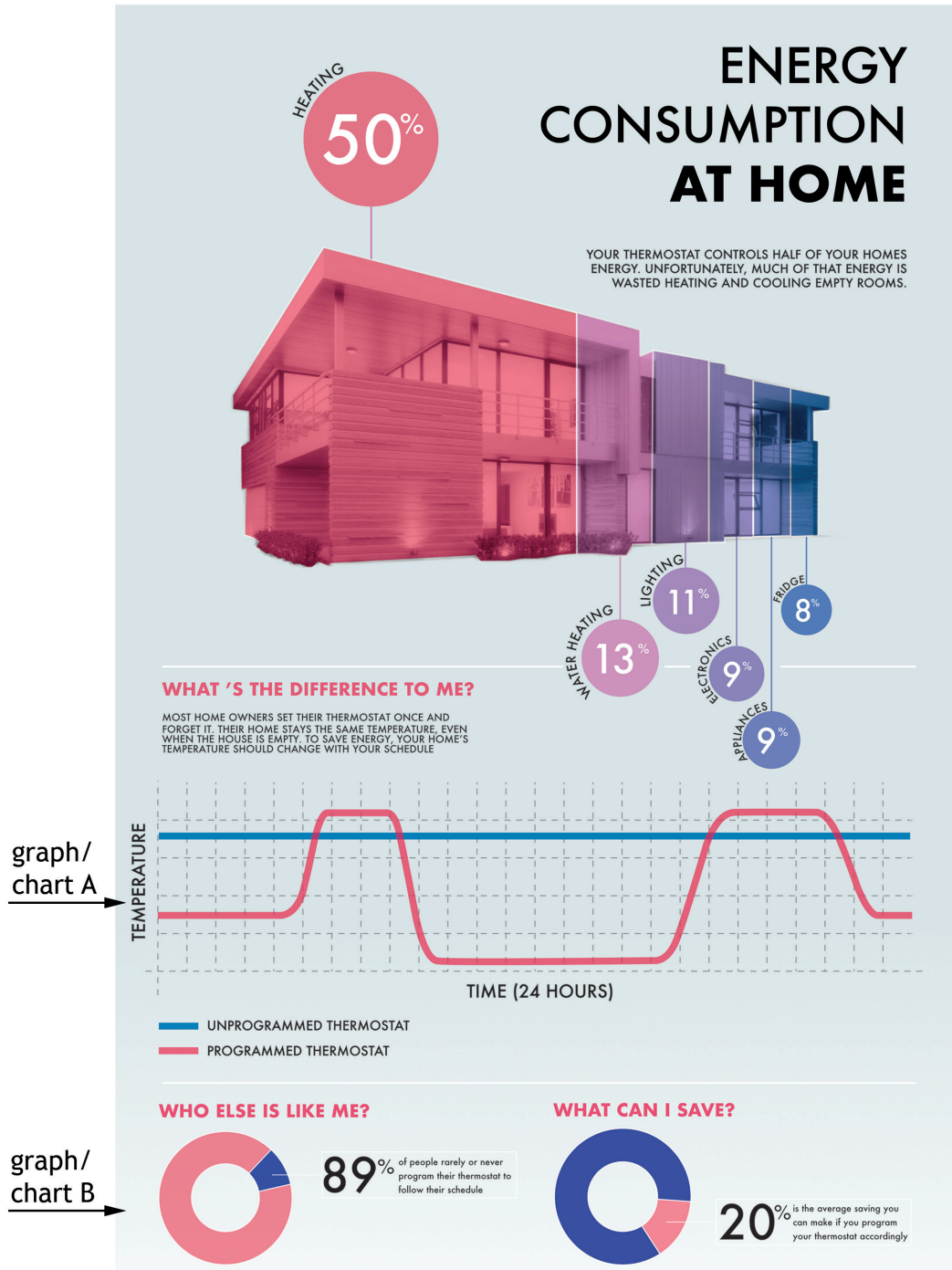

\* X 8 3 5 7 5 0 1 0 6 \*

2. (continued)

MARKS

DO NOT  
WRITE IN  
THIS  
MARGIN

(a) State the types of graph/chart shown at

(i) graph/chart A \_\_\_\_\_ 1

(ii) graph/chart B \_\_\_\_\_ 1

(b) Explain, giving reasons for your answer, why **graph/chart A** is appropriate for communicating this type of information. 2

---

---

---

---

(c) The graphic designer created a graph based on a photograph of a house to show the proportions of energy consumption in a home.

Describe **two ways** the designer has used proportion to convey the different percentages of consumption. 2

---

---

---

---

The graphic designer used DTP software to edit the image of the house by removing the background.

(d) (i) State the name of the DTP tool used to remove the background from an image. 1

---

(ii) Explain the advantages of removing the background from the image of the house. 1

---

---

[Turn over



\* X 8 3 5 7 5 0 1 0 7 \*

2. (continued)

MARKS  
DO NOT  
WRITE IN  
THIS  
MARGIN

Details from the layout are shown below.

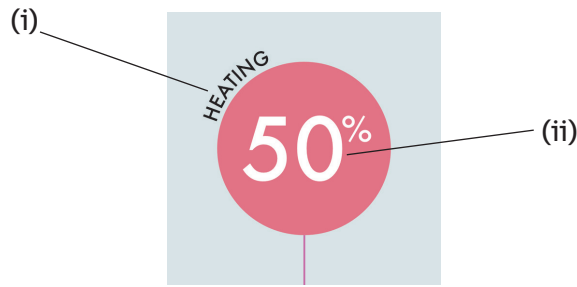

(e) State the name of the DTP technique shown on the layout at

(i) \_\_\_\_\_ 1

(ii) \_\_\_\_\_ 1

(f) Explain two ways the graphic designer can reduce the impact on the environment when printing the layout. 2

\_\_\_\_\_  
\_\_\_\_\_  
\_\_\_\_\_



3. An online portfolio site where designers can upload their CV and examples of design work is shown below.

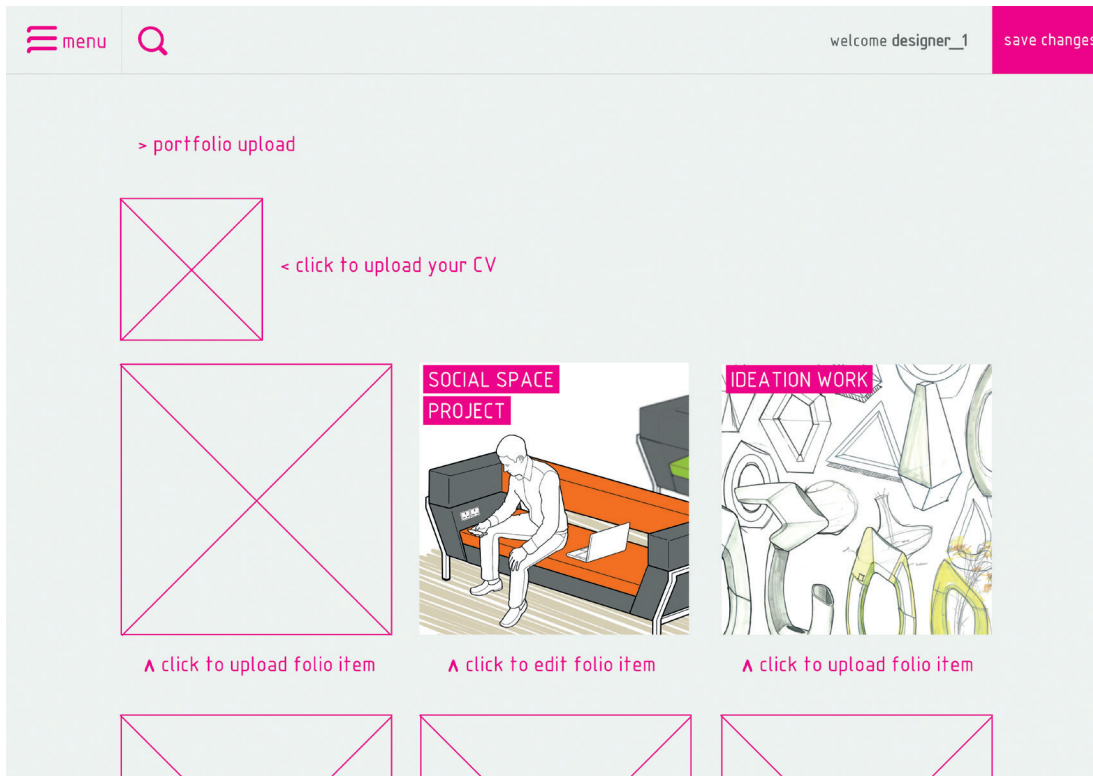

In order for a designer to build their portfolio online, they need to create digital copies of their manual work.

(a) State two **input devices** that could be used by designers to create digital files of their manual work. 2

---



---

(b) Explain **three** advantages to the designer of having their portfolio published online rather than being printed. 3

You **should not** refer to environmental advantages in you answer.

---



---



---



---



### 3. (continued)

DO NOT  
WRITE IN  
THIS  
MARGIN

A draft of a CV created using DTP software is shown below.



# MARA TAYLOR

PRODUCT DESIGNER

## PROFILE

Lorem ipsum dolor sit amet, consectetur adipiscing elit, sed diam nonummy nibh euismod tincidunt ut laoreet dolore magna Lorem ipsum dolor sit amet, consectetur adipiscing elit, sed diam nonummy nibh euismod tincidunt ut laoreet dolore magna aliquam erat volutpat. Ut wisi enim ad minim veniam, quis nostrud exerci tation ullamcorper suscipit lobortis nisl ut aliquip ex ea commodo consequat. Duis autem vel Lorem ipsum dolor sit amet, consectetur adipiscing elit, sed diam nonummy nibh euismod tincidunt ut laoreet

## SKILLS

- 3D MODELLING
- SKETCHING
- PROTOTYPING
- USER RESEARCH
- TEAM WORKING
- PRESENTING

## CONTACT

- ADDRESS LINE
- ADDRESS LINE
- WEBSITE
- TEL: NO

## EXPERIENCE

### USER CENTRED

Lorem ipsum dolor sit amet, consectetur adipiscing elit, sed diam nonummy nibh euismod tincidunt ut laoreet dolore magna Lorem ipsum dolor sit amet, consectetur adipiscing elit, sed diam nonummy nibh euismod tincidunt ut laoreet dolore magna aliquam erat volutpat. Ut wisi enim ad minim veniam, quis nostrud exerci tation ullamcorper suscipit lobortis nisl ut aliquip ex ea commodo consequat. Duis autem vel

### ERGONOMICS

Lorem ipsum dolor sit amet, consectetur adipiscing elit, sed diam nonummy nibh euismod tincidunt ut laoreet dolore magna Lorem ipsum dolor sit amet, consectetur adipiscing elit, sed diam nonummy nibh euismod tincidunt ut laoreet dolore magna aliquam erat volutpat. Ut wisi enim ad minim veniam, quis

### RESEARCH

Lorem ipsum dolor sit amet, consectetur adipiscing elit, sed diam nonummy nibh euismod tincidunt ut laoreet dolore magna Lorem ipsum dolor sit amet, consectetur adipiscing elit, sed diam nonummy nibh euismod tincidunt ut laoreet dolore magna aliquam erat volutpat. Ut wisi enim ad minim veniam, quis nostrud exerci tation ullamcorper suscipit lobortis nisl

### WEB DESIGN

Lorem ipsum dolor sit amet, consectetur adipiscing elit, sed diam nonummy nibh euismod tincidunt ut laoreet dolore magna Lorem ipsum dolor sit amet, consectetur adipiscing elit, sed diam nonummy nibh euismod tincidunt ut laoreet dolore magna aliquam

## EDUCATION

### PRODUCT DESIGN MSC

Lorem ipsum dolor sit amet, consectetur adipiscing elit, sed diam nonummy nibh euismod tincidunt ut laoreet dolore magna Lorem ipsum dolor sit amet, consectetur adipiscing elit, sed diam nonummy nibh euismod tincidunt ut laoreet dolore magna aliquam erat volutpat. Ut wisi enim ad minim veniam, quis

### PRODUCT DESIGN BSC(HONS)

Lorem ipsum dolor sit amet, consectetur adipiscing elit, sed diam nonummy nibh euismod tincidunt ut laoreet dolore magna Lorem ipsum dolor sit amet, consectetur adipiscing elit, sed diam nonummy nibh euismod tincidunt ut laoreet dolore magna aliquam erat volutpat. Ut wisi enim ad minim veniam, quis nostrud exerci tation ullamcorper suscipit lobortis nisl

## INTERESTS

- TRAVELLING
- MUSIC
- GOLF
- CYCLING



\* X 8 3 5 7 5 0 1 1 0 \*

3. (continued)

MARKS

DO NOT  
WRITE IN  
THIS  
MARGIN

(c) Explain **two** advantages to the designer of using DTP software to produce the CV.

2

---

---

---

---

(d) Describe **two** ways the designer has used each of the following design elements and principles in the CV.

(i) Alignment

2

---

---

(ii) Unity

2

---

---

(iii) Line

2

---

---

The designer used graphic icons to represent some information on the CV, as shown below.

INTERESTS



TRAVELLING

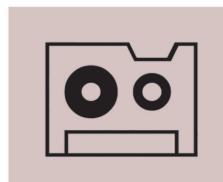

MUSIC



GOLF



CYCLING

(e) Explain why the designer used graphic icons.

1

---

---



\* X 8 3 5 7 5 0 1 1 1 \*

4. A 3D CAD illustration of a self-assembly children's toy is shown below.

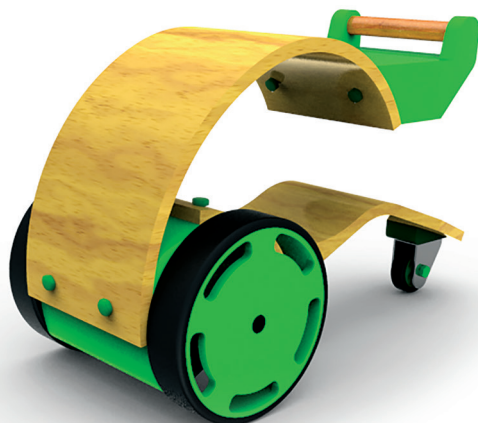

- (a) Explain **two** reasons why this type of graphic would be useful in the **promotion** of the toy.

2

---

---

---



\* X 8 3 5 7 5 0 1 1 2 \*

4. (continued)

DO NOT  
WRITE IN  
THIS  
MARGIN

The toy is made up of a number of parts. Two samples of assembly instructions are shown below: an exploded isometric drawing and a 3D CAD illustration.

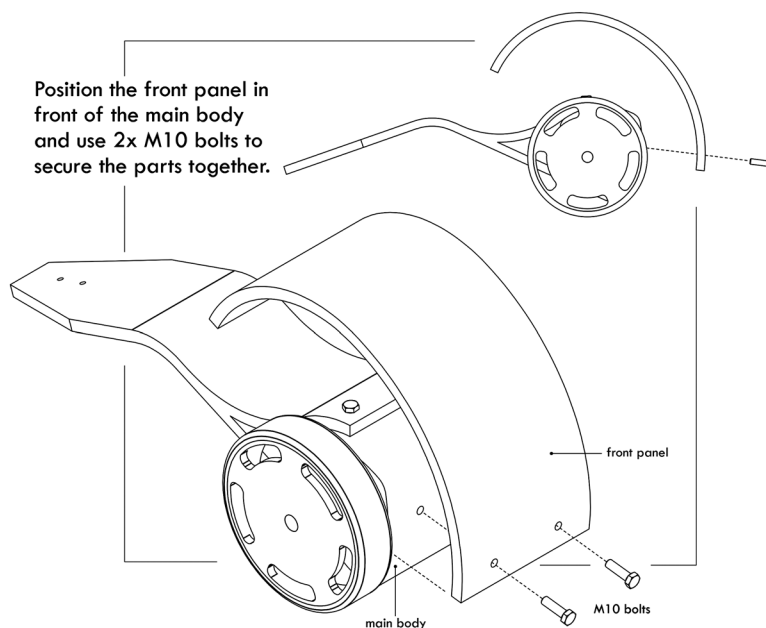

Exploded Isometric Drawing

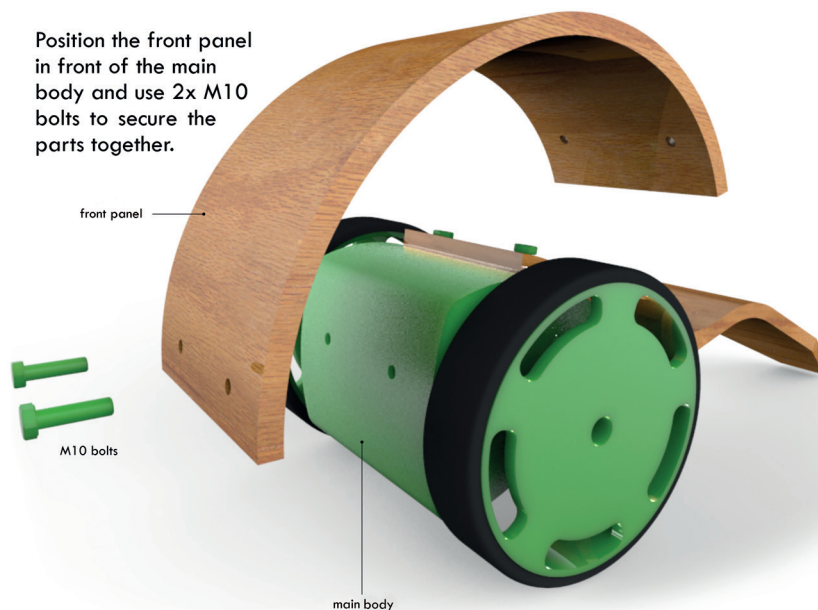

Rendered Illustration

[Turn over



\* X 8 3 5 7 5 0 1 1 3 \*

4. (continued)

MARKS

DO NOT  
WRITE IN  
THIS  
MARGIN

The designers need to decide on either exploded isometric drawings or rendered illustrations to be used in the assembly instructions.

(b) Explain **one** advantage and **one** disadvantage of each graphic.

Ensure you do not use the same answer more than once.

4

**Exploded isometric**

Advantage

---

---

Disadvantage

---

---

**3D CAD illustration**

Advantage

---

---

Disadvantage

---

---



\* X 8 3 5 7 5 0 1 1 4 \*

4. (continued)

MARKS  
DO NOT WRITE IN THIS MARGIN

An orthographic drawing of the children's toy is shown below. The orthographic drawing contains errors that do not conform to British Standards.

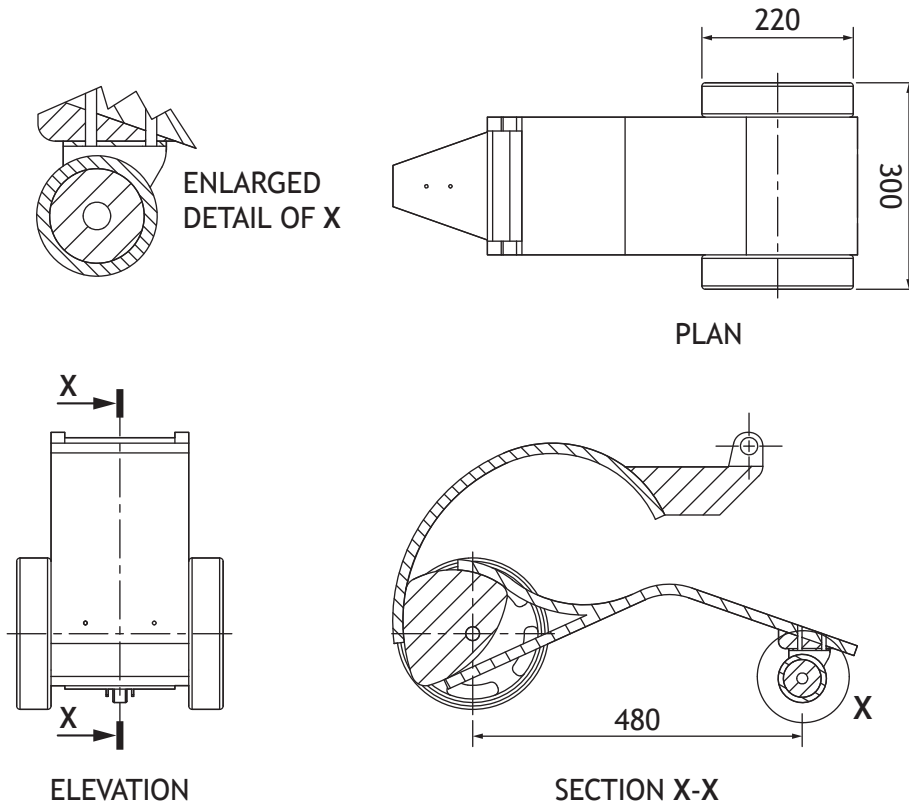

(c) State six errors shown in the orthographic drawing.

6

---



---



---



---



---



---

[Turn over



4. (continued)

MARKS

DO NOT  
WRITE IN  
THIS  
MARGIN

A title block is to be added to the final orthographic drawing. The title block will include the symbol shown below.

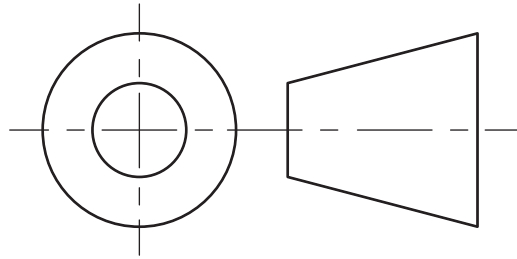

(d) (i) Describe the purpose of this symbol.

1

---

---

(ii) State **three** other pieces of information that should be included in a title block.

3

---

---

---



\* X 8 3 5 7 5 0 1 1 6 \*

[Turn over for next question

DO NOT WRITE ON THIS PAGE



\* X 8 3 5 7 5 0 1 1 7 \*

5. A new line of nail varnishes has been produced by a cosmetics manufacturer. The bottles are stackable for ease of storage and display. 3D CAD illustrations are shown below.

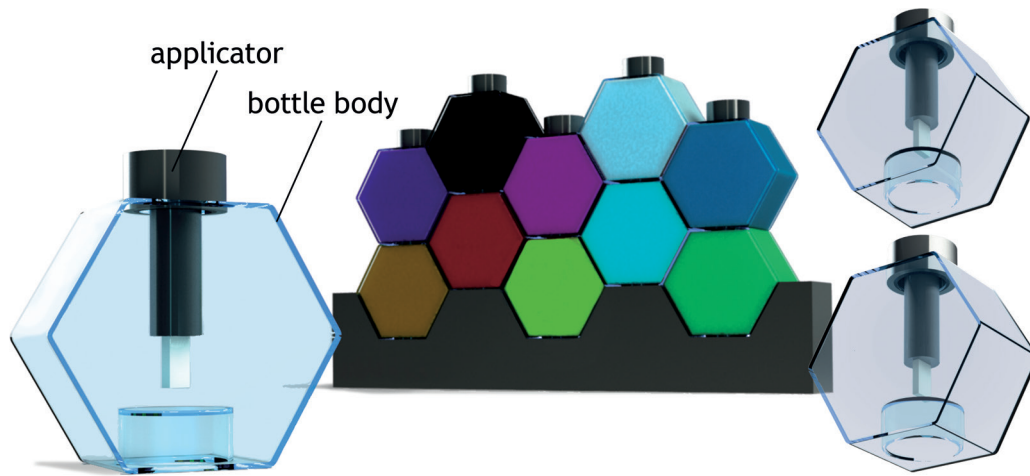

Orthographic drawings and a pictorial view of the bottle body are shown below.

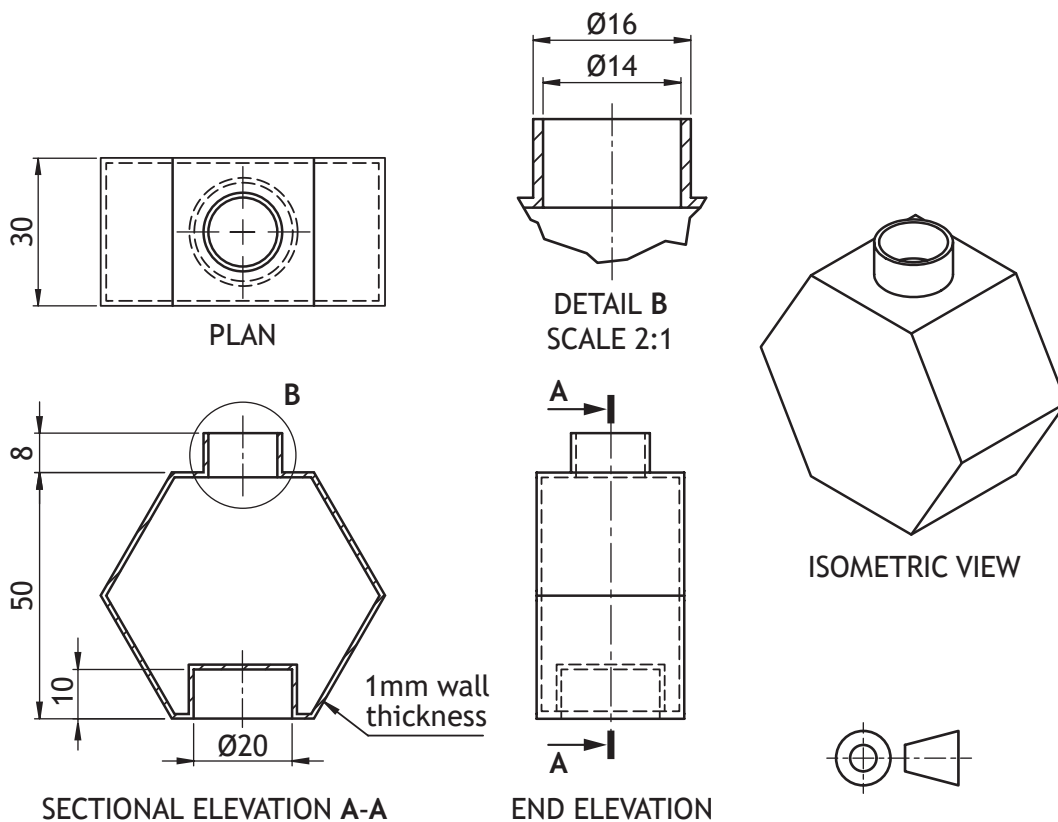

5. (continued)

MARKS

DO NOT  
WRITE IN  
THIS  
MARGIN

- (a) Describe, using the correct dimensions and 3D CAD modelling terms, how you would use 3D CAD software to model the bottle body. You may use sketches to support your answer.

6

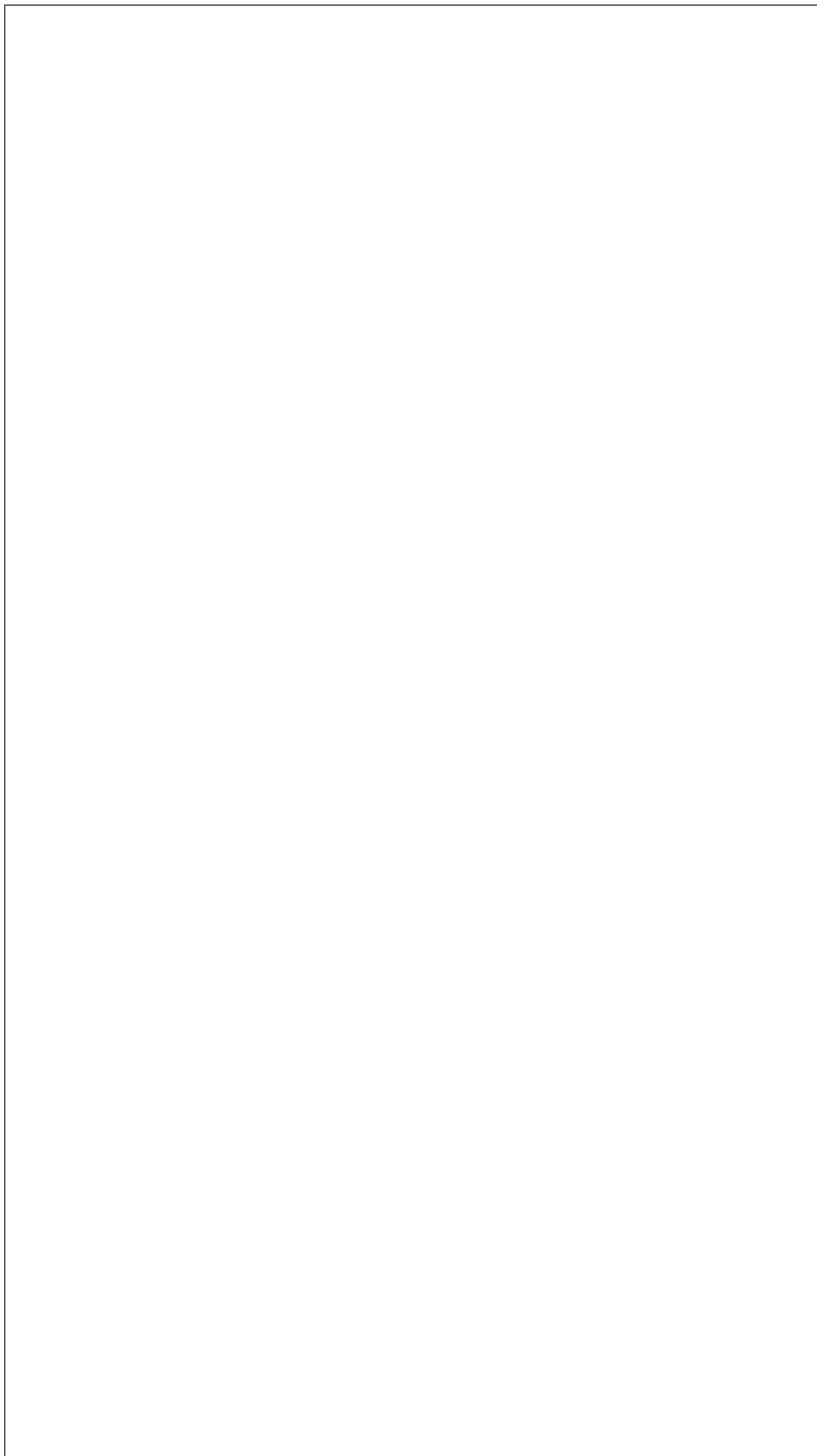

\* X 8 3 5 7 5 0 1 1 9 \*

5. (continued)

Orthographic drawings and a pictorial view of the applicator are shown below.

DO NOT  
WRITE IN  
THIS  
MARGIN

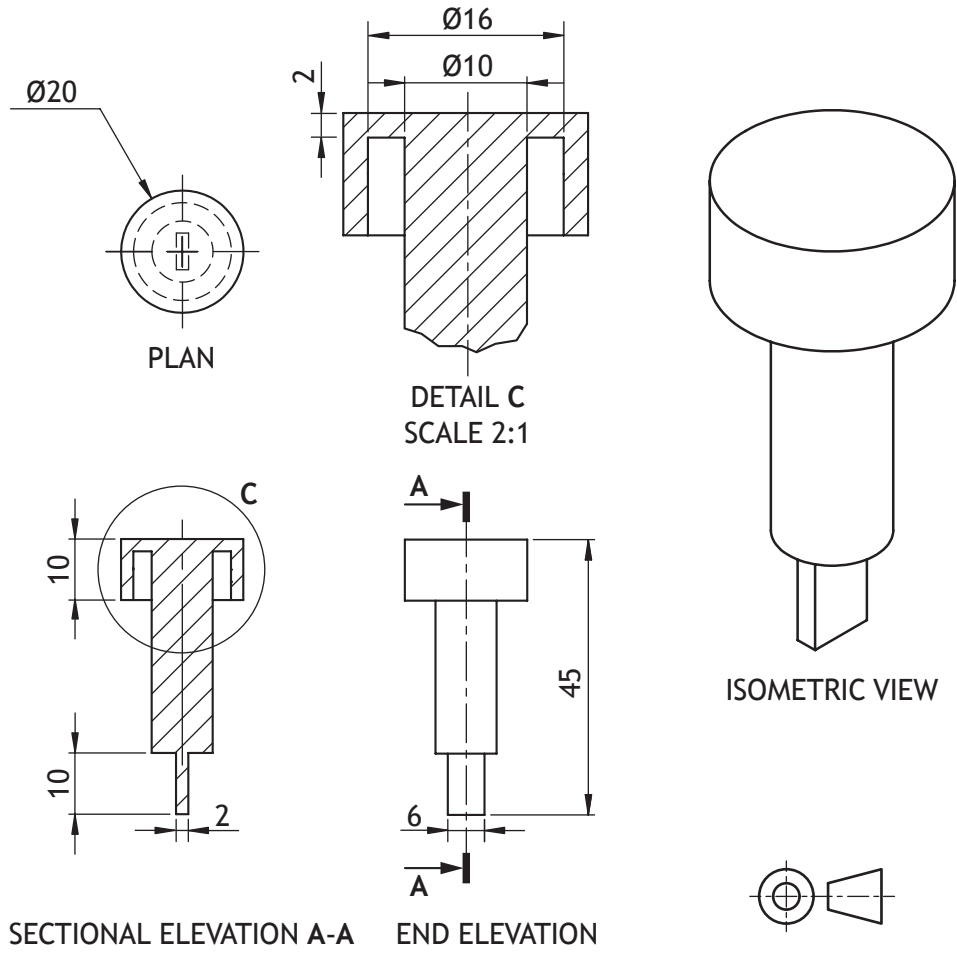

5. (continued)

MARKS  
DO NOT  
WRITE IN  
THIS  
MARGIN

- (b) Describe, using the correct dimensions and 3D CAD modelling terms, how you would use 3D CAD software to model the applicator. You may use sketches to support your answer.

4

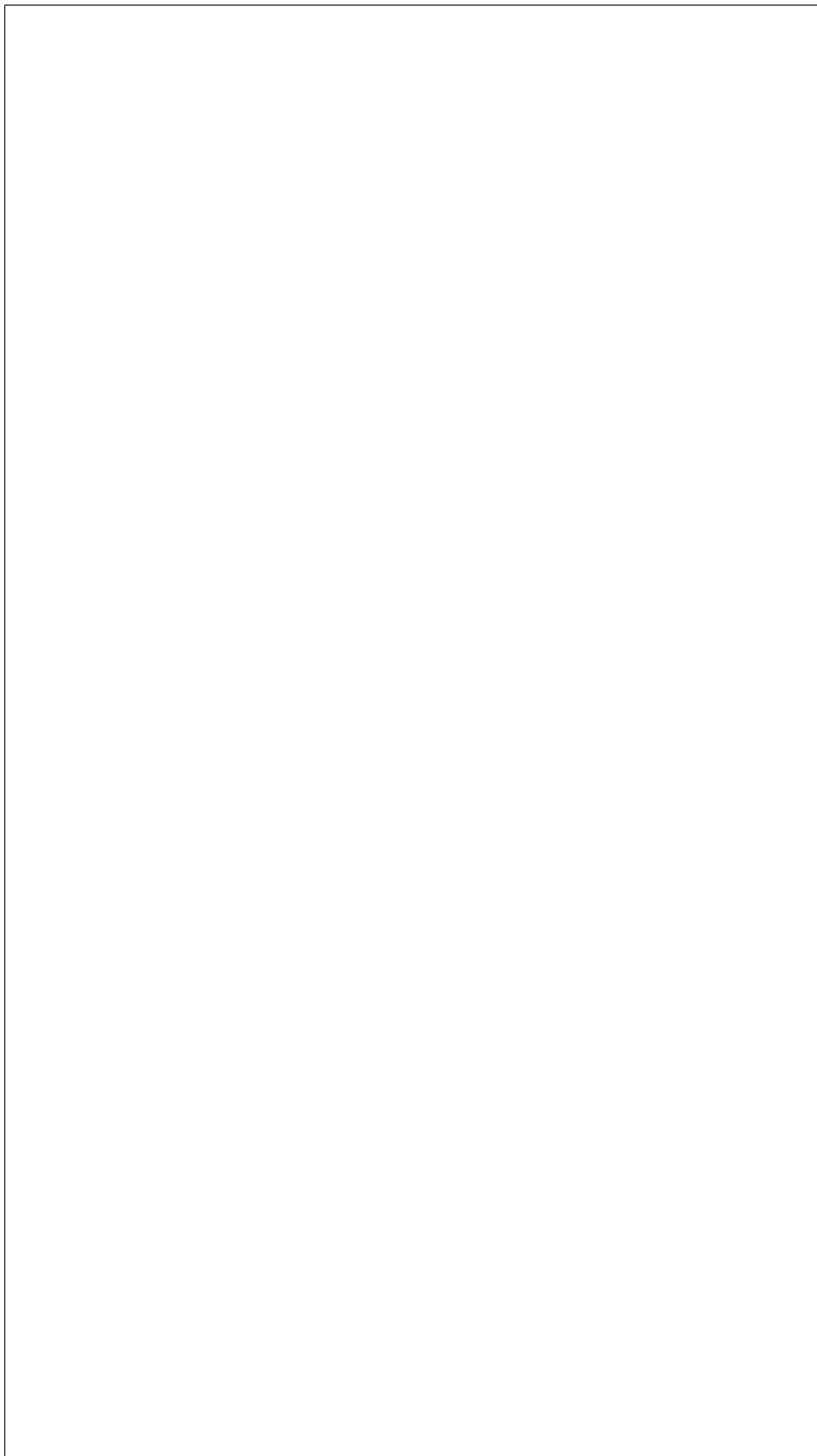



(c) The nail varnish is available in a wide range of colours, tints and shades. Complete the table below by adding the missing information.

6

Colour	Primary or secondary	Advancing or receding	Mood
red	primary		dangerous
green	secondary	receding	
blue		receding	formal
orange	secondary		appetising
yellow		advancing	

(d) Explain the difference between a tint and a shade.

1

---



---



---

(e) Explain how tertiary colours are created.

1

---



---



---



5. (continued)

Illustrated views of two bottles are shown below. There are three stages in the assembly.

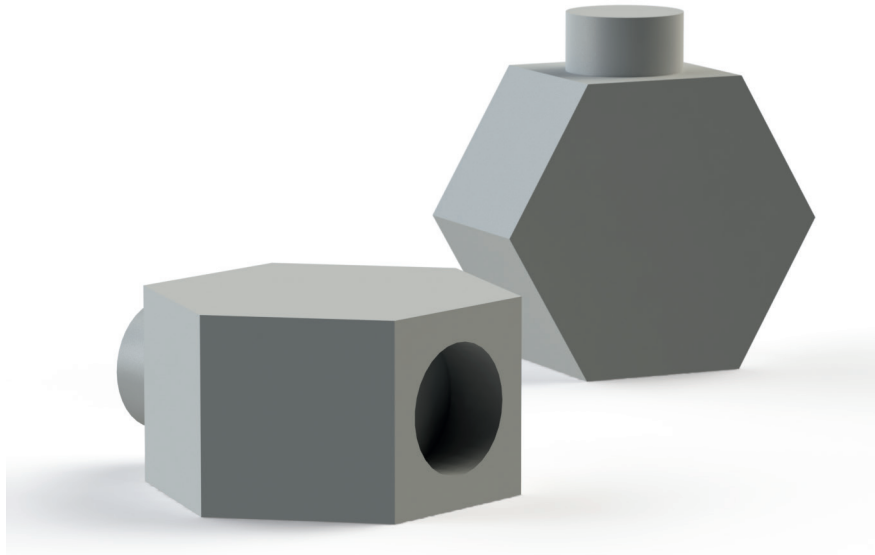

(f) State, using 3D CAD terms, how you would assemble and constrain the components shown above.

Corresponding surfaces and/or edges have been indicated for you.

3

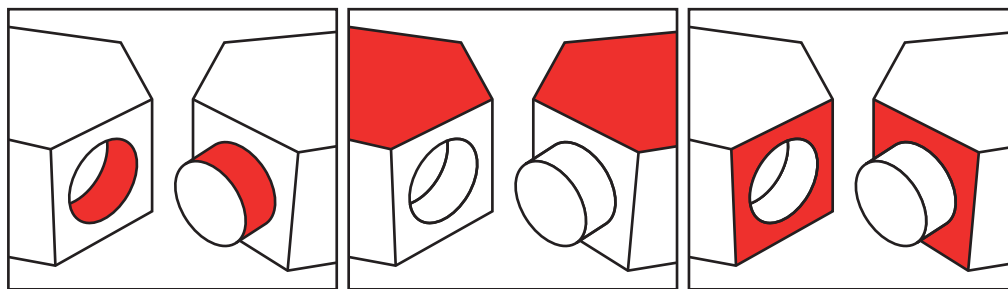

(i) Constraint used

(ii) Constraint used

(iii) Constraint used

\_\_\_\_\_

\_\_\_\_\_

\_\_\_\_\_

[Turn over



6. An outdoor play system has been produced. Various arrangements can be made using four tunnel sections. Each section is colour coded on the inside. A 3D CAD illustration and pictorial line drawings are shown below.

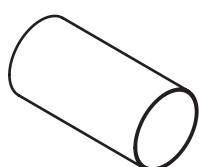
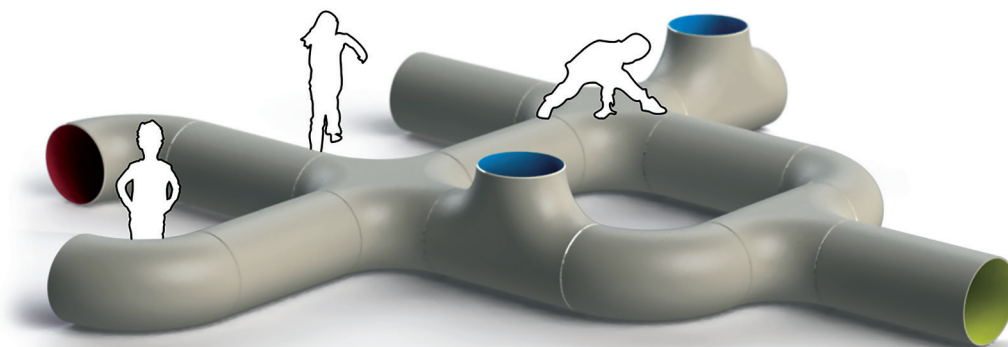

Section 1

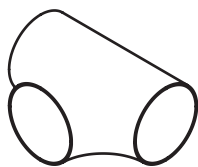

Section 2

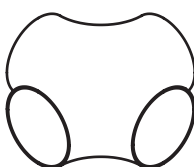

Section 3



Section 4

Pictorial Line Drawings

- (a) An incomplete parts list for the 3D illustration is shown below.

Complete the table below by adding the missing information. Use the arrangement shown in the rendered 3D CAD illustration above.

6

	Quantity	Colour
Section 1	6	
Section 2		
Section 3		magenta
Section 4		



\* X 8 3 5 7 5 0 1 2 4 \*

6. (continued)

MARKS

DO NOT  
WRITE IN  
THIS  
MARGIN

- (b) Orthographic drawings and a pictorial view of one of the tunnel sections is shown below.

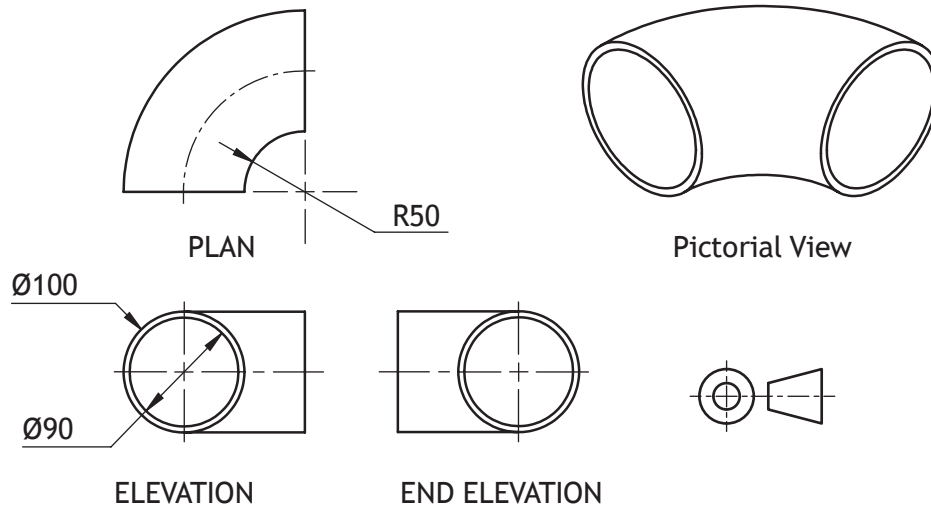

Describe, using the correct dimensions and 3D CAD modelling terms, how you would use 3D CAD software to model section 4. You may use sketches to support your answer.

3



\* X 8 3 5 7 5 0 1 2 5 \*

6. (continued)

MARKS  
DO NOT  
WRITE IN  
THIS  
MARGIN

An orthographic assembled plan of one arrangement is shown below.

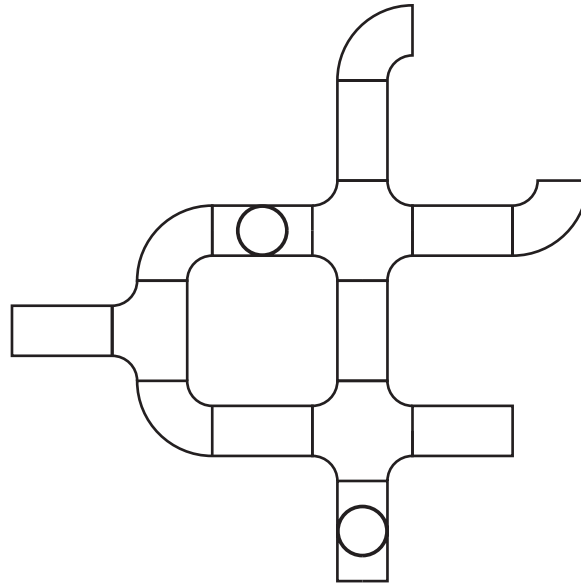

(c) Identify the **two** correct pictorial assembly drawings that match the orthographic plan shown above by ticking (✓) a box below.

2

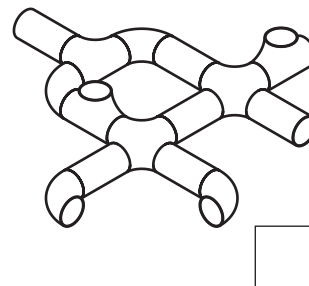
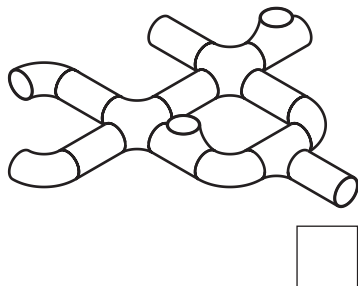
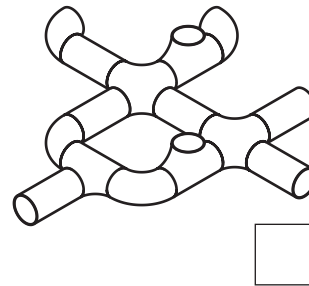
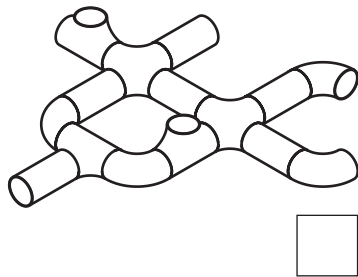
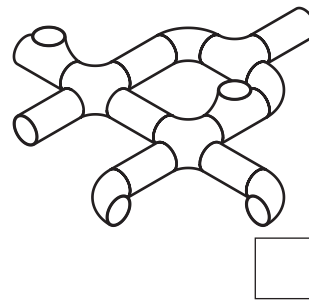
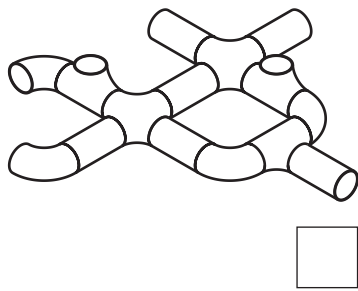

[END OF QUESTION PAPER]



MARKS

DO NOT  
WRITE IN  
THIS  
MARGIN

ADDITIONAL SPACE FOR ANSWERS



\* X 8 3 5 7 5 0 1 2 7 \*

MARKS

DO NOT  
WRITE IN  
THIS  
MARGIN

ADDITIONAL SPACE FOR ANSWERS

*Acknowledgement of copyright*

Question 3 (c) Roman Samborskyi/shutterstock.com



\* X 8 3 5 7 5 0 1 2 8 \*