



National 5
Coursework
Assessment Task



National 5 Graphic Communication Assignment Assessment task

Valid for session 2024-25 only.

This assessment is given to centres in strictest confidence. You must keep it in a secure place until it is used.

This edition: January 2025 (version 1.2)

© Scottish Qualifications Authority 2024

Contents

Introduction	1
Instructions for teachers and lecturers	2
Instructions for candidates	5

Introduction

This document contains instructions for teachers and lecturers and instructions for candidates for the National 5 Graphic Communication assignment.

This assignment has 40 marks out of a total of 120 marks available for the course assessment.

This is one of two course assessment components. The other component is a question paper.

Instructions for teachers and lecturers

You must conduct the assignment under a high degree of supervision and control. This means:

- ◆ candidates must be within your direct sight
- ◆ candidates must not interact with each other
- ◆ candidates must not have access to email, the internet and mobile phones
- ◆ candidates must complete their work independently – no group work is permitted
- ◆ classroom display materials that might provide assistance must be removed or covered
- ◆ with no interruption for learning and teaching
- ◆ in a classroom environment

Time

Candidates have 8 hours to complete the assignment, starting at an appropriate point in the course after all content has been delivered. Once candidates begin, they must continue in each subsequent class period until the permitted time allocation has been used up.

You have a responsibility to manage candidates' work, distributing it at the beginning and collecting it at the end of each session, and storing it securely in-between. This activity does not count towards the total time permitted for candidates to complete the assignment.

Resources

This is a closed-book assessment. Candidates must not have access to learning and teaching materials, the internet, notes, exemplar materials, resources on classroom walls or anything similar.

There may be instances where restriction of internet and/or network use is prohibited (for example, if you have a local authority-managed network with specific limitations or CAD software that is web-based). However, it remains your professional responsibility to make every effort to meet the assessment conditions.

Each assessment task includes instructions and details of any equipment or materials required. Candidates can also use normal classroom equipment, software and hardware (such as CAD and DTP software, and PCs to run the software) to complete the tasks.

Reasonable assistance

Candidates must progress through each stage of the assignment without your intervention or guidance, having acquired the skills earlier in the course.

Once candidates complete the assignment, you must not return it to them for further work. You must not provide feedback to candidates or offer an opinion on the perceived quality or completeness of the assignment response at any stage.

You can provide reasonable assistance to support candidates with the following aspects of their assignment:

- ◆ printing, collating, stapling and labelling their evidence to ensure it is in the format specified by SQA
- ◆ ensuring candidates have all the materials and equipment required to complete the assignment
- ◆ understanding the information outlined in these instructions

Evidence

All candidate evidence (whether created manually or electronically) must be submitted to SQA in paper-based format.

Each task details what evidence is required and how many pages are expected. This is a guide to ensure that candidates do not produce too much work or spend too long on a single task. Single-sided A3 pages are preferred and are typically the most suitable for the tasks; however, it is acceptable to submit A4 pages if an A3 printer is not available.

Each piece of work must be labelled with the task number, for example, task 1a, and the back of each page must be clearly labelled with candidate details.

Alteration or adaptation

You must not alter, adapt or modify the assignment in any way. This includes moving the content of the assignment into a different format or workbook. All candidates must undertake the assignment exactly as it is provided.

Volume

Candidates should present their work on a maximum of eight single-sided A3 pages.

This figure is given to indicate the volume of evidence required; however, no penalty is applied where candidates exceed this. Full details of evidence requirements are contained within each assessment task.

Specific instructions for teachers and lecturers

You must follow these specific instructions. You must ensure that candidates are aware of the assessment conditions and know what they should do for each task.

Prior to candidates starting the assignment, you must download the following electronic files for their use. You must keep these files secure and candidates must not access them prior to assessment.

- ◆ data sheet 2a – graphic of logo
- ◆ data sheet 2b – images 1 to 7
- ◆ data sheet 2c – images 8 to 13

This assignment has three tasks, all of which are mandatory. Candidates must complete the tasks in order.

Each task has a notional time allocated to it. This is not mandatory and is an indication of how long candidates should spend on the task.

Task 1 – 15 marks: producing production drawings for a microphone
(suggested time 3 hours)

- ◆ Task 1: candidates must produce their production drawings electronically and generate them from a 3D CAD model.

Task 2 – 15 marks: producing promotional and preliminary graphics for a microphone
(suggested time 3 hours)

- ◆ Task 2a: candidates must complete this electronically.
- ◆ Task 2b: candidates can complete this manually or electronically.
- ◆ Task 2c: candidates must complete this electronically.
- ◆ Task 2c: candidates must identify where they have used three design elements and principles from the list in the task.
- ◆ Task 2c: candidates must identify where they have used **reverse text**.

Task 3 – 10 marks: producing preliminary graphics for a ring light
(suggested time 2 hours)

- ◆ Tasks 3a and 3b: candidates are expected to complete these manually. If they use an electronic method, it **must not** be 3D CAD software, as they will gain no marks.
- ◆ Tasks 3a and 3b: if candidates use electronic sketching software, they are only permitted to use a straight edge. They **must not** use any other tools.
- ◆ Tasks 3a and 3b: candidates **must not** use drawing boards and set squares.
- ◆ Tasks 3a and 3b: candidates will gain no marks if there is evidence they have used drawing instruments other than a straight edge.

Note: candidates must not trace drawings for any part of the assignment. They will gain no marks for traced drawings.

All electronically generated evidence must be printed and compiled for uplift by SQA.

Instructions for candidates

This assessment applies to the assignment for National 5 Graphic Communication.

This assignment has 40 marks out of a total of 120 marks available for the course assessment.

It assesses the following skills, knowledge and understanding:

- ◆ demonstrating graphic design skills and creativity
- ◆ using graphic communication technologies
- ◆ producing preliminary, production and promotional graphic items in response to a situation or problem
- ◆ using illustration techniques to create graphics with relevant visual impact
- ◆ producing 2D and 3D production drawings, applying appropriate standards, protocols and conventions (drawing includes manual or electronic production methodologies)
- ◆ reviewing and evaluating your progress, giving justification for your choice of graphic items and the graphic communication techniques employed

This is a closed-booked assessment. Your teacher or lecturer will let you know if there are any specific conditions for doing this assessment.

Read each task fully before starting.

Note: you must not trace drawings for any part of the assignment. You will gain no marks for traced drawings.

In this assessment, you have to:

- ◆ produce a range of graphics in response to a series of tasks, which will test aspects of the skills and knowledge listed above
- ◆ complete all of the tasks in the order presented

You have 8 hours to complete the assignment, excluding the time required to set up and clear away any equipment you need, and for any printing that is required.

You must not use any text, images, or other items from any other source unless you created them during this 8-hour assignment.

The assignment has three tasks, with marks allocated as follows:

Task 1 – 15 marks: producing production drawings for a microphone
(suggested time 3 hours)

Task 2 – 15 marks: producing promotional and preliminary graphics for a microphone
(suggested time 3 hours)

Task 3 – 10 marks: producing preliminary graphics for a ring light
(suggested time 2 hours)

Your teacher or lecturer will provide you with:

- ◆ tasks 1 to 3
- ◆ data sheets 1a to 1e, 2a to 2c and 3a to 3c
- ◆ electronic files for task 2

Assessment conditions

This is a closed-book assessment. You must undertake the assignment under a high degree of supervision and control. This means:

- ◆ you must be within direct sight of your teacher or lecturer
- ◆ you must not interact with other candidates
- ◆ you must not have access to email, the internet and mobile phones
- ◆ you must complete your work independently – no group work is permitted

You have 8 hours to complete the assignment. Once you begin, you must continue in each subsequent class period until the permitted time allocation has been used up.

Reasonable assistance

You must progress through each stage of the assignment without intervention or guidance from your teacher or lecturer.

Once you have completed the assignment, your teacher or lecturer cannot return it to you for further work. They will not give you feedback on your assignment response at any stage. They can give you reasonable assistance to support with the following aspects of your assignment:

- ◆ printing, collating, stapling and labelling your evidence to ensure it is in the format specified by SQA
- ◆ ensuring you have all the materials and equipment required to complete the assignment
- ◆ understanding the information in these instructions

Submitting your work

You must label each piece of evidence with the task number (for example task 1a), and the back of each page must be clearly labelled with your:

- ◆ name
- ◆ date of birth
- ◆ Scottish Candidate Number (SCN)
- ◆ centre name
- ◆ centre number

Task 1: microphone production drawings

PodSphere, an electronics company, is launching a range of podcasting accessories.

Using the information on data sheets 1a to 1e, model and assemble the microphone components using 3D CAD software.

From these models, produce production drawings that will allow the microphone to be manufactured.

- 1a Produce suitable component orthographic views of the four components of the microphone.

You must produce an elevation and a plan for the:

- ◆ rubber ring
- ◆ microphone top

You must produce an elevation, end elevation and a plan for the:

- ◆ microphone stand
- ◆ microphone body

You must:

- ◆ use third-angle projection
- ◆ **show all** hidden detail
- ◆ **show all** centre marks
- ◆ produce the elevation of each component in the same direction as the data sheets
- ◆ include enough dimensions to allow for manufacture
- ◆ include annotations
- ◆ produce the views to a suitable scale

(8 marks)

- 1b Produce an elevation, a plan and a sectional end elevation of the assembled microphone.

The sectional end elevation **must** cut through the vertical centre of the microphone and stand.

You must:

- ◆ use third-angle projection
- ◆ **not** show hidden detail
- ◆ **show all** centre marks
- ◆ produce the elevation in the same direction as data sheet 1a
- ◆ produce the views as line drawings
- ◆ produce the views at a scale of 1:2

(3 marks)

1c Produce an exploded isometric view of the microphone.

You must:

- ◆ not show hidden detail
- ◆ produce the view in the same direction as the exploded pictorial view on data sheet 1a
- ◆ produce the view as a line drawing
- ◆ **not** render the view

(2 marks)

1d Include correct British Standard conventions and line types on all of your drawings.

(2 marks)

Note: you must create the production drawings for task 1 electronically and print them out.

You should complete task 1 on a maximum of four single-sided A3-sized pages.

You should spend approximately 3 hours on task 1.

Your completed assignment (tasks 1 to 3) should be on no more than eight single-sided A3-sized pages.

Task 2: microphone promotional and preliminary graphics

PodSphere would like you to produce a CAD-rendered pictorial illustration of the microphone and a promotional graphic layout for a magazine advert.

Your teacher or lecturer will give you electronic files of the graphics from data sheets 2a to 2c.

In tasks 2b and 2c you must:

- ◆ use the logo on data sheet 2a — you can use the logo as it is, or you can edit the colour to suit your design
- ◆ use the company name on data sheet 2a
- ◆ use at least **one** of the images on data sheets 2b and 2c — you can use the images as they are, or you can edit them to suit your design
- ◆ **not** use any text or images from any other sources such as the internet — if you do this, you will gain 0 marks for task 2c

2a Produce a CAD-rendered pictorial illustration of the assembled microphone you modelled in task 1, complete with appropriate materials, highlights and shadows.

You must use the following materials when producing your CAD render:

- ◆ rubber ring: rubber
- ◆ microphone top: mesh pattern — edit the mesh pattern to a suitable scale (if a mesh pattern is not available use a similar woven or composite material edited to a suitable scale)
- ◆ microphone body: plastic — any colour except black
- ◆ microphone stand: metal

(2 marks)

2b Produce two preliminary layouts/thumbnails of the microphone magazine advert.

You can use a manual or electronic method to complete this task.

Your layouts/thumbnails must contain:

- ◆ the company logo
- ◆ the company name
- ◆ at least one of the images from data sheets 2b or 2c
- ◆ at least **one** piece of the extended text from data sheet 2a

You must annotate your layout, identifying where you have used the logo, the image(s) and the extended text.

(2 marks)

2c Produce a final version of a promotional graphic layout of the microphone magazine advert.

You may use the CAD-rendered pictorial illustration of the assembled microphone you produced in task 2a in your advert.

PodSphere has specified that the graphic layout **must**:

- ◆ have the dimensions and orientation from data sheet 2a
- ◆ have high-quality visual impact
- ◆ make effective use of the company logo and name from data sheet 2a
- ◆ make effective use of at least one piece of the extended text from data sheet 2a
- ◆ make effective use of at least one image from data sheets 2b or 2c
- ◆ use only the images supplied by the company (see data sheets 2b and 2c)

You **must** make effective use of at least three of the following design elements and principles in your graphic layout.

- ◆ alignment
- ◆ contrast
- ◆ depth
- ◆ dominance
- ◆ line
- ◆ unity
- ◆ use of colour (warm, cool, contrast, harmony, advancing, receding, mood)

You **must** also include effective use of **reverse text** in your graphic layout.

You **must** annotate your graphic layout:

- ◆ **Identify** where you have used **three** of the design elements and principles in your graphic layout. You do not need to describe the effect of the design elements and principles on your layout.
- ◆ **Identify** where you have used **reverse text** in your graphic layout.

(11 marks)

Note: you should complete task 2 on a maximum of two single-sided sheets of A3-sized pages.

You should spend approximately 3 hours on task 2.

Your completed assignment (tasks 1 to 3) should be no more than eight single-sided A3-sized pages.

Task 3: ring light

PodSphere is adding a ring light to its range of podcasting accessories.

Using the drawings from data sheets 3a to 3c, produce preliminary sketches for the ring light.

Task 3 assesses your sketching skills. **Do not** use a drawing board or a set square. If you measure, trace or use any drawing instruments other than a straight edge, you will gain 0 marks for this task. In task 3b, you **must not** trace drawings from the data sheets.

You should complete this task manually. If you use an electronic method, it must not be 3D CAD software. If you use electronic sketching software, you are only allowed to use a straight edge. No other tools are allowed.

3a Produce preliminary orthographic sketches of the ring light components:

- ◆ ring light – elevation, end elevation and plan
- ◆ rod – elevation and plan
- ◆ stand – elevation, end elevation and plan

You do not need to show any dimensions on your sketches.

You **must**:

- ◆ sketch the elevation of each ring light component in the direction shown on data sheets 3b to 3c
- ◆ use third-angle projection
- ◆ show all hidden detail

(6 marks)

3b Produce a rendered pictorial sketch of the assembled ring light, showing appropriate highlights, shadows and materials.

The components must be made from the following materials:

- ◆ ring light: plastic
- ◆ rod: plastic
- ◆ stand: metal

Do not show hidden detail.

Do not include the computer monitor as part of your sketch.

(4 marks)

Note: you should complete task 3 on a maximum of two single-sided sheets of A3-sized pages.

You should spend approximately 2 hours on task 3.

Your completed assignment (tasks 1 to 3) should be on no more than eight single-sided A3-sized pages.

Data sheet 1a

Pictorial views and exploded pictorial view

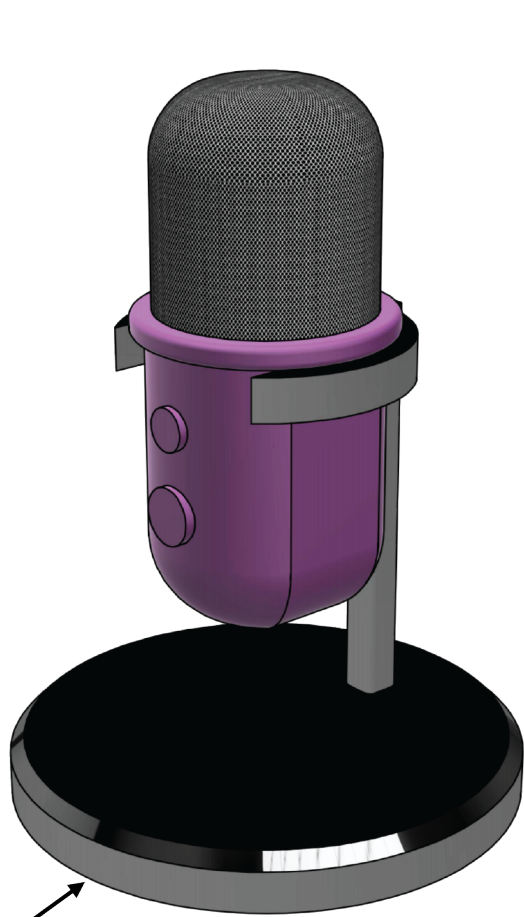

PICTORIAL VIEW

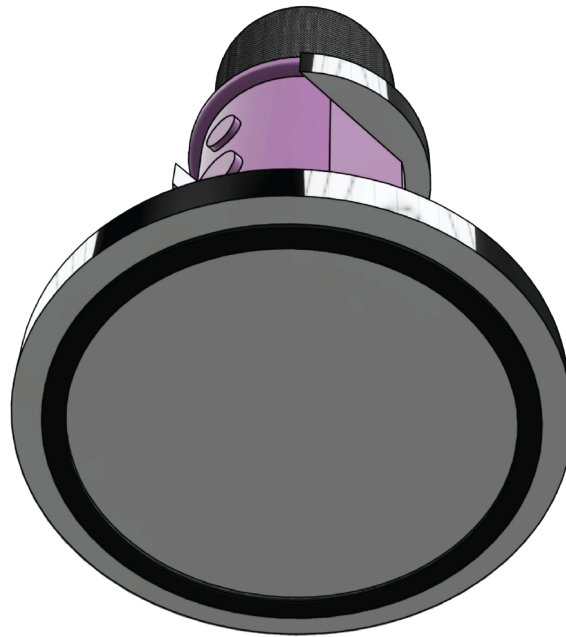

PICTORIAL VIEW SHOWING RUBBER RING IN PLACE

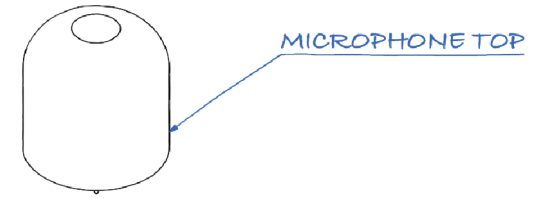

MICROPHONE TOP

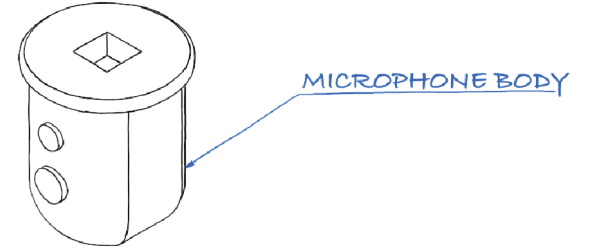

MICROPHONE BODY

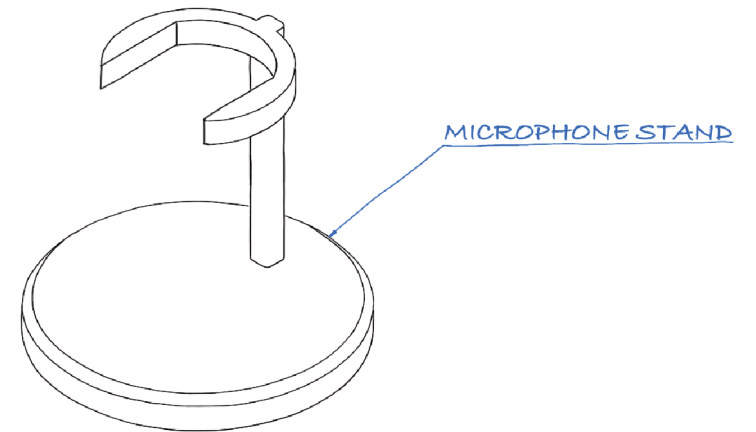

MICROPHONE STAND

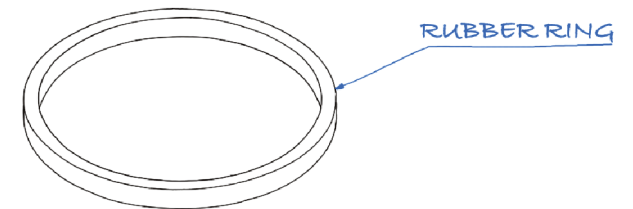

RUBBER RING

EXPLODED PICTORIAL VIEW

Elevation
Task 1b

Data sheet 1b

Rubber ring

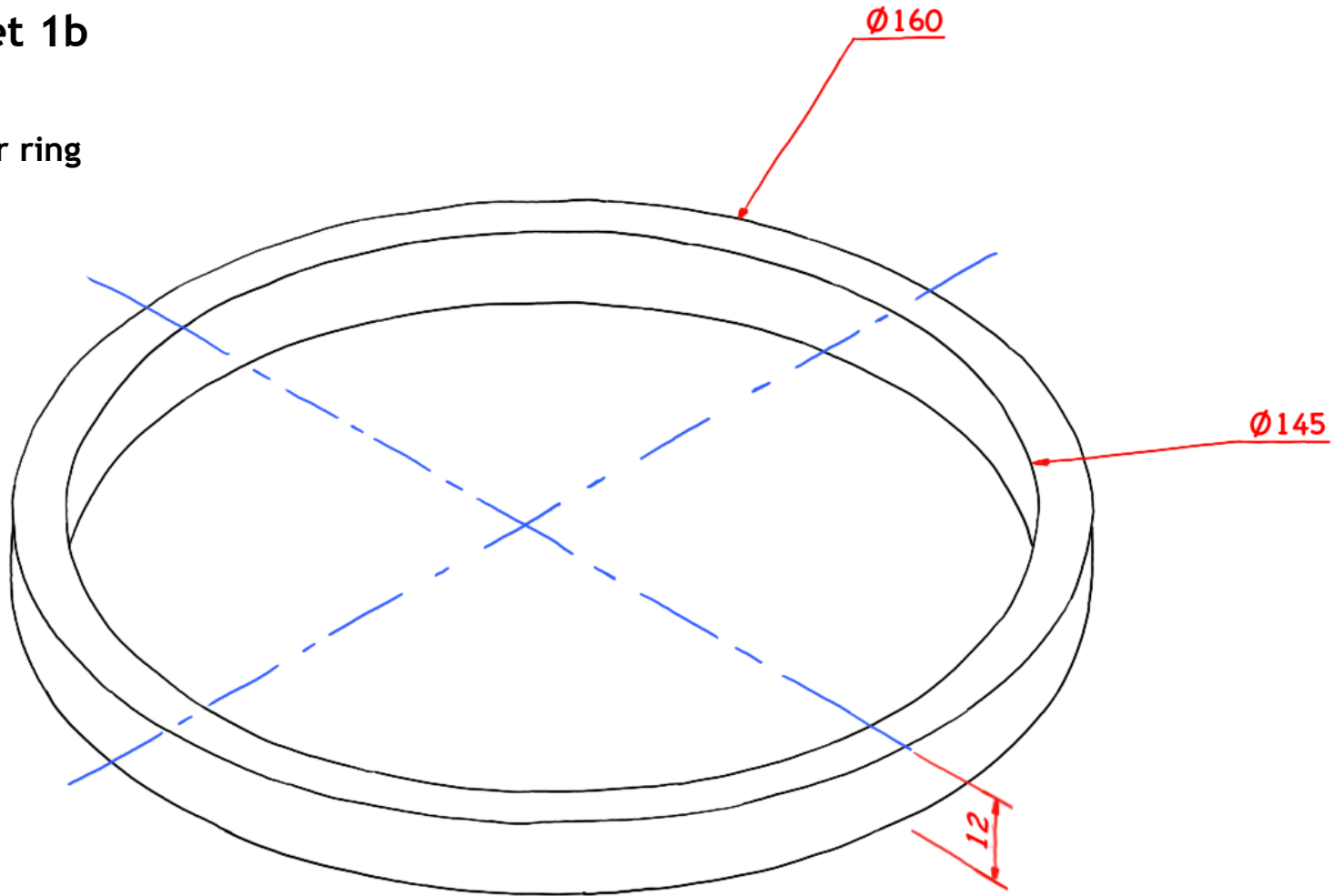

Elevation
Task 1a

Data sheet 1c

Microphone top

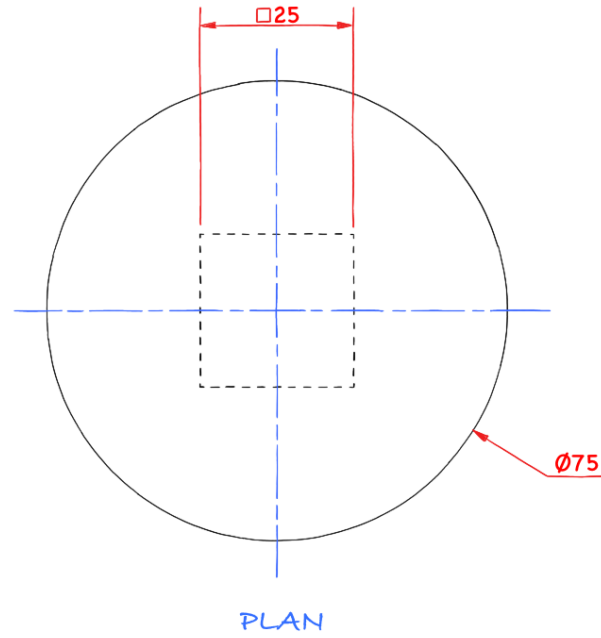

PICTORIAL VIEW

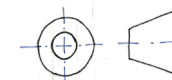
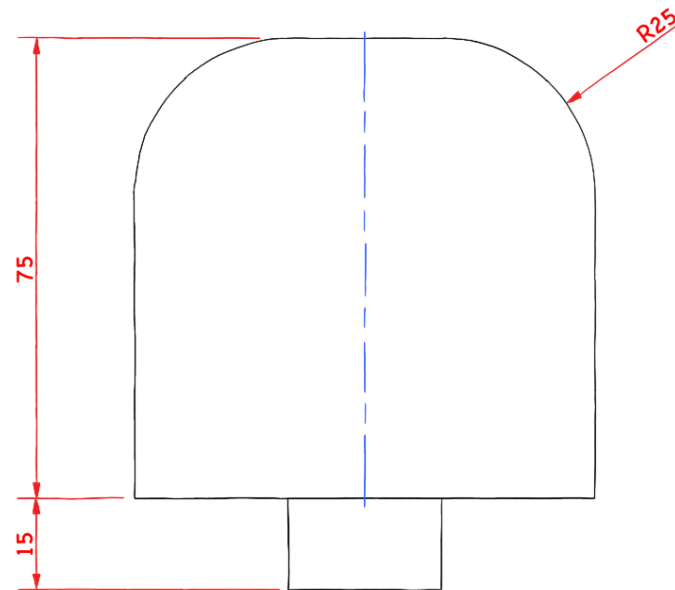

Data Sheet 1d - Microphone body

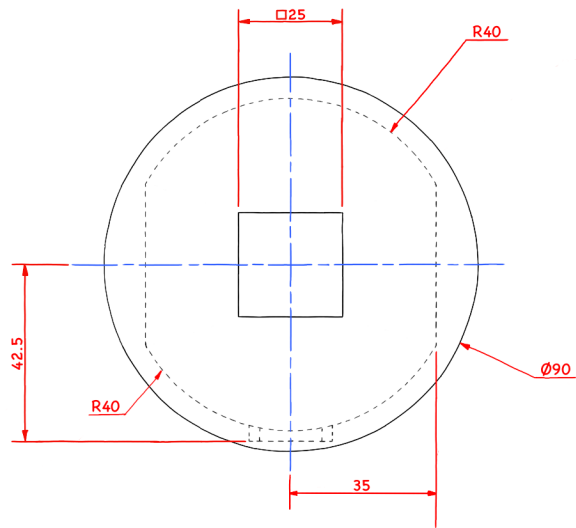

Some hidden detail removed for clarity



PICTORIAL VIEW

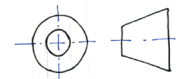
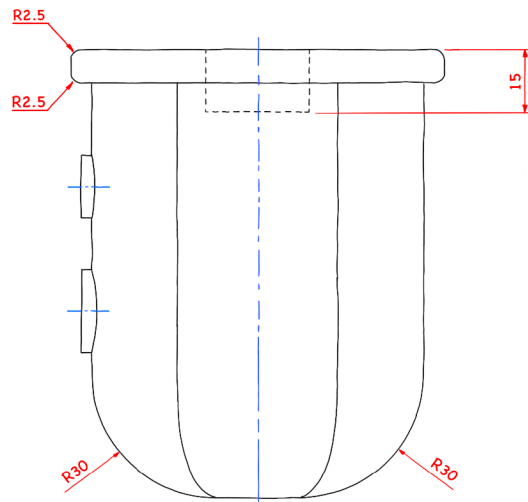
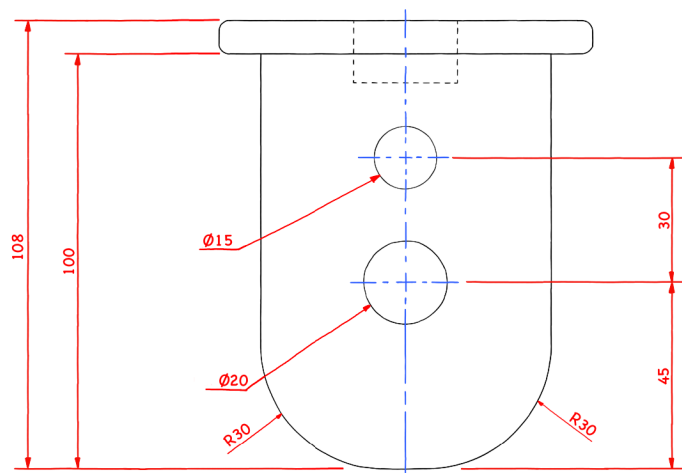

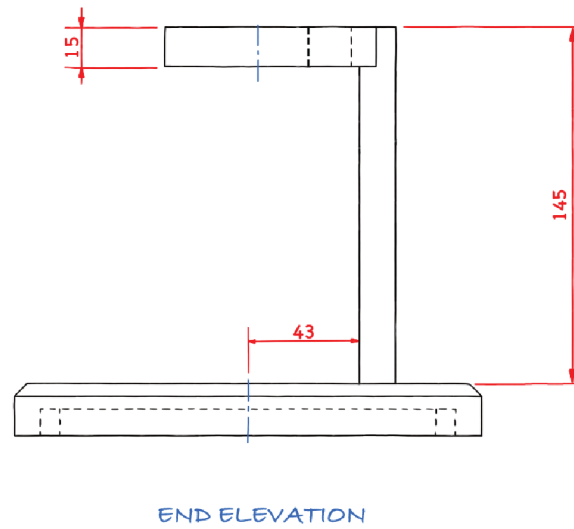
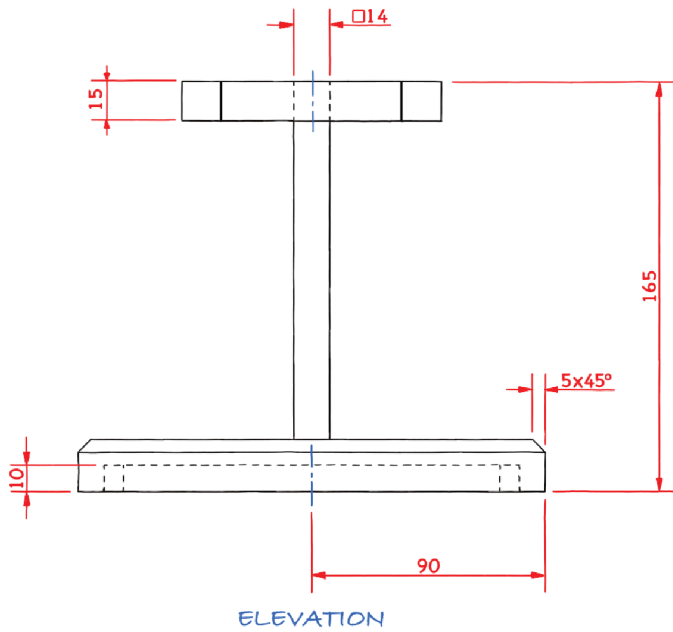
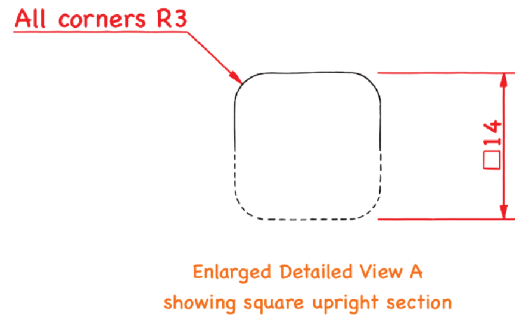
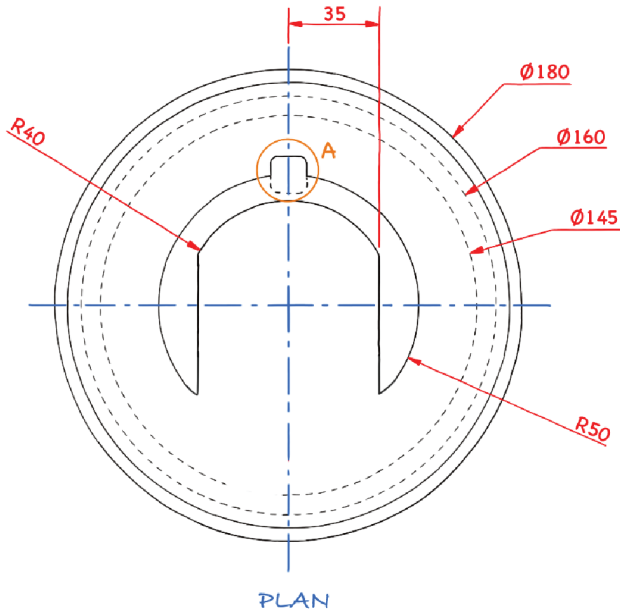

Data sheet 1e

Microphone stand

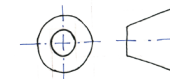

Data sheet 2a

Your promotional graphic should be a full-page advert in a magazine with dimensions 270 mm x 200 mm. Produce the graphic layout in portrait orientation, as shown in the example below.



Company name: PodSphere

You **must** use at least **one** piece of this extended text. You may use this in any format you like – it does not have to be a list.

- Elevate Your Audio Experience: The Mic That Has It All
- Intuitive Touch Controls
- Cutting-edge Technology
- Robust Metal Stand
- Enhanced Grip
- Available In A Range Of Stylish Colours

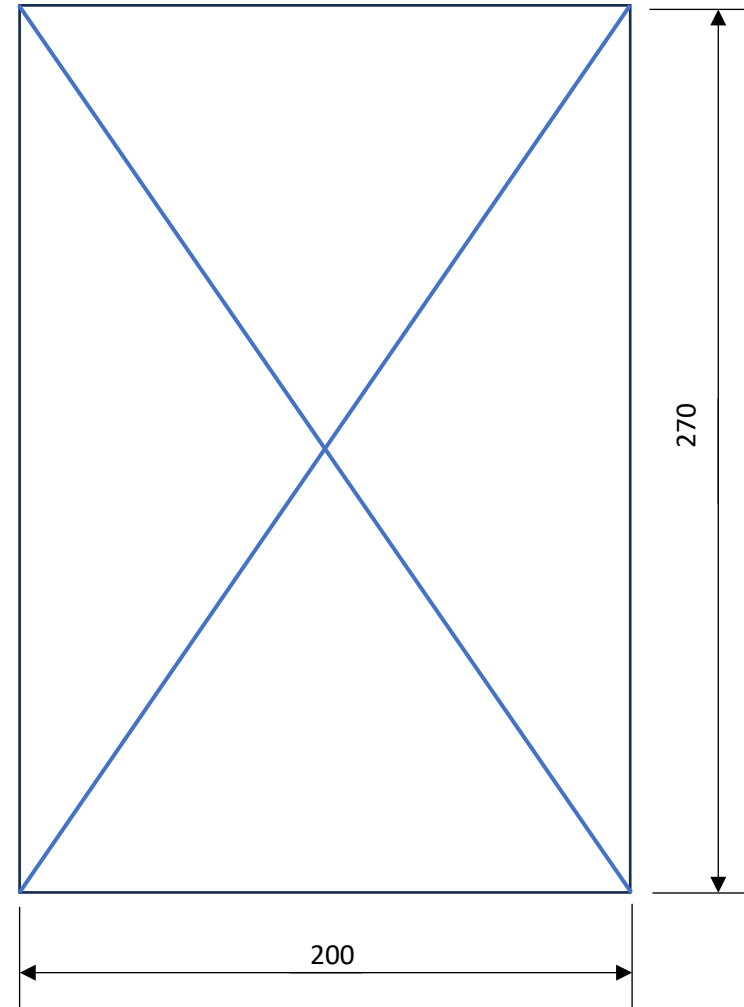

Data sheet 2b

Image 1



Image 2



Image 3

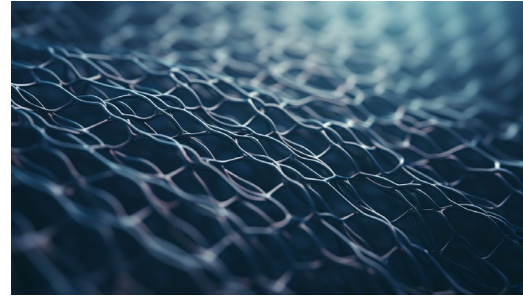

Image 4

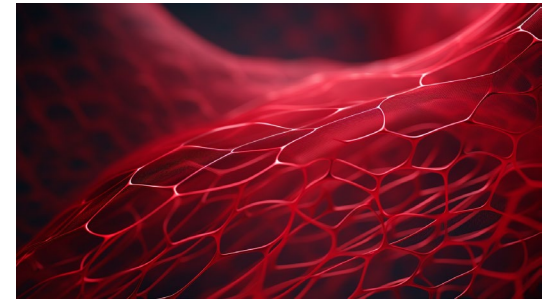

Image 5

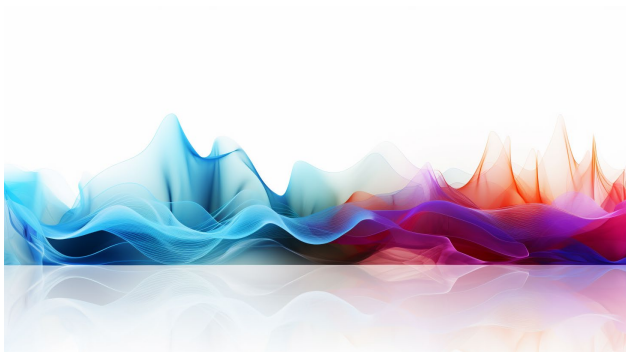

Image 6

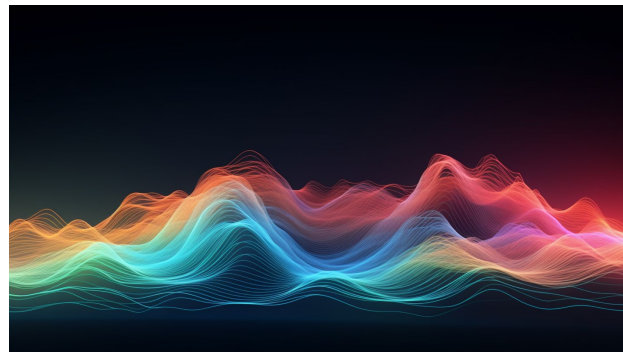
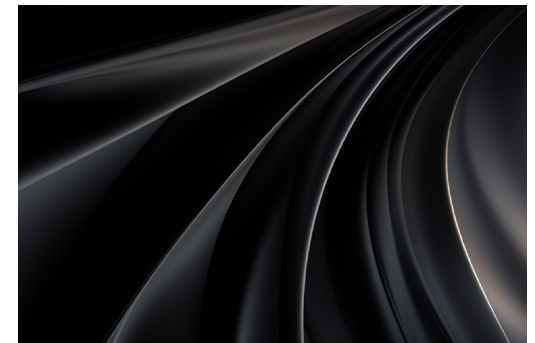

Image 7



Data sheet 2c

Image 8



Image 9



Image 10

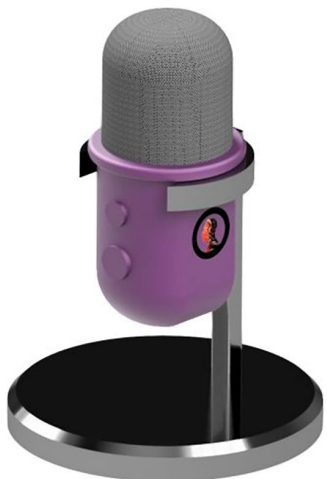

Image 11



Image 12

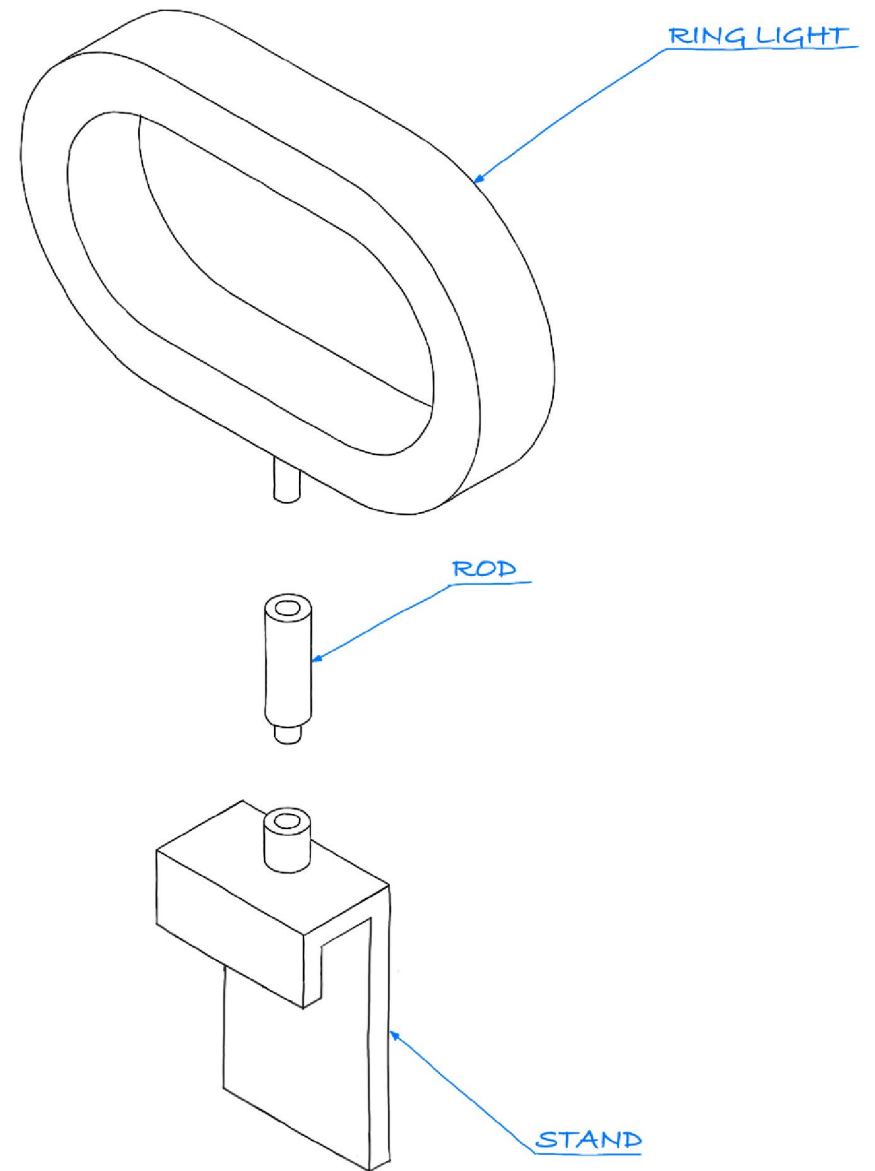
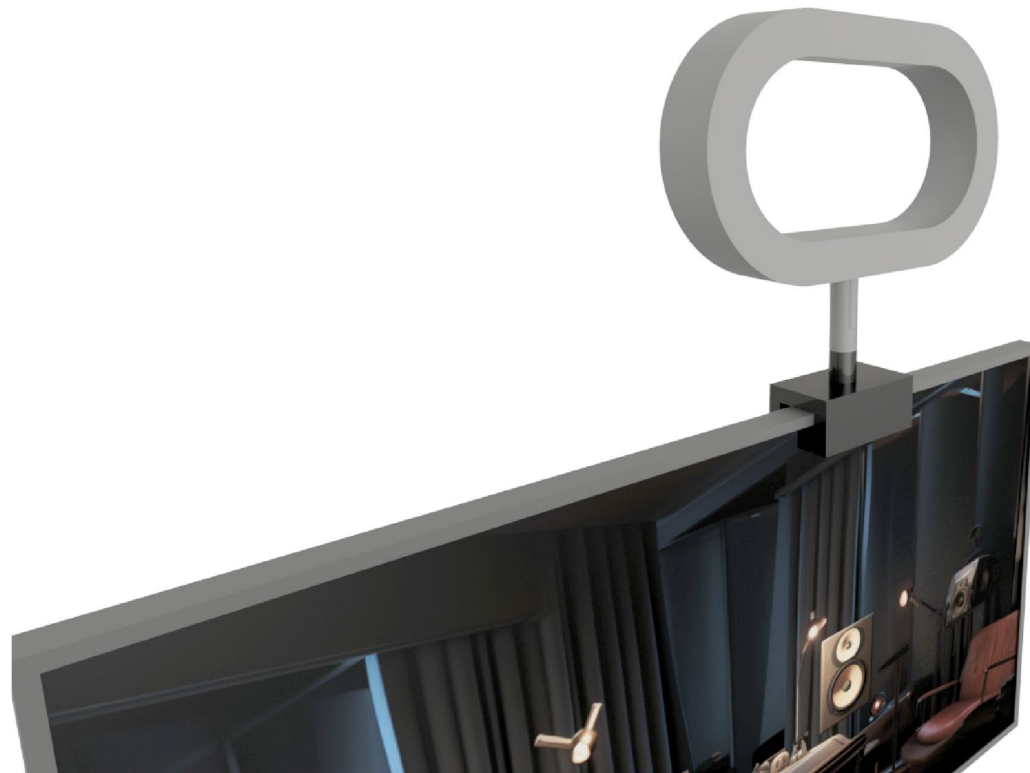

Image 13



Data sheet 3a

Rendered view of ring light and exploded pictorial view



EXPLODED PICTORIAL VIEW

Data sheet 3b

Rod

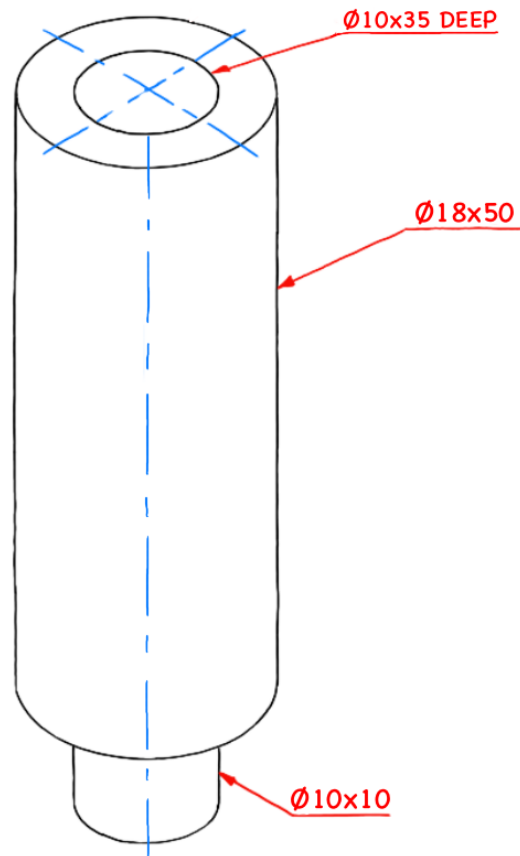

Task 3a
Elevation

PICTORIAL VIEW

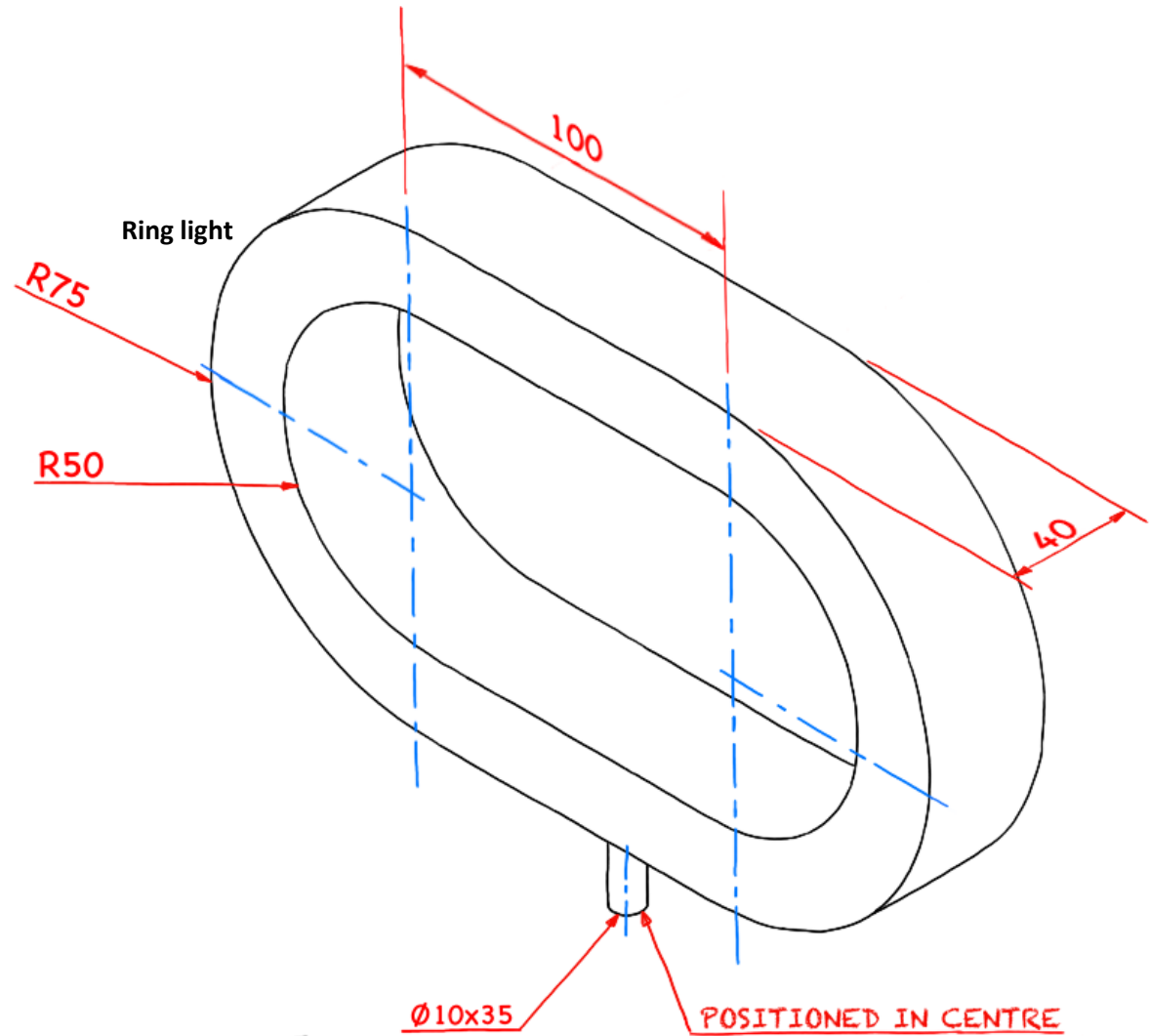

Task 3a
Elevation

PICTORIAL VIEW

Data sheet 3c

Stand

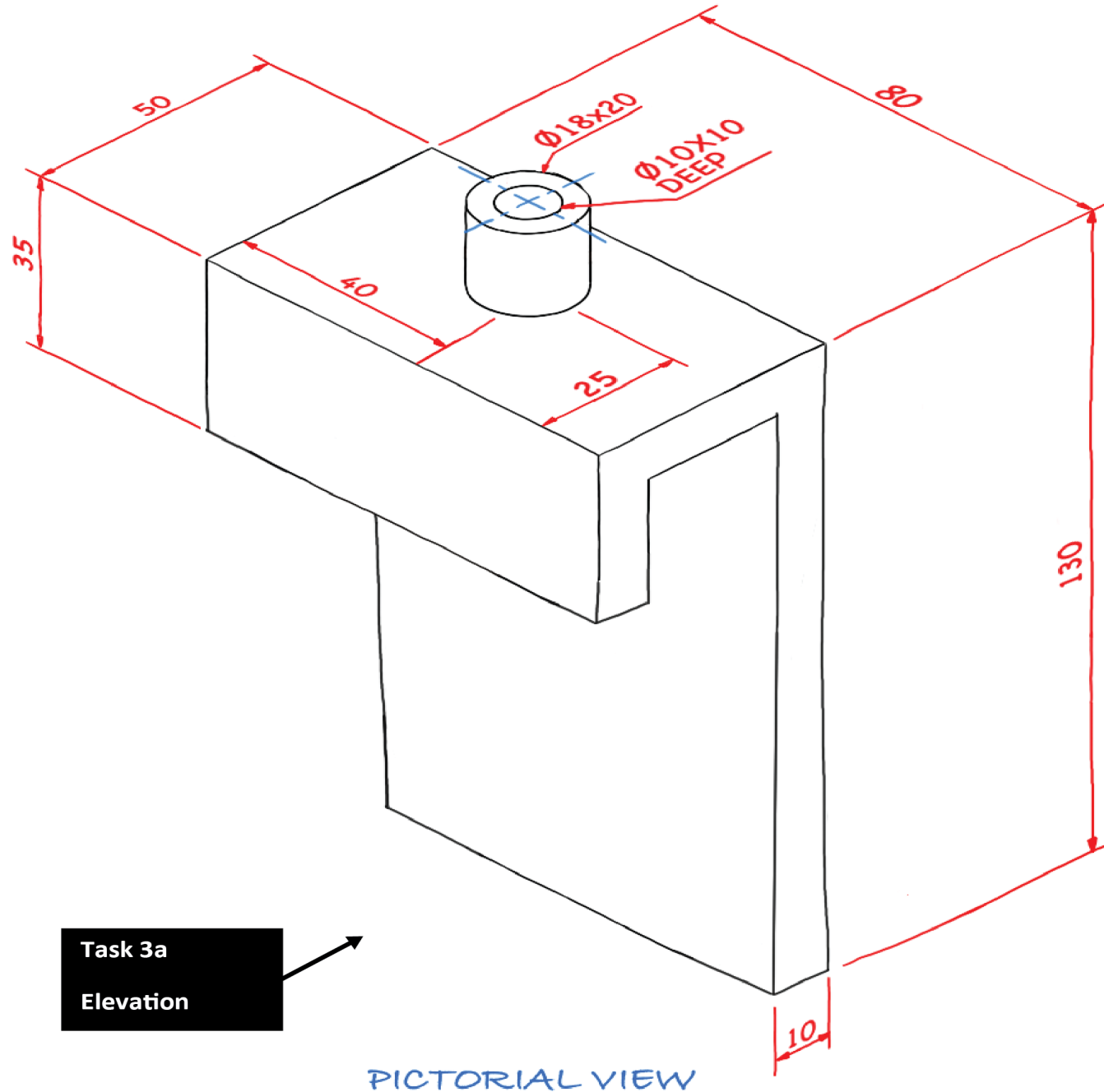

Image Descriptions

Image 1 - silhouette of people

Image 2 - woman surrounded by music

Image 3 - blue-grey mesh

Image 4 - red mesh

Image 5 - coloured sound wave on white background

Image 6 - coloured sound waves with black background

Image 7 - black wavy background

Image 8 - dark podcast set-up

Image 9 - light podcasting set-up

Image 10 - purple microphone

Image 11 - orange microphone

Image 12 - green microphone

Image 13 - headphones colour splashed

Copyright acknowledgements

Administrative information

Published: January 2025 (version 1.2)

History of changes

Version	Description of change	Date
1.1	Task 1a - amend to format of task. Data sheet 1d - updated views of microphone body. Data sheet 1e - amend to the elevation and end elevation for clarification.	15/1/25
1.2	Task 3b - amend to 2nd sentence. Reference to charging station removed.	23/1/25

Security and confidentiality

This document can be used by SQA approved centres for the assessment of National Courses and not for any other purpose.

This document may only be downloaded from SQA's designated secure website by authorised personnel.

© Scottish Qualifications Authority 2024