

FOR OFFICIAL USE



National
Qualifications
2014

Mark

X747/75/02

**Mathematics
Paper 2**

TUESDAY, 06 MAY
10:20 AM – 11:50 AM



Fill in these boxes and read what is printed below.

Full name of centre

Town

Forename(s)

Surname

Number of seat

Date of birth

Day

Month

Year

Scottish candidate number

Total marks — 50

Attempt ALL questions.

Write your answers clearly in the spaces provided in this booklet. Additional space for answers is provided at the end of this booklet. If you use this space you must clearly identify the question number you are attempting.

Use **blue** or **black** ink.

You may use a calculator.

Full credit will be given only to solutions which contain appropriate working.

State the units for your answer where appropriate.

Before leaving the examination room you must give this booklet to the Invigilator; if you do not, you may lose all the marks for this paper.



FORMULAE LIST

The roots of $ax^2 + bx + c = 0$ are $x = \frac{-b \pm \sqrt{(b^2 - 4ac)}}{2a}$

Sine rule: $\frac{a}{\sin A} = \frac{b}{\sin B} = \frac{c}{\sin C}$

Cosine rule: $a^2 = b^2 + c^2 - 2bc \cos A$ or $\cos A = \frac{b^2 + c^2 - a^2}{2bc}$

Area of a triangle: $A = \frac{1}{2} ab \sin C$

Volume of a sphere: $V = \frac{4}{3} \pi r^3$

Volume of a cone: $V = \frac{1}{3} \pi r^2 h$

Volume of a pyramid: $V = \frac{1}{3} Ah$

Standard deviation: $s = \sqrt{\frac{\Sigma(x - \bar{x})^2}{n-1}} = \sqrt{\frac{\Sigma x^2 - (\Sigma x)^2/n}{n-1}}$, where n is the sample size.



* X 7 4 7 7 5 0 2 0 2 *

MARKS

DO NOT
WRITE IN
THIS
MARGIN

1. There are 964 pupils on the roll of Aberleven High School.
It is forecast that the roll will decrease by 15% per year.
What will be the expected roll after 3 years?
Give your answer to the nearest ten.

3

[Turn over



* X 7 4 7 7 5 0 2 0 3 *

MARKS

DO NOT
WRITE IN
THIS
MARGIN

2. The diagram shows a cube placed on top of a cuboid, relative to the coordinate axes.

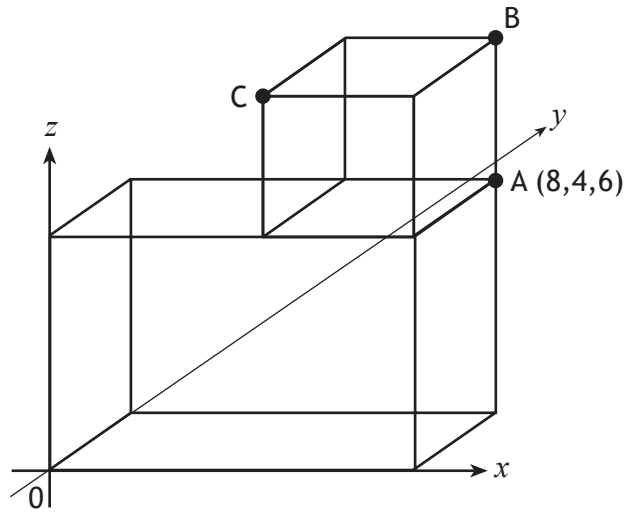

A is the point $(8, 4, 6)$.

Write down the coordinates of B and C.

2



MARKS DO NOT
WRITE IN
THIS
MARGIN

3. Two groups of people go to a theatre.

Bill buys tickets for 5 adults and 3 children.

The total cost of his tickets is £158.25.

(a) Write down an equation to illustrate this information.

1

(b) Ben buys tickets for 3 adults and 2 children.

The total cost of his tickets is £98.

Write down an equation to illustrate this information.

1

(c) Calculate the cost of a ticket for an adult and the cost of a ticket for a child.

4

Total marks 6

[Turn over



MARKS

DO NOT
WRITE IN
THIS
MARGIN

4. A runner has recorded her times, in seconds, for six different laps of a running track.

53 57 58 60 55 56

- (a) (i) Calculate the mean of these lap times.
Show clearly all your working.

1

- (ii) Calculate the standard deviation of these lap times.
Show clearly all your working.

3



MARKS

DO NOT
WRITE IN
THIS
MARGIN

4. (continued)

(b) She changes her training routine hoping to improve her consistency.

After this change, she records her times for another six laps.

The mean is 55 seconds and the standard deviation 3.2 seconds.

Has the new training routine improved her consistency?

Give a reason for your answer.

1

Total marks 5

[Turn over



* X 7 4 7 7 5 0 2 0 7 *

MARKS

DO NOT
WRITE IN
THIS
MARGIN

5. A supermarket sells cylindrical cookie jars which are mathematically similar.

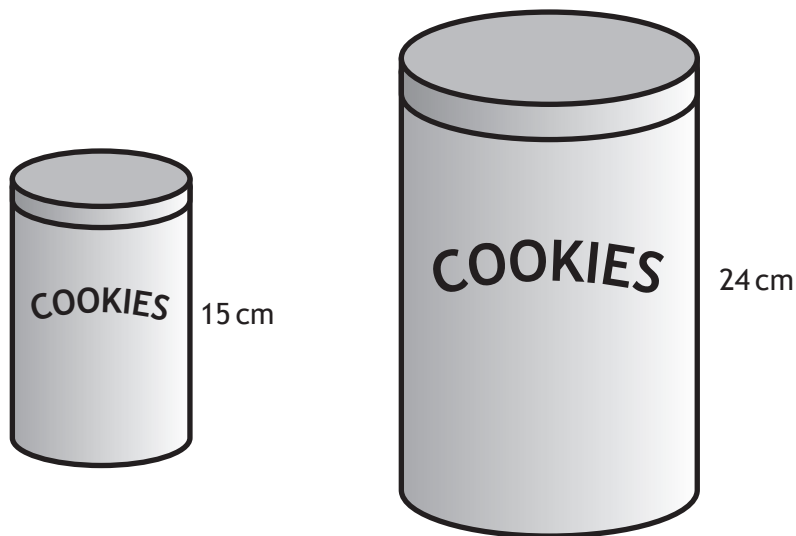

The smaller jar has a height of 15 centimetres and a volume of 750 cubic centimetres.

The larger jar has a height of 24 centimetres.

Calculate the volume of the larger jar.

3



6. The diagram below shows the position of three towns.
Lowtown is due west of Midtown.
The distance from

- Lowtown to Midtown is 75 kilometres.
- Midtown to Hightown is 110 kilometres.
- Hightown to Lowtown is 85 kilometres.

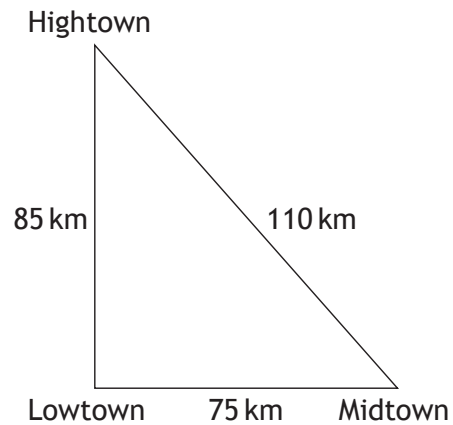

Is Hightown directly north of Lowtown?

Justify your answer.

4

[Turn over



* X 7 4 7 7 5 0 2 0 9 *

MARKS

DO NOT
WRITE IN
THIS
MARGIN

7. An ornament is in the shape of a cone with diameter 8 centimetres and height 15 centimetres.

The bottom contains a hemisphere made of copper with diameter 7.4 centimetres. The rest is made of glass, as shown in the diagram below.

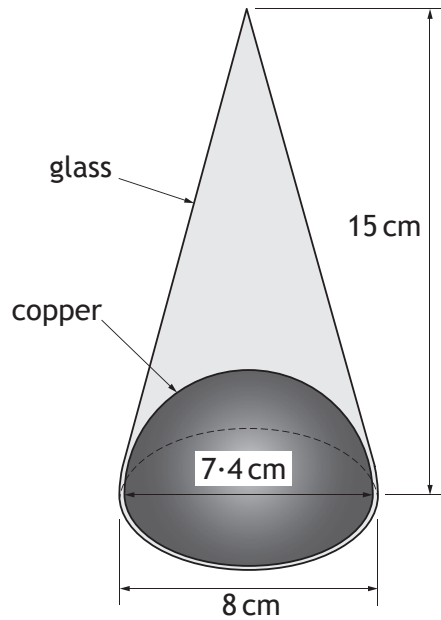

Calculate the volume of the glass part of the ornament.

Give your answer correct to 2 significant figures.

5



8. Simplify $\frac{n^5 \times 10n}{2n^2}$.

MARKS

DO NOT
WRITE IN
THIS
MARGIN

3

9. Express $\frac{7}{x+5} - \frac{3}{x}$ $x \neq -5, x \neq 0$ as a single fraction in its simplest form.

3

[Turn over



* X 7 4 7 7 5 0 2 1 1 *

MARKS

DO NOT
WRITE IN
THIS
MARGIN

10. In a race, boats sail round three buoys represented by A, B, and C in the diagram below.

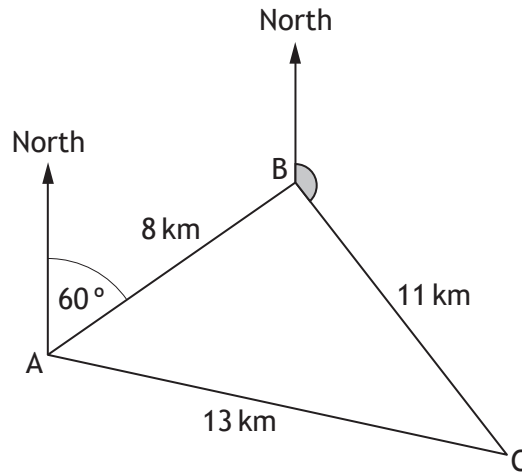

B is 8 kilometres from A on a bearing of 060° .

C is 11 kilometres from B.

A is 13 kilometres from C.

- (a) Calculate the size of angle ABC.

3

- (b) Hence find the size of the shaded angle.

2

Total marks 5



MARKS

DO NOT
WRITE IN
THIS
MARGIN

11. Change the subject of the formula $s = ut + \frac{1}{2}at^2$ to a .

3

12. Solve the equation $11\cos x^\circ - 2 = 3$, for $0 \leq x \leq 360$.

3

[Turn over



* X 7 4 7 7 5 0 2 1 3 *

13. The picture shows the entrance to a tunnel which is in the shape of part of a circle.

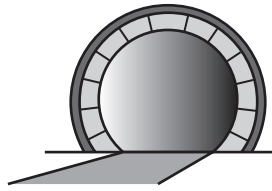

The diagram below represents the cross-section of the tunnel.

- The centre of the circle is O.
- MN is a chord of the circle.
- Angle MON is 50° .
- The radius of the circle is 7 metres.

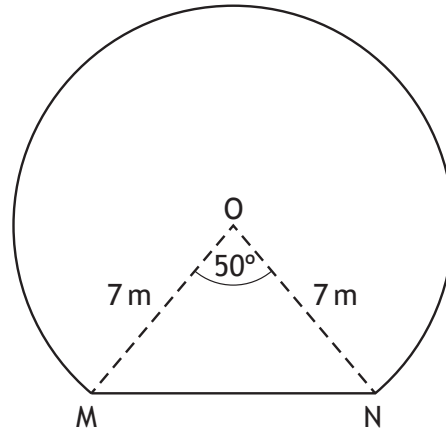

Calculate the area of the cross-section of the tunnel.

5

[END OF QUESTION PAPER]





ADDITIONAL SPACE FOR ANSWERS

MARKS

DO NOT
WRITE IN
THIS
MARGIN

--



* X 7 4 7 7 5 0 2 1 5 *

ADDITIONAL SPACE FOR ANSWERS

MARKS

DO NOT
WRITE IN
THIS
MARGIN



* X 7 4 7 7 5 0 2 1 6 *