

FOR OFFICIAL USE



National  
Qualifications  
2017

Mark

**X747/75/02**

**Mathematics  
Paper 2**

FRIDAY, 5 MAY

2:20 PM – 3:50 PM



\* X 7 4 7 7 5 0 2 \*

Fill in these boxes and read what is printed below.

Full name of centre

Town

Forename(s)

Surname

Number of seat

Date of birth

Day

Month

Year

Scottish candidate number

**Total marks — 50**

Attempt ALL questions.

**You may use a calculator.**

Full credit will be given only to solutions which contain appropriate working.

State the units for your answer where appropriate.

Write your answers clearly in the spaces provided in this booklet. Additional space for answers is provided at the end of this booklet. If you use this space you must clearly identify the question number you are attempting.

Use **blue** or **black** ink.

Before leaving the examination room you must give this book to the Invigilator; if you do not, you may lose all the marks for this paper.



\* X 7 4 7 7 5 0 2 0 1 \*

## FORMULAE LIST

The roots of  $ax^2 + bx + c = 0$  are  $x = \frac{-b \pm \sqrt{(b^2 - 4ac)}}{2a}$

Sine rule:  $\frac{a}{\sin A} = \frac{b}{\sin B} = \frac{c}{\sin C}$

Cosine rule:  $a^2 = b^2 + c^2 - 2bc \cos A$  or  $\cos A = \frac{b^2 + c^2 - a^2}{2bc}$

Area of a triangle:  $A = \frac{1}{2}ab \sin C$

Volume of a sphere:  $V = \frac{4}{3}\pi r^3$

Volume of a cone:  $V = \frac{1}{3}\pi r^2 h$

Volume of a pyramid:  $V = \frac{1}{3}Ah$

Standard deviation:  $s = \sqrt{\frac{\Sigma(x - \bar{x})^2}{n - 1}}$

or  $s = \sqrt{\frac{\Sigma x^2 - \frac{(\Sigma x)^2}{n}}{n - 1}}$ , where  $n$  is the sample size.



\* X 7 4 7 7 5 0 2 0 2 \*

MARKS

DO NOT  
WRITE IN  
THIS  
MARGIN

Total marks — 50  
Attempt ALL questions

1. Find  $|\mathbf{v}|$ , the magnitude of vector  $\mathbf{v} = \begin{pmatrix} 18 \\ -14 \\ 3 \end{pmatrix}$ .

2

2. A necklace is valued at £1200.  
Its value is expected to increase by 4.5% per year over the next 3 years.  
Calculate the expected value of the necklace after this time.  
Give your answer to the nearest pound.

3

[Turn over



\* X 7 4 7 7 5 0 2 0 3 \*

3. A piece of land is in the shape of a triangle as shown.

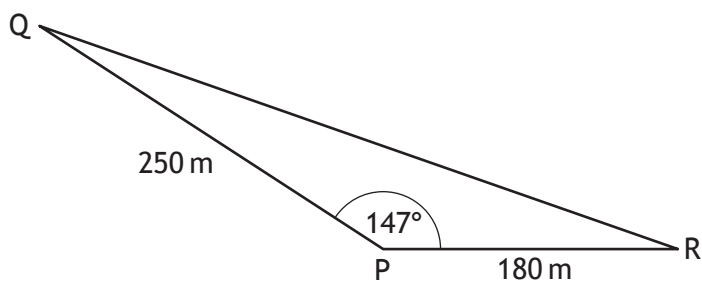

- $PQ = 250$  metres
- $PR = 180$  metres
- angle  $QPR = 147^\circ$

The owner wishes to build a fence along the side QR.  
Calculate the length of the fence.

3



MARKS

DO NOT  
WRITE IN  
THIS  
MARGIN

4. Solve the equation  $2x^2 + 5x - 4 = 0$ .  
Give your answers correct to one decimal place.

3

5. A theatre group sold 4830 tickets for their show.  
This was 15% more than they sold last year.  
How many tickets did they sell last year?

3

[Turn over



\* X 7 4 7 7 5 0 2 0 5 \*

6. A spherical sweet is made by coating a caramel sphere evenly with chocolate. A cross-section of the sweet is shown below.

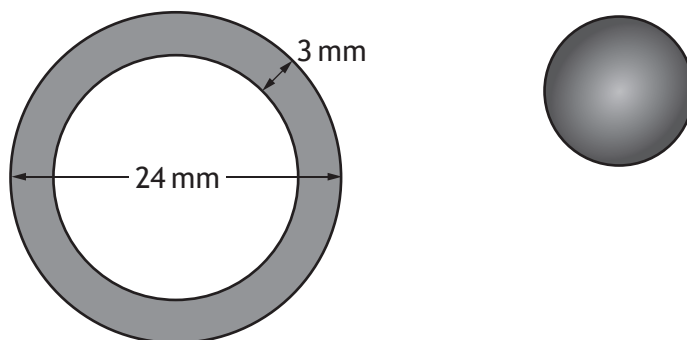

The diameter of the sweet is 24 millimetres and the thickness of the chocolate coating is 3 millimetres.

Calculate the volume of the chocolate coating.

Give your answer correct to 3 significant figures.

5



7. Triangles A and B are shown below.

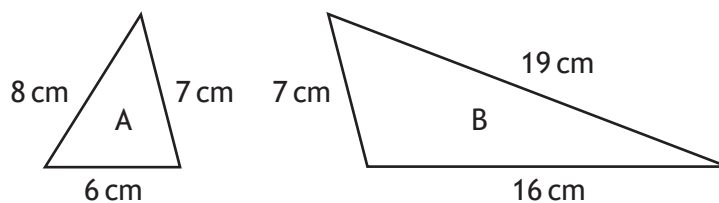

The triangles are placed together to form the larger triangle shown below.

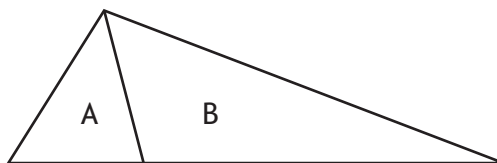

Is this larger triangle right-angled?

Justify your answer.

3

[Turn over



\* X 7 4 7 7 5 0 2 0 7 \*

8. In the diagram below,  $\vec{RQ}$  and  $\vec{PQ}$  represent the vectors  $\mathbf{c}$  and  $\mathbf{d}$  respectively.

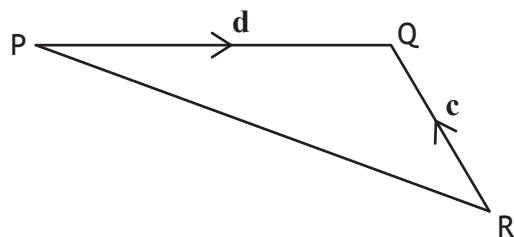

(a) Express  $\vec{PR}$  in terms of  $\mathbf{c}$  and  $\mathbf{d}$ .

1

The line QP is extended to T.

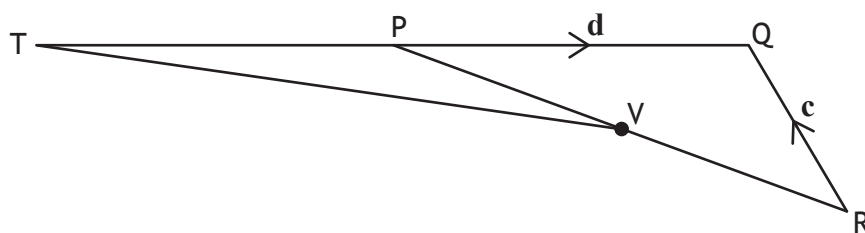

- $TP = PQ$
- V is the midpoint of PR

(b) Express  $\vec{TV}$  in terms of  $\mathbf{c}$  and  $\mathbf{d}$ .  
Give your answer in simplest form.

2



MARKS

DO NOT  
WRITE IN  
THIS  
MARGIN

9. (a) Factorise  $4x^2 - 25$ .

1

(b) Hence simplify  $\frac{4x^2 - 25}{2x^2 - x - 10}$ .

3

[Turn over



\* X 7 4 7 7 5 0 2 0 9 \*

10. In the diagram below D, E and F represent the positions of Dunbridge, Earlsford and Fairtown respectively.

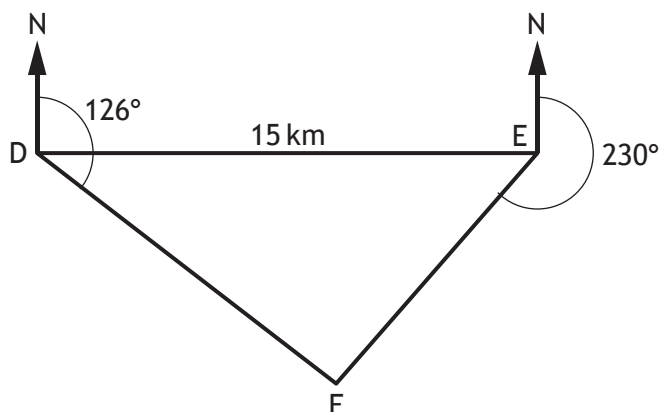

Dunbridge is 15 kilometres west of Earlsford.

From Dunbridge, the bearing of Fairtown is  $126^\circ$ .

From Earlsford the bearing of Fairtown is  $230^\circ$ .

Calculate the distance between Dunbridge and Fairtown.

Do not use a scale drawing.

4



MARKS

DO NOT  
WRITE IN  
THIS  
MARGIN

11. A straight line has equation  $3x - 5y - 10 = 0$ .  
Find the gradient of this line.

2

12. Express  $\frac{1}{\sqrt[3]{x}}$  in the form  $x^n$ .

2

[Turn over



\* X 7 4 7 7 5 0 2 1 1 \*

13. Two identical shapes are used to form a logo.  
Each shape is part of a circle.

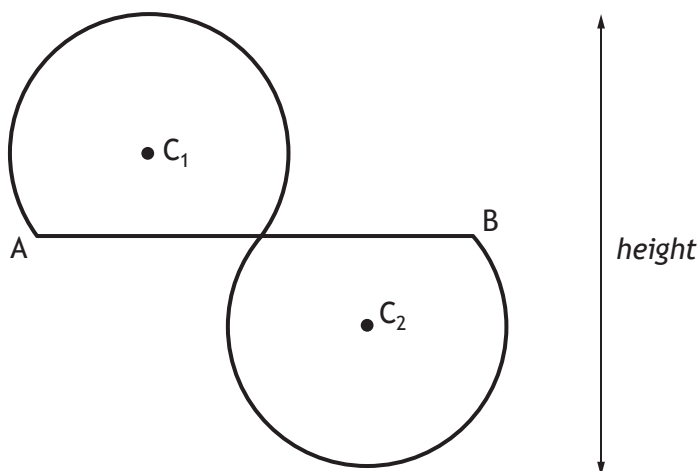

- The circles have centres  $C_1$  and  $C_2$ .
- The radius of each circle is 14 centimetres.
- The logo has half-turn symmetry about the mid-point of AB.
- AB is 48 centimetres long.

Calculate the height of the logo.

4



MARKS

DO NOT  
WRITE IN  
THIS  
MARGIN

14. The diagram below shows part of a circle, centre O.

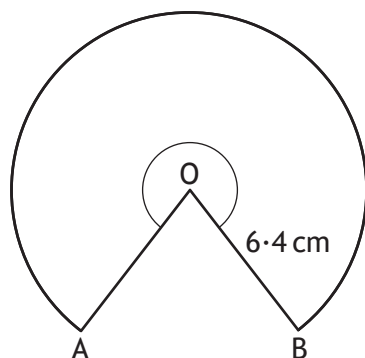

The radius of the circle is 6.4 centimetres.  
Major arc AB has length 31.5 centimetres.  
Calculate the size of the reflex angle AOB.

3

[Turn over



\* X 7 4 7 7 5 0 2 1 3 \*

15. A wind turbine has three blades as shown below.

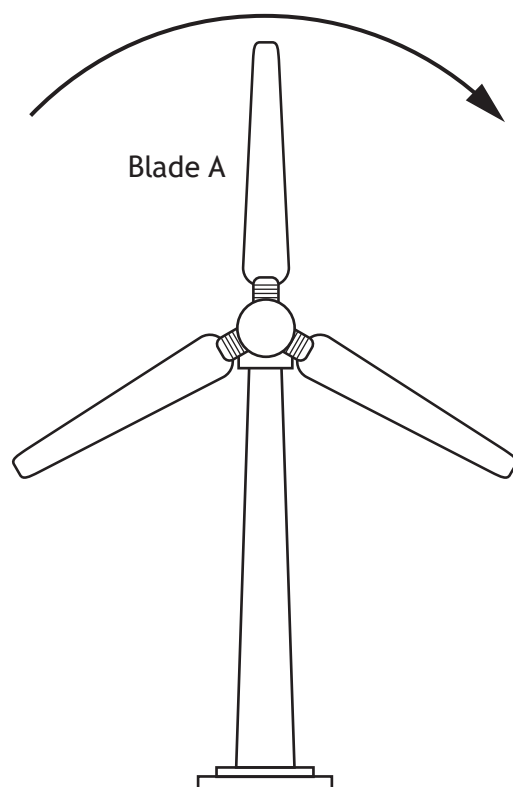

The height,  $h$  metres, of the tip of blade A above the ground in each rotation is given by

$$h = 40 + 23 \cos x^\circ, \quad 0 \leq x < 360$$

where  $x$  is the angle blade A has turned clockwise from its vertical position.

- (a) Calculate the height of the tip of blade A after it has turned through an angle of  $60^\circ$ .

1



MARKS

DO NOT  
WRITE IN  
THIS  
MARGIN

15. (continued)

(b) Find the minimum height of the tip of blade A above the ground.

1

(c) Calculate the values of  $x$  for which the tip of blade A is 61 metres above the ground.

4

[END OF QUESTION PAPER]



\* X 7 4 7 7 5 0 2 1 5 \*

MARKS

DO NOT  
WRITE IN  
THIS  
MARGIN

ADDITIONAL SPACE FOR ANSWERS



\* X 7 4 7 7 5 0 2 1 6 \*

MARKS

DO NOT  
WRITE IN  
THIS  
MARGIN

ADDITIONAL SPACE FOR ANSWERS



\* X 7 4 7 7 5 0 2 1 7 \*

MARKS

DO NOT  
WRITE IN  
THIS  
MARGIN

ADDITIONAL SPACE FOR ANSWERS



\* X 7 4 7 7 5 0 2 1 8 \*

MARKS

DO NOT  
WRITE IN  
THIS  
MARGIN

ADDITIONAL SPACE FOR ANSWERS



\* X 7 4 7 7 5 0 2 1 9 \*

MARKS

DO NOT  
WRITE IN  
THIS  
MARGIN

ADDITIONAL SPACE FOR ANSWERS



\* X 7 4 7 7 5 0 2 2 0 \*