

FOR OFFICIAL USE



National
Qualifications
2018

Mark

X847/75/02

**Mathematics
Paper 2**

FRIDAY, 4 MAY

10:35 AM – 12:25 PM



* X 8 4 7 7 5 0 2 *

Fill in these boxes and read what is printed below.

Full name of centre

Town

Forename(s)

Surname

Number of seat

Date of birth

Day

Month

Year

Scottish candidate number

Total marks — 60

Attempt ALL questions.

You may use a calculator.

To earn full marks you must show your working in your answers.

State the units for your answer where appropriate.

Write your answers clearly in the spaces provided in this booklet. Additional space for answers is provided at the end of this booklet. If you use this space you must clearly identify the question number you are attempting.

Use **blue** or **black** ink.

Before leaving the examination room you must give this booklet to the Invigilator; if you do not, you may lose all the marks for this paper.



* X 8 4 7 7 5 0 2 0 1 *

FORMULAE LIST

The roots of $ax^2 + bx + c = 0$ are $x = \frac{-b \pm \sqrt{b^2 - 4ac}}{2a}$

Sine rule: $\frac{a}{\sin A} = \frac{b}{\sin B} = \frac{c}{\sin C}$

Cosine rule: $a^2 = b^2 + c^2 - 2bc \cos A$ or $\cos A = \frac{b^2 + c^2 - a^2}{2bc}$

Area of a triangle: $A = \frac{1}{2}ab \sin C$

Volume of a sphere: $V = \frac{4}{3}\pi r^3$

Volume of a cone: $V = \frac{1}{3}\pi r^2 h$

Volume of a pyramid: $V = \frac{1}{3}Ah$

Standard deviation: $s = \sqrt{\frac{\sum(x - \bar{x})^2}{n - 1}}$

or $s = \sqrt{\frac{\sum x^2 - \frac{(\sum x)^2}{n}}{n - 1}}$, where n is the sample size.



* X 8 4 7 7 5 0 2 0 2 *

Total marks — 60
Attempt ALL questions

1. Households in a city produced a total of 125 000 tonnes of waste in 2017.
The total amount of waste is expected to fall by 2% each year.
Calculate the total amount of waste these households are expected to produce
in 2020.

3



2. The diagram below shows a sector of a circle, centre C.

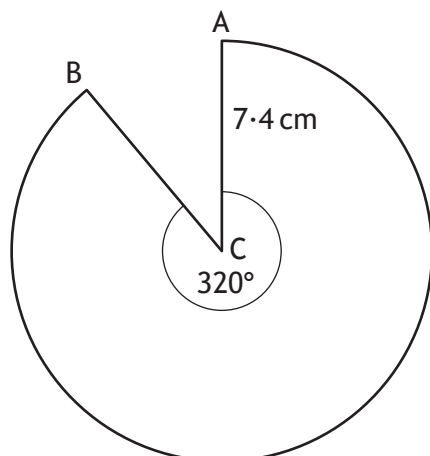

The radius of the circle is 7.4 centimetres.

Calculate the length of the major arc AB.

3



* X 8 4 7 7 5 0 2 0 4 *

MARKS

DO NOT
WRITE IN
THIS
MARGIN

3. Find $|\mathbf{r}|$, the magnitude of vector $\mathbf{r} = \begin{pmatrix} 24 \\ -12 \\ 8 \end{pmatrix}$.

2

4. Solve, algebraically, the inequation

$$3x < 6(x-1) - 12.$$

3



* X 8 4 7 7 5 0 2 0 5 *

5. A farmers' market took place one weekend.

Stallholders were asked to record the number of customers who visited their stall.

The number of customers who visited six of the stalls on Saturday were as follows:

120 126 125 131 130 124

(a) Calculate the mean and standard deviation of the number of customers. 4



5. (continued)

The mean number of customers who visited these six stalls on Sunday was 117 and the standard deviation was 6.2.

- (b) Make two valid comments comparing the number of customers who visited these stalls on Saturday and Sunday.

2

6. A function is defined as $f(x) = 5 + 4x$.

Given that $f(a) = 73$, calculate a .

2



* X 8 4 7 7 5 0 2 0 7 *

7. A toy company makes juggling balls in the shape of a sphere with a diameter of 6.4 centimetres.

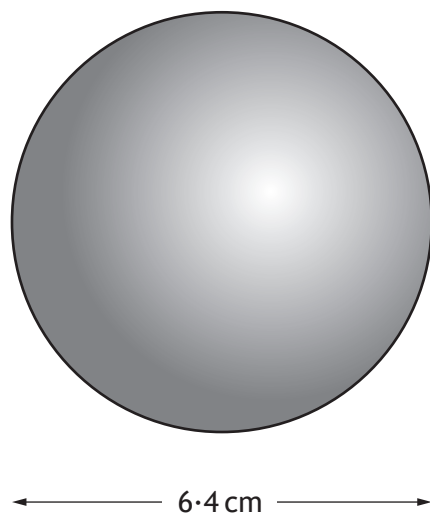

Calculate the volume of one juggling ball.
Give your answer correct to 2 significant figures.

3



MARKS

DO NOT
WRITE IN
THIS
MARGIN

8. Solve the equation $7 \sin x^\circ + 2 = 3$, for $0 \leq x < 360$.

3



* X 8 4 7 7 5 0 2 0 9 *

MARKS

DO NOT
WRITE IN
THIS
MARGIN

9. In this diagram:

- angle $ABD = 75^\circ$
- angle $BDC = 37^\circ$
- $BC = 20$ centimetres.

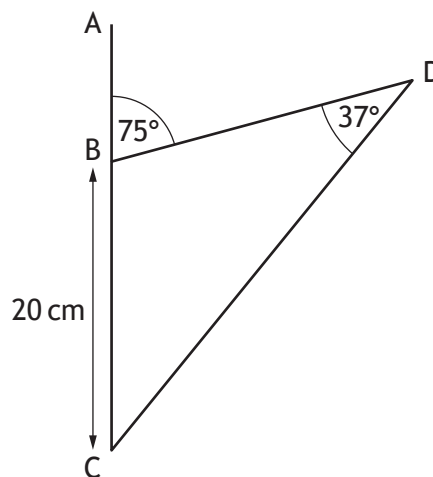

Calculate the length of DC .

3



10. In the diagram below, \vec{AB} and \vec{EA} represent the vectors \mathbf{u} and \mathbf{w} respectively.

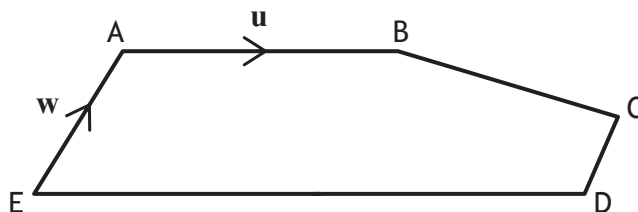

- $\vec{ED} = 2\vec{AB}$
- $\vec{EA} = 2\vec{DC}$

Express \vec{BC} in terms of \mathbf{u} and \mathbf{w} .

Give your answer in its simplest form.

2



* X 8 4 7 7 5 0 2 1 1 *

11. Venus and Earth are two planets within our solar system.



Venus



Earth

The volume of Venus is approximately 9.3×10^{11} cubic kilometres.

This is 85% of the volume of Earth.

Calculate the volume of Earth.

3



* X 8 4 7 7 5 0 2 1 2 *

12. The shape below is part of a circle, centre O.

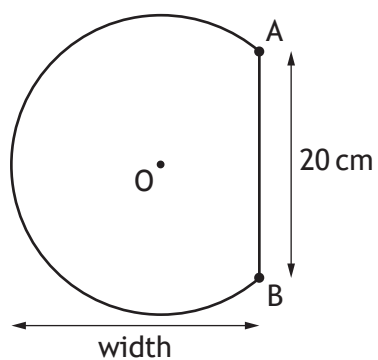

The circle has radius 13 centimetres.
AB is a chord of length 20 centimetres.
Calculate the width of the shape.

4



* X 8 4 7 7 5 0 2 1 3 *

13. A ferry and a trawler receive a request for help from a stranded yacht.
On the diagram the points F, T and Y show the positions of the ferry, the trawler and the yacht respectively.

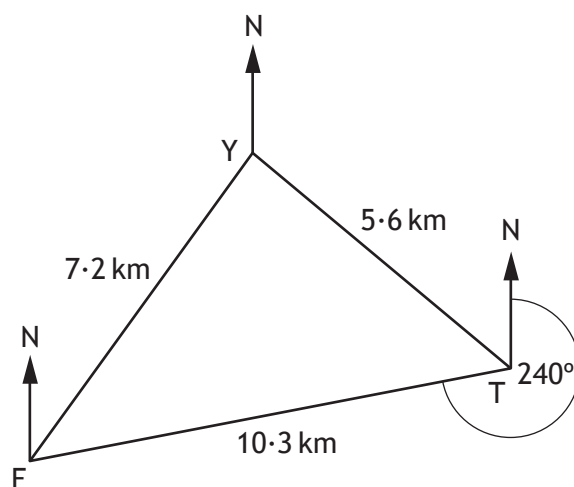

- FY is 7.2 kilometres.
- TY is 5.6 kilometres.
- FT is 10.3 kilometres.
- F is on a bearing of 240° from T.

Calculate the bearing of the yacht from the trawler.

4



MARKS

DO NOT
WRITE IN
THIS
MARGIN

14. A straight line has equation $2x - 5y = 20$.
Find the coordinates of the point where this line crosses the y -axis.

2

15. Express

$$\frac{n}{n^2 - 4} \div \frac{3}{n - 2}, \quad n \neq -2, n \neq 2$$

as a single fraction in its simplest form.

3



* X 8 4 7 7 5 0 2 1 5 *

16. Chris wants to store his umbrella in a locker.

The locker is a cuboid with internal dimensions of length 40 centimetres, breadth 40 centimetres and height 70 centimetres.

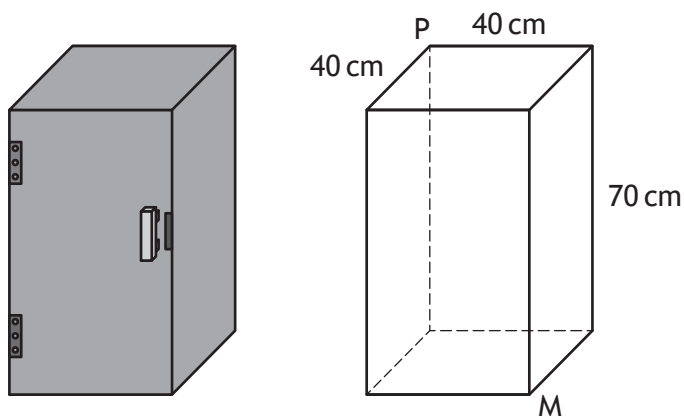

The umbrella is 85 centimetres long.

He thinks it will fit into the locker from corner P to corner M.

Is he correct?

Justify your answer.

4



* X 8 4 7 7 5 0 2 1 6 *

17. In the diagram below AOD is a sector of a circle, with centre O, and BOC is a triangle.

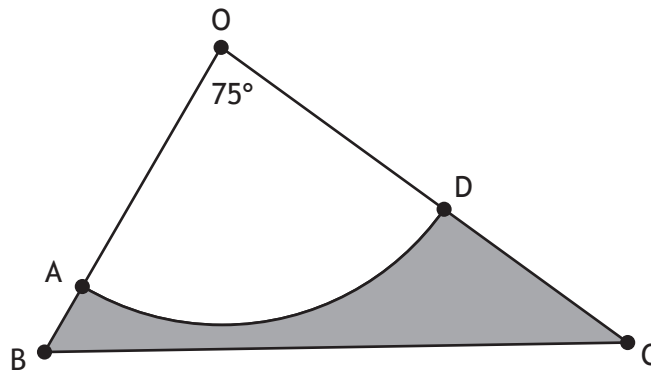

In sector AOD:

- radius = 30 centimetres
- angle AOD = 75° .

In triangle OBC:

- OB = 38 centimetres
- OC = 55 centimetres.

Calculate the area of the shaded region, ABCD.

5



* X 8 4 7 7 5 0 2 1 7 *

18. A cinema sells popcorn in two different sized cartons.



The small carton is 16 centimetres deep and has a volume of 576 cubic centimetres.

The large carton is 24 centimetres deep and has a volume of 1125 cubic centimetres.

(a) Show that the two cartons are **not** mathematically similar.

3



MARKS

DO NOT
WRITE IN
THIS
MARGIN

18. (continued)

The large carton is redesigned so that the two cartons are **now** mathematically similar.

The volume of the redesigned large carton is 1500 cubic centimetres.

(b) Calculate the depth of the redesigned large carton.

2

[END OF QUESTION PAPER]



* X 8 4 7 7 5 0 2 1 9 *

MARKS

DO NOT
WRITE IN
THIS
MARGIN

ADDITIONAL SPACE FOR ANSWERS



* X 8 4 7 7 5 0 2 2 0 *

MARKS

DO NOT
WRITE IN
THIS
MARGIN

ADDITIONAL SPACE FOR ANSWERS



* X 8 4 7 7 5 0 2 2 1 *

[BLANK PAGE]

DO NOT WRITE ON THIS PAGE



* X 8 4 7 7 5 0 2 2 2 *

[BLANK PAGE]

DO NOT WRITE ON THIS PAGE



* X 8 4 7 7 5 0 2 2 3 *

ACKNOWLEDGEMENTS

Question 11 – Venus: Dotted Yeti/Shutterstock.com

Earth: TeddyGraphics/Shutterstock.com

Question 18 – Popcorn carton: Richard Peterson/Shutterstock.com



* X 8 4 7 7 5 0 2 2 4 *