



FOR OFFICIAL USE

--	--	--	--	--	--

National
Qualifications
2023 MODIFIED

Mark

--

X847/75/02

**Mathematics
Paper 2**

WEDNESDAY, 3 MAY
10:30 AM – 12:00 NOON



Fill in these boxes and read what is printed below.

Full name of centre

--

Town

--

Forename(s)

--

Surname

--

Number of seat

--

Date of birth

Day

--	--

Month

--	--

Year

--	--

Scottish candidate number

--	--	--	--	--	--	--	--	--	--

Total marks — 50

Attempt ALL questions.

You may use a calculator.

To earn full marks you must show your working in your answers.

State the units for your answer where appropriate.

Write your answers clearly in the spaces provided in this booklet. Additional space for answers is provided at the end of this booklet. If you use this space you must clearly identify the question number you are attempting.

Use **blue** or **black** ink.

Before leaving the examination room you must give this booklet to the Invigilator; if you do not, you may lose all the marks for this paper.



FORMULAE LIST

The roots of $ax^2 + bx + c = 0$ are $x = \frac{-b \pm \sqrt{(b^2 - 4ac)}}{2a}$

Sine rule $\frac{a}{\sin A} = \frac{b}{\sin B} = \frac{c}{\sin C}$

Cosine rule $a^2 = b^2 + c^2 - 2bc \cos A$ or $\cos A = \frac{b^2 + c^2 - a^2}{2bc}$

Area of a triangle $A = \frac{1}{2}ab \sin C$

Volume of a sphere $V = \frac{4}{3}\pi r^3$

Volume of a cone $V = \frac{1}{3}\pi r^2 h$

Volume of a pyramid $V = \frac{1}{3}Ah$

Standard deviation $s = \sqrt{\frac{\Sigma(x - \bar{x})^2}{n - 1}}$

or $s = \sqrt{\frac{\Sigma x^2 - \frac{(\Sigma x)^2}{n}}{n - 1}}$, where n is the sample size.



* X 8 4 7 7 5 0 2 0 2 *

Total marks — 50
Attempt ALL questions

1. A caravan was bought for £20,000.
It depreciated by 11% in the first year.
It then depreciated by a further 6% each year over the next two years.
Calculate the value of the caravan three years after it was bought. 3

2. The mass of a helium atom is 6.64×10^{-24} grams.
A flask contains 300 grams of helium.
Calculate the number of helium atoms in this flask.
Give your answer in scientific notation, correct to 3 significant figures. 3

[Turn over



* X 8 4 7 7 5 0 2 0 3 *

3. The diagram shows part of a football pitch.

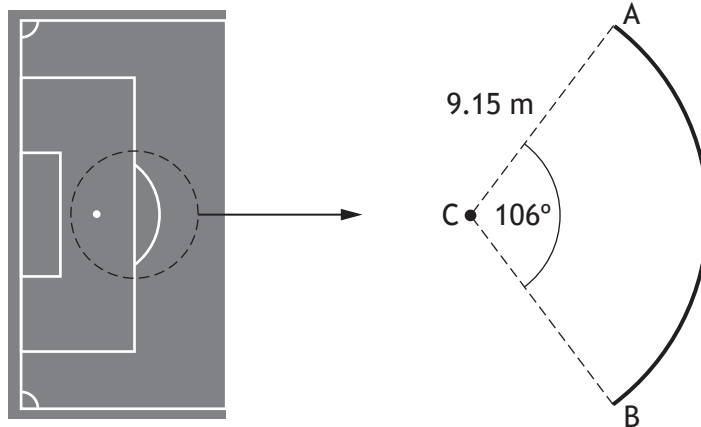

The penalty spot is marked at point C.
 AB is an arc of a circle, centre C, radius 9.15 metres.
 Calculate the length of the arc AB.

3



4. The diagram shows triangle JKL.

- Angle KJL = 25°
- JL = 10 metres
- KL = 7 metres

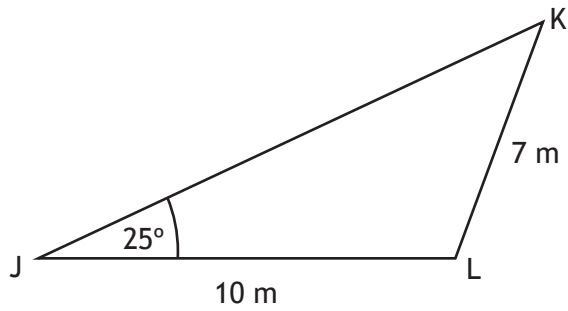

Calculate the size of angle JKL.

3

[Turn over



5. A logo consists of an H shape and a regular decagon.
The diagram represents the logo.

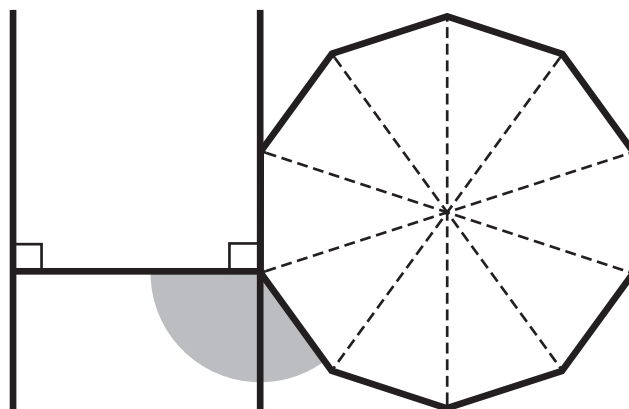

Calculate the size of the shaded angle.

2



6. Nadim bought a flat last year.
 The value of the flat has increased by 8% and it is now worth £94,500.
 Calculate how much Nadim paid for the flat.

3

7. Change the subject of the formula $P = \frac{1}{3}mn - r$ to m .

3

[Turn over



8. A wooden beam is used to support a wall built on horizontal ground as shown in the diagram.

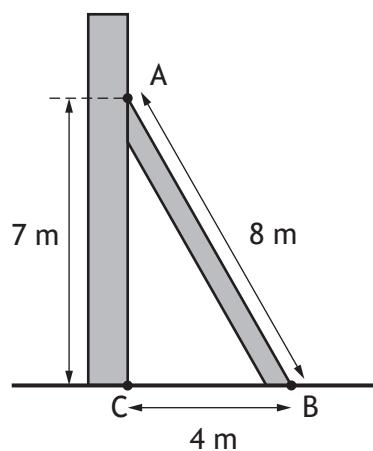

The edge of the beam, AB, is 8 metres long.

C is at the foot of the wall.

A is 7 metres from C.

B is 4 metres from C.

Determine whether the wall is perpendicular to the ground.

Justify your answer.

4



9. A concrete block is in the shape of a large pyramid with a small pyramid removed.

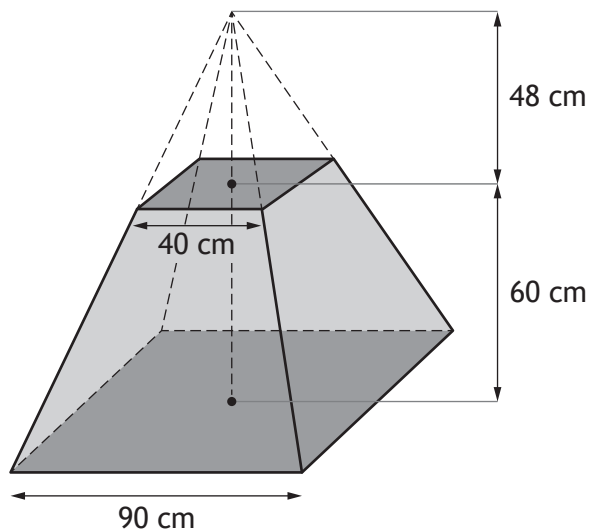

The large pyramid has a square base of length 90 centimetres.

The small pyramid has a square base of length 40 centimetres and a height of 48 centimetres.

The block has height 60 centimetres.

Calculate the volume of the block.

4

[Turn over



10. Express

$$\frac{7}{x-3} - \frac{2}{x}, \quad x \neq 3, x \neq 0$$

as a single fraction in its simplest form.

3



11. Anna has a grandfather clock in her house.

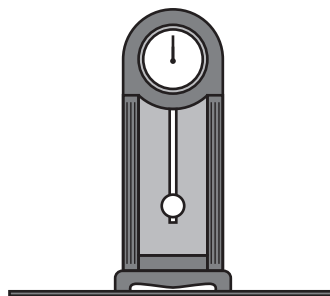

The height of the tip of the hour hand above the floor, in centimetres, is given by

$$h = 20 \cos x^\circ + 147$$

where x° is the angle the **hour hand** has rotated through since 12 o'clock.

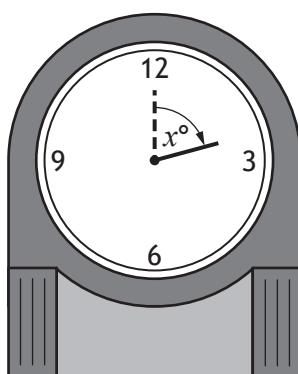

Calculate the first two values of x for which the tip of the hour hand is 150 centimetres above the floor.

4



* X 8 4 7 7 5 0 2 1 1 *

12. Simplify $\frac{x^2 - 16}{x^2 + x - 20}$.

3

13. Simplify $2 \sin^2 x^\circ + 2 \cos^2 x^\circ$.
Show your working.

2



* X 8 4 7 7 5 0 2 1 2 *

14. A storage unit, built in the shape of a cuboid, is shown.

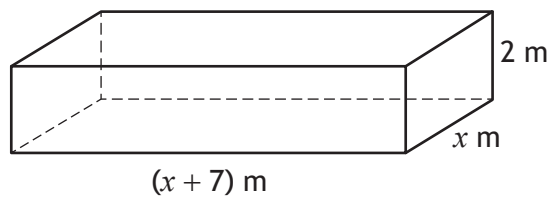

It has length $(x + 7)$ metres, breadth x metres and height 2 metres.
The volume of this unit is 45 cubic metres.

(a) Show that $2x^2 + 14x - 45 = 0$.

2

(b) Calculate x , the breadth of the storage unit.
Give your answer correct to 1 decimal place.

4

[Turn over



15. In the diagram:

- AC is perpendicular to BC
- AB = 18 centimetres
- BD = 6 centimetres
- BC = 8 centimetres.

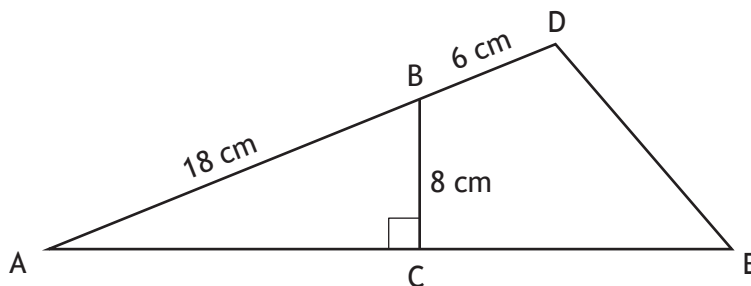

The area of triangle ADE is 160 square centimetres.

Calculate the length of AE.

4

[END OF QUESTION PAPER]



MARKS DO NOT
WRITE IN
THIS
MARGIN

ADDITIONAL SPACE FOR ANSWERS



* X 8 4 7 7 5 0 2 1 5 *

MARKS DO NOT
WRITE IN
THIS
MARGIN

ADDITIONAL SPACE FOR ANSWERS



* X 8 4 7 7 5 0 2 1 6 *