



National
Qualifications
2014

X757/75/02

**Physics
Section 1—Questions**

THURSDAY, 22 MAY

9:00 AM – 11:00 AM

Instructions for the completion of Section 1 are given on Page two of your question and answer booklet X757/75/01.

Record your answers on the answer grid on Page three of your question and answer booklet.

Reference may be made to the Data Sheet on Page two of this booklet and to the Relationship Sheet X757/75/11.

Before leaving the examination room you must give your question and answer booklet to the Invigilator; if you do not, you may lose all the marks for this paper.



DATA SHEET

Speed of light in materials

Material	Speed in m s^{-1}
Air	3.0×10^8
Carbon dioxide	3.0×10^8
Diamond	1.2×10^8
Glass	2.0×10^8
Glycerol	2.1×10^8
Water	2.3×10^8

Speed of sound in materials

Material	Speed in m s^{-1}
Aluminium	5200
Air	340
Bone	4100
Carbon dioxide	270
Glycerol	1900
Muscle	1600
Steel	5200
Tissue	1500
Water	1500

Gravitational field strengths

	Gravitational field strength on the surface in N kg^{-1}
Earth	9.8
Jupiter	23
Mars	3.7
Mercury	3.7
Moon	1.6
Neptune	11
Saturn	9.0
Sun	270
Uranus	8.7
Venus	8.9

Specific heat capacity of materials

Material	Specific heat capacity in $\text{J kg}^{-1} \text{ }^\circ\text{C}^{-1}$
Alcohol	2350
Aluminium	902
Copper	386
Glass	500
Ice	2100
Iron	480
Lead	128
Oil	2130
Water	4180

Specific latent heat of fusion of materials

Material	Specific latent heat of fusion in J kg^{-1}
Alcohol	0.99×10^5
Aluminium	3.95×10^5
Carbon Dioxide	1.80×10^5
Copper	2.05×10^5
Iron	2.67×10^5
Lead	0.25×10^5
Water	3.34×10^5

Melting and boiling points of materials

Material	Melting point in $^\circ\text{C}$	Boiling point in $^\circ\text{C}$
Alcohol	-98	65
Aluminium	660	2470
Copper	1077	2567
Glycerol	18	290
Lead	328	1737
Iron	1537	2737

Specific latent heat of vaporisation of materials

Material	Specific latent heat of vaporisation in J kg^{-1}
Alcohol	11.2×10^5
Carbon Dioxide	3.77×10^5
Glycerol	8.30×10^5
Turpentine	2.90×10^5
Water	22.6×10^5

Radiation weighting factors

Type of radiation	Radiation weighting factor
alpha	20
beta	1
fast neutrons	10
gamma	1
slow neutrons	3
X-rays	1

SECTION 1

1. The voltage of an electrical supply is a measure of the
- A resistance of the circuit
 - B speed of the charges in the circuit
 - C power developed in the circuit
 - D energy given to the charges in the circuit
 - E current in the circuit.
2. Four circuit symbols, W, X, Y and Z, are shown.

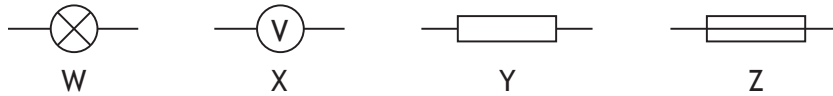

Which row identifies the components represented by these symbols?

	W	X	Y	Z
A	battery	ammeter	resistor	variable resistor
B	battery	ammeter	fuse	resistor
C	lamp	ammeter	variable resistor	resistor
D	lamp	voltmeter	resistor	fuse
E	lamp	voltmeter	variable resistor	fuse

[Turn over

3. A student suspects that ammeter A_1 may be inaccurate. Ammeter A_2 is known to be accurate.

Which of the following circuits should be used to compare the reading on A_1 with A_2 ?

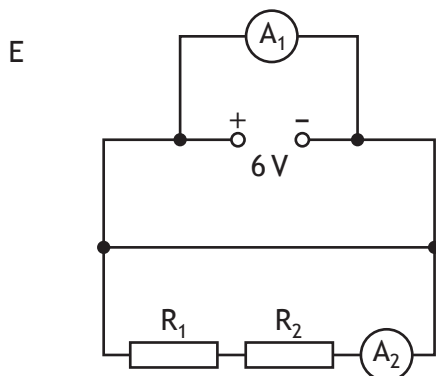
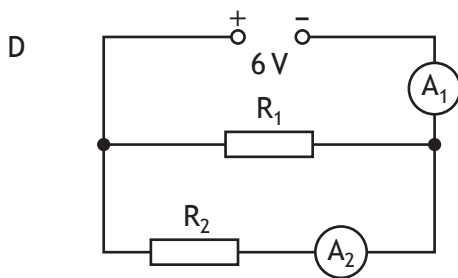
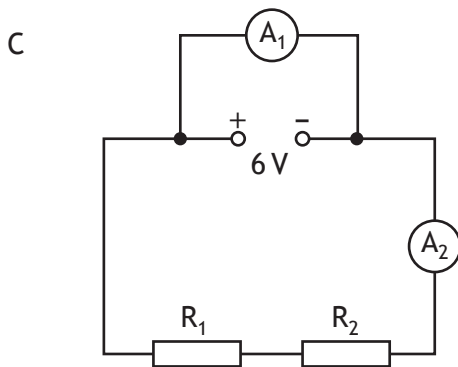
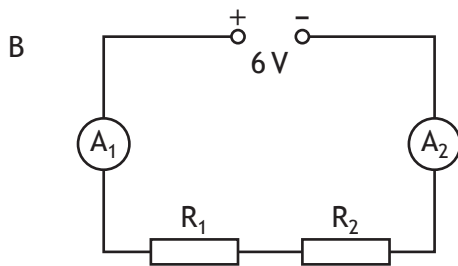
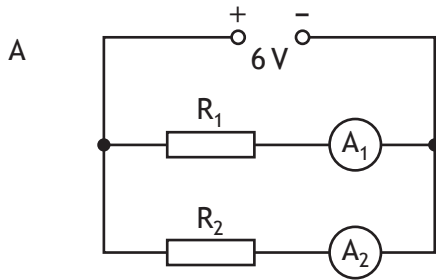

4. A ball of mass 0.50 kg is released from a height of 1.00 m and falls towards the floor.

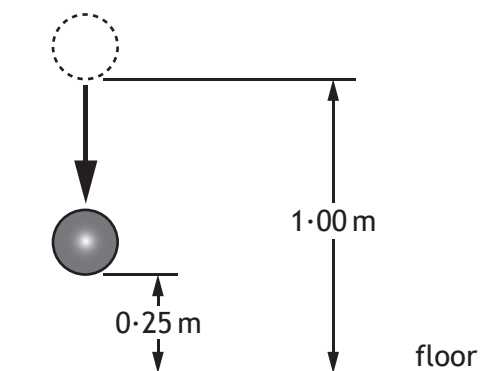

Which row in the table shows the gravitational potential energy and the kinetic energy of the ball when it is at a height of 0.25 m from the floor?

	<i>Gravitational potential energy</i> (J)	<i>Kinetic energy</i> (J)
A	0.12	0.12
B	1.2	1.2
C	1.2	3.7
D	3.7	1.2
E	4.9	1.2

5. The pressure of a fixed mass of gas is 6.0×10^5 Pa.
The temperature of the gas is 27°C and the volume of the gas is 2.5 m^3 .
The temperature of the gas increases to 54°C and the volume of the gas increases to 5.0 m^3 .

What is the new pressure of the gas?

- A 2.8×10^5 Pa
- B 3.3×10^5 Pa
- C 6.0×10^5 Pa
- D 1.1×10^6 Pa
- E 1.3×10^6 Pa

[Turn over

6. A student is investigating the relationship between the volume and the kelvin temperature of a fixed mass of gas at constant pressure.

Which graph shows this relationship?

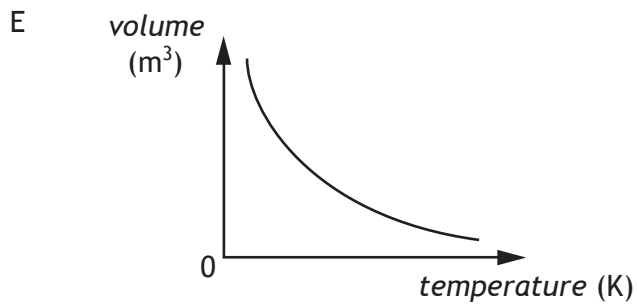
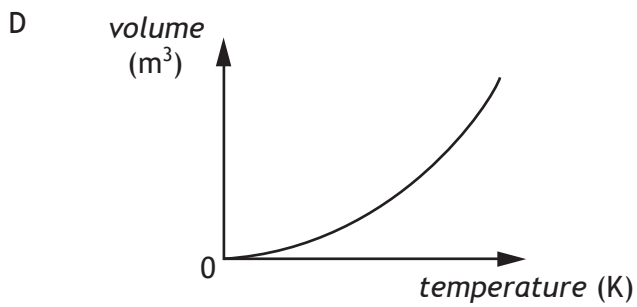
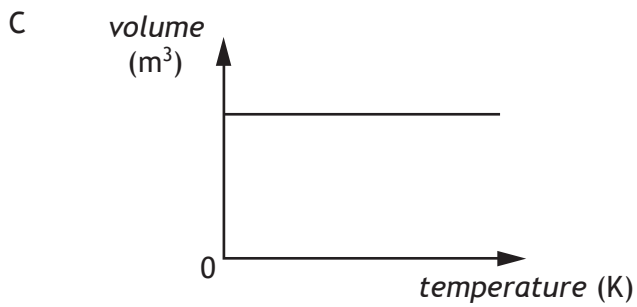
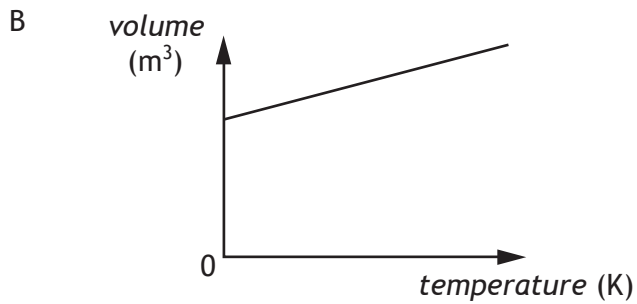
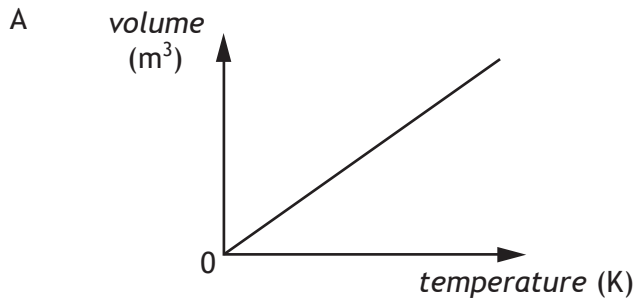

7. A liquid is heated from 17°C to 50°C. The temperature rise in kelvin is

- A 33 K
- B 67 K
- C 306 K
- D 340 K
- E 579 K.

8. The period of vibration of a guitar string is 8 ms.

The frequency of the sound produced by the guitar string is

- A 0.125 Hz
- B 12.5 Hz
- C 125 Hz
- D 800 Hz
- E 8000 Hz.

9. A student makes the following statements about microwaves and radio waves.

- I In air, microwaves travel faster than radio waves.
- II In air, microwaves have a longer wavelength than radio waves.
- III Microwaves and radio waves are both members of the electromagnetic spectrum.

Which of these statements is/are correct?

- A I only
- B III only
- C I and II only
- D I and III only
- E II and III only

10. Which row describes alpha (α), beta (β) and gamma (γ) radiations?

	α	β	γ
A	helium nucleus	electromagnetic radiation	electron from the nucleus
B	helium nucleus	electron from the nucleus	electromagnetic radiation
C	electron from the nucleus	helium nucleus	electromagnetic radiation
D	electromagnetic radiation	helium nucleus	electron from the nucleus
E	electromagnetic radiation	electron from the nucleus	helium nucleus

11. A sample of tissue is irradiated using a radioactive source.
A student makes the following statements about the sample.
- I The equivalent dose received by the sample is reduced by shielding the sample with a lead screen.
 - II The equivalent dose received by the sample is increased as the distance from the source to the sample is increased.
 - III The equivalent dose received by the sample is increased by increasing the time of exposure of the sample to the radiation.

Which of these statements is/are correct?

- A I only
 - B II only
 - C I and II only
 - D II and III only
 - E I and III only
12. The half-life of a radioactive source is 64 years.

In 2 hours, 1.44×10^8 radioactive nuclei in the source decay.

What is the activity of the source in Bq?

- A 2×10^4
 - B 4×10^4
 - C 1.2×10^6
 - D 2.25×10^6
 - E 7.2×10^7
13. A student makes the following statements about the fission process in a nuclear power station.
- I Electrons are used to bombard a uranium nucleus.
 - II Heat is produced.
 - III The neutrons released can cause other nuclei to undergo fission.

Which of these statements is/are correct?

- A I only
- B II only
- C III only
- D I and II only
- E II and III only

14. Which of the following contains two vectors and one scalar quantity?
- A Acceleration, mass, displacement
 - B Displacement, force, velocity
 - C Time, distance, force
 - D Displacement, velocity, acceleration
 - E Speed, velocity, distance

15. A vehicle follows a course from R to T as shown.

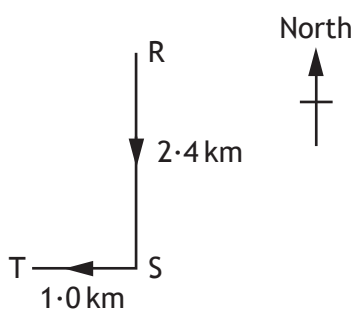

The total journey takes 1 hour.

Which row in the table gives the average speed and the average velocity of the vehicle for the whole journey?

	<i>Average speed</i>	<i>Average velocity</i>
A	2.6 km h ⁻¹ (023)	3.4 km h ⁻¹
B	2.6 km h ⁻¹	3.4 km h ⁻¹ (203)
C	3.4 km h ⁻¹ (203)	2.6 km h ⁻¹
D	3.4 km h ⁻¹	2.6 km h ⁻¹ (023)
E	3.4 km h ⁻¹	2.6 km h ⁻¹ (203)

16. A force of 10 N acts on an object for 2 s.
During this time the object moves a distance of 3 m.
The work done on the object is
- A 6.7 J
 - B 15 J
 - C 20 J
 - D 30 J
 - E 60 J.

17. Catapults are used by anglers to project fish bait into water.
A technician designs a catapult for this use.

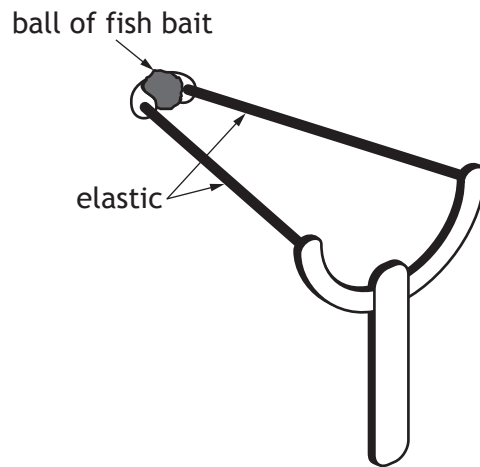

Pieces of elastic of different thickness are used to provide a force on the ball.

Each piece of elastic is the same length.

The amount of stretch given to each elastic is the same each time.

The force exerted on the ball increases as the thickness of the elastic increases.

Which row in the table shows the combination of the thickness of elastic and mass of ball that produces the greatest acceleration?

	<i>Thickness of elastic</i> (mm)	<i>Mass of ball</i> (kg)
A	5	0.01
B	10	0.01
C	10	0.02
D	15	0.01
E	15	0.02

18. A spacecraft completes the last stage of its journey back to Earth by parachute, falling with constant speed into the sea.

The spacecraft falls with constant speed because

- A the gravitational field strength of the Earth is constant near the Earth's surface
- B it has come from space where the gravitational field strength is almost zero
- C the air resistance is greater than the weight of the spacecraft
- D the weight of the spacecraft is greater than the air resistance
- E the air resistance is equal to the weight of the spacecraft.

19. A ball is released from point Q on a curved rail, leaves the rail horizontally at R and lands 1 s later.

The ball is now released from point P.

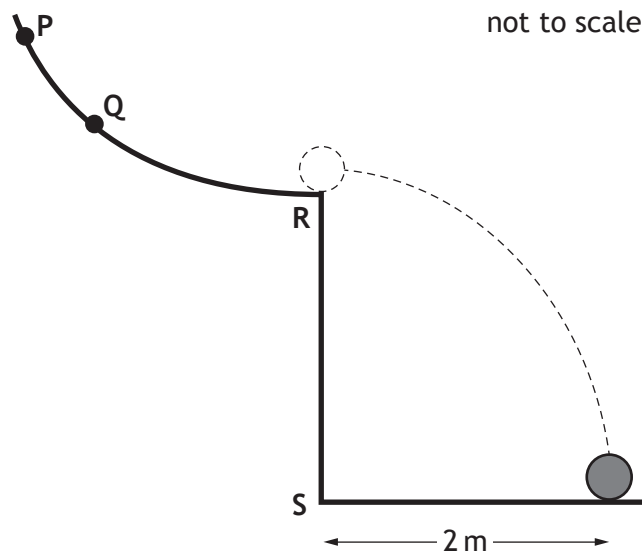

Which row describes the motion of the ball after leaving the rail?

	<i>Time to land after leaving rail</i>	<i>Distance from S to landing point</i>
A	1 s	less than 2 m
B	less than 1 s	more than 2 m
C	1 s	more than 2 m
D	less than 1 s	2 m
E	more than 1 s	more than 2 m

20. A solid substance is placed in an insulated flask and heated continuously with an immersion heater.

The graph shows how the temperature of the substance in the flask changes in time.

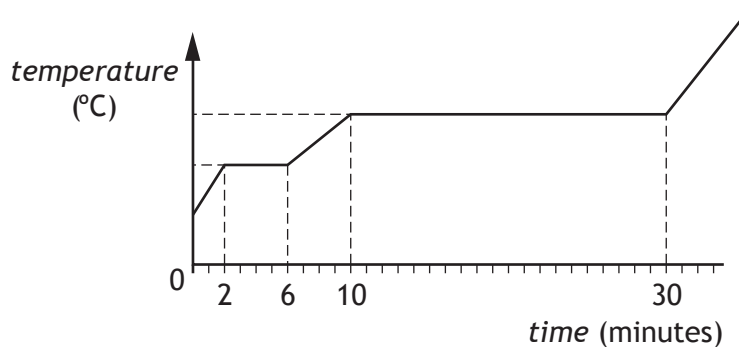

After 5 minutes the substance is a

- A solid
- B liquid
- C gas
- D mixture of solid and liquid
- E mixture of liquid and gas.

[END OF SECTION 1. NOW ATTEMPT THE QUESTIONS IN SECTION 2
OF YOUR QUESTION AND ANSWER BOOKLET]



FOR OFFICIAL USE

--	--	--	--	--	--

National
Qualifications
2014

Mark

--

X757/75/01

**Physics
Section 1—Answer Grid
and Section 2**

THURSDAY, 22 MAY

9:00 AM – 11:00 AM



* X 7 5 7 7 5 0 1 *

Fill in these boxes and read what is printed below.

Full name of centre

--

Town

--

Forename(s)

--

Surname

--

Number of seat

--

Date of birth

Day

Month

Year

D	D
---	---

M	M
---	---

Y	Y
---	---

Scottish candidate number

--	--	--	--	--	--	--	--	--	--

Total marks — 110

SECTION 1 — 20 marks

Attempt ALL questions in this section.

Instructions for the completion of Section 1 are given on Page two.

SECTION 2 — 90 marks

Attempt ALL questions in this section.

Write your answers clearly in the spaces provided in this booklet. Additional space for answers and rough work is provided at the end of this booklet. If you use this space you must clearly identify the question number you are attempting. Any rough work must be written in this booklet. You should score through your rough work when you have written your final copy.

Use **blue** or **black** ink.

Reference may be made to the Data Sheet on Page two of the question paper X757/75/02 and to the Relationship Sheet X757/75/11.

Care should be taken to give an appropriate number of significant figures in the final answers to calculations.

Before leaving the examination room you must give this booklet to the Invigilator; if you do not, you may lose all the marks for this paper.



The questions for Section 1 are contained in the question paper X757/75/02.
Read these and record your answers on the answer grid on Page three opposite.
Do NOT use gel pens.

1. The answer to each question is **either** A, B, C, D or E. Decide what your answer is, then fill in the appropriate bubble (see sample question below).
2. There is **only one correct** answer to each question.
3. Any rough work must be written in the additional space for answers and rough work at the end of this booklet.

Sample Question

The energy unit measured by the electricity meter in your home is the:

- A ampere
- B kilowatt-hour
- C watt
- D coulomb
- E volt.

The correct answer is **B**—kilowatt-hour. The answer **B** bubble has been clearly filled in (see below).

A	B	C	D	E
<input type="radio"/>	<input checked="" type="radio"/>	<input type="radio"/>	<input type="radio"/>	<input type="radio"/>

Changing an answer

If you decide to change your answer, cancel your first answer by putting a cross through it (see below) and fill in the answer you want. The answer below has been changed to **D**.

A	B	C	D	E
<input type="radio"/>	<input checked="" type="radio"/>	<input type="radio"/>	<input checked="" type="radio"/>	<input type="radio"/>

If you then decide to change back to an answer you have already scored out, put a tick (✓) to the **right** of the answer you want, as shown below:

A	B	C	D	E	or	A	B	C	D	E
<input type="radio"/>	<input checked="" type="radio"/>	<input type="radio"/>	<input checked="" type="radio"/>	<input type="radio"/>		<input type="radio"/>	<input checked="" type="radio"/>	<input type="radio"/>	<input type="radio"/>	<input type="radio"/>



SECTION 1 — Answer Grid



	A	B	C	D	E
1	<input type="radio"/>	<input type="radio"/>	<input type="radio"/>	<input type="radio"/>	<input type="radio"/>
2	<input type="radio"/>	<input type="radio"/>	<input type="radio"/>	<input type="radio"/>	<input type="radio"/>
3	<input type="radio"/>	<input type="radio"/>	<input type="radio"/>	<input type="radio"/>	<input type="radio"/>
4	<input type="radio"/>	<input type="radio"/>	<input type="radio"/>	<input type="radio"/>	<input type="radio"/>
5	<input type="radio"/>	<input type="radio"/>	<input type="radio"/>	<input type="radio"/>	<input type="radio"/>
6	<input type="radio"/>	<input type="radio"/>	<input type="radio"/>	<input type="radio"/>	<input type="radio"/>
7	<input type="radio"/>	<input type="radio"/>	<input type="radio"/>	<input type="radio"/>	<input type="radio"/>
8	<input type="radio"/>	<input type="radio"/>	<input type="radio"/>	<input type="radio"/>	<input type="radio"/>
9	<input type="radio"/>	<input type="radio"/>	<input type="radio"/>	<input type="radio"/>	<input type="radio"/>
10	<input type="radio"/>	<input type="radio"/>	<input type="radio"/>	<input type="radio"/>	<input type="radio"/>
11	<input type="radio"/>	<input type="radio"/>	<input type="radio"/>	<input type="radio"/>	<input type="radio"/>
12	<input type="radio"/>	<input type="radio"/>	<input type="radio"/>	<input type="radio"/>	<input type="radio"/>
13	<input type="radio"/>	<input type="radio"/>	<input type="radio"/>	<input type="radio"/>	<input type="radio"/>
14	<input type="radio"/>	<input type="radio"/>	<input type="radio"/>	<input type="radio"/>	<input type="radio"/>
15	<input type="radio"/>	<input type="radio"/>	<input type="radio"/>	<input type="radio"/>	<input type="radio"/>
16	<input type="radio"/>	<input type="radio"/>	<input type="radio"/>	<input type="radio"/>	<input type="radio"/>
17	<input type="radio"/>	<input type="radio"/>	<input type="radio"/>	<input type="radio"/>	<input type="radio"/>
18	<input type="radio"/>	<input type="radio"/>	<input type="radio"/>	<input type="radio"/>	<input type="radio"/>
19	<input type="radio"/>	<input type="radio"/>	<input type="radio"/>	<input type="radio"/>	<input type="radio"/>
20	<input type="radio"/>	<input type="radio"/>	<input type="radio"/>	<input type="radio"/>	<input type="radio"/>



[BLANK PAGE]

DO NOT WRITE ON THIS PAGE



* X 7 5 7 7 5 0 1 0 4 *

[Turn over for Question 1 on *Page six*

DO NOT WRITE ON THIS PAGE



SECTION 2 — 90 marks

Attempt ALL questions

MARKS

DO NOT
WRITE IN
THIS
MARGIN

1. A toy car contains an electric circuit which consists of a 12.0V battery, an electric motor and two lamps.



The circuit diagram is shown.

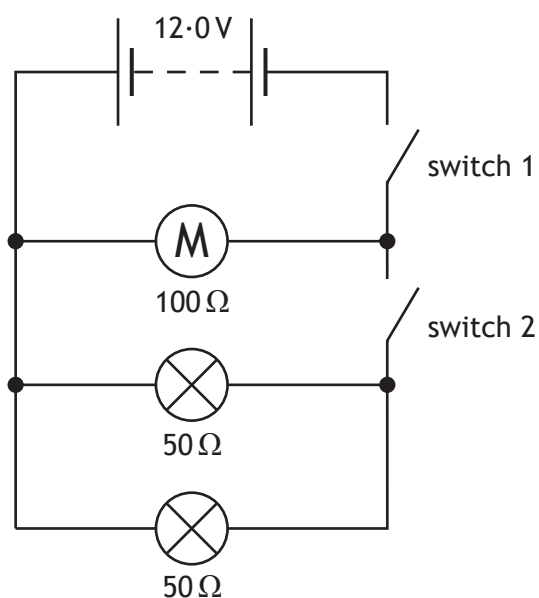

- (a) Switch 1 is now closed.

Calculate the power dissipated in the motor when operating.

3

Space for working and answer



MARKS DO NOT WRITE IN THIS MARGIN

1. (continued)

(b) Switch 2 is now also closed.

(i) Calculate the total resistance of the motor and the two lamps. 3

Space for working and answer

(ii) One of the lamps now develops a fault and stops working.

State the effect this has on the other lamp.

You **must** justify your answer. 2

Total marks 8

[Turn over



2. A thermistor is used as a temperature sensor in a circuit to monitor and control the temperature of water in a tank. Part of the circuit is shown.

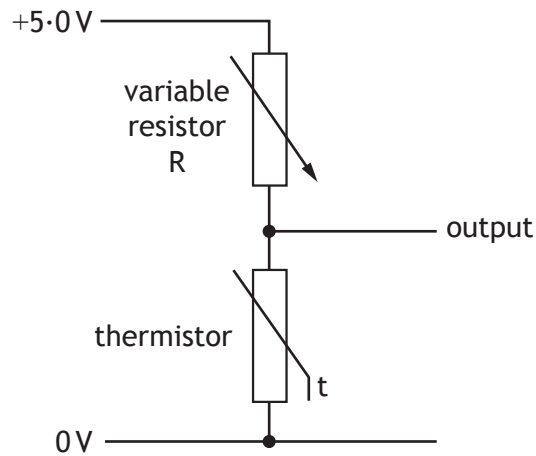

- (a) (i) The variable resistor R is set at a resistance of $1050\ \Omega$.

Calculate the resistance of the thermistor when the voltage across the thermistor is 2.0V .

4

Space for working and answer



* X 7 5 7 7 5 0 1 0 8 *

2. (a) (continued)

(ii) The graph shows how the resistance of the thermistor varies with temperature.

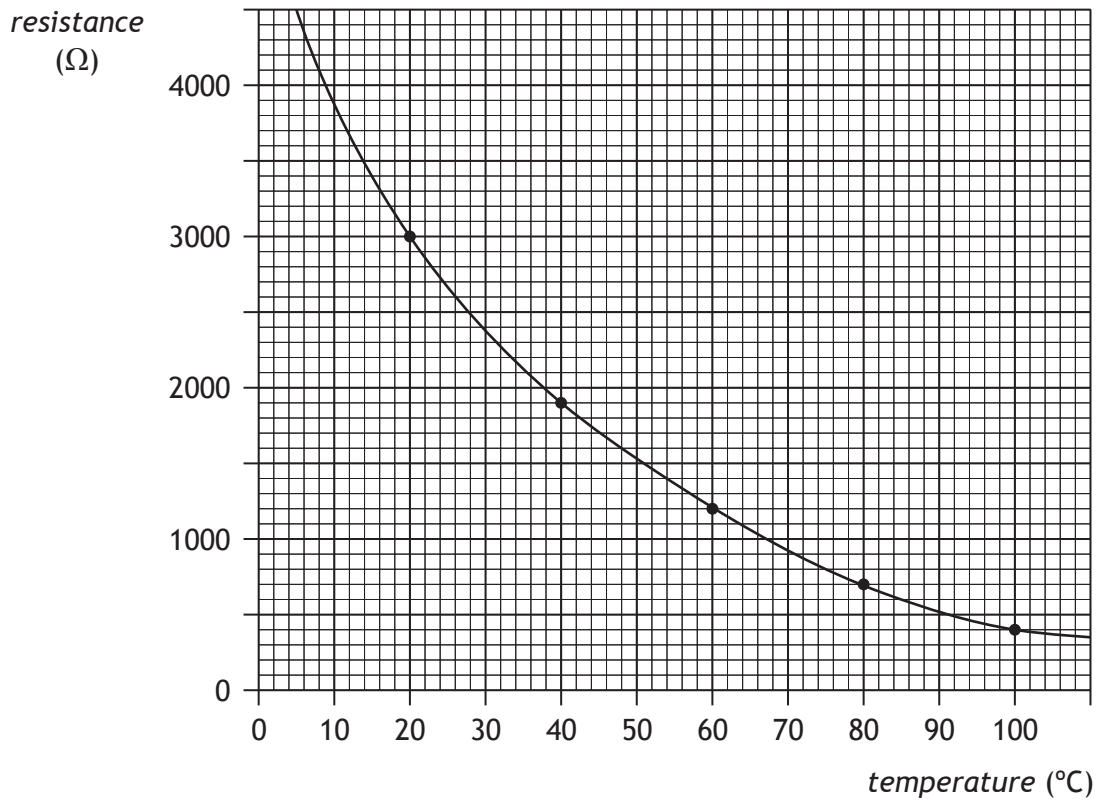

Use the graph to determine the temperature of the water when the voltage across the thermistor is 2.0 V.

1



2. (continued)

(b) The circuit is now connected to a switching circuit to operate a heater.

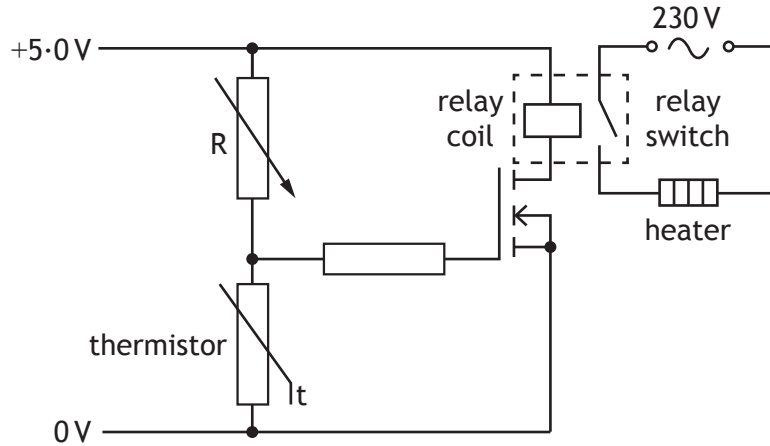

(i) Explain how the circuit operates to switch on the heater when the temperature falls below a certain value. 3

(ii) The resistance of the variable resistor R is now increased.
 What effect does this have on the temperature at which the heater is switched on?
 You **must** justify your answer. 3

Total marks 11



[Turn over for Question 3 on *Page twelve*

DO NOT WRITE ON THIS PAGE



3. A student is investigating the specific heat capacity of three metal blocks X, Y and Z.

Each block has a mass of 1.0 kg.

A heater and thermometer are inserted into a block as shown.

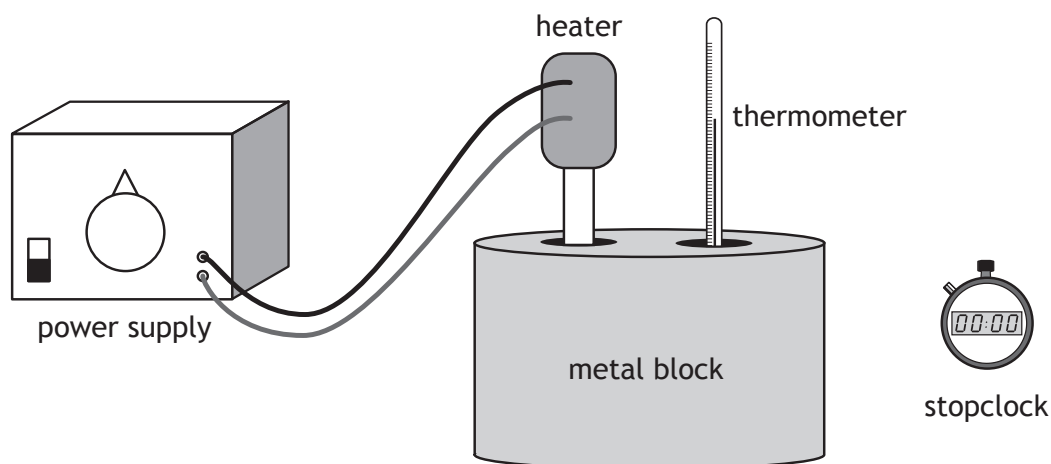

The heater has a power rating of 15 W.

The initial temperature of the block is measured.

The heater is switched on for 10 minutes and the final temperature of the block is recorded.

This procedure is repeated for the other two blocks.

The student's results are shown in the table.

Block	Initial temperature (°C)	Final temperature (°C)
X	15	25
Y	15	85
Z	15	34

- (a) Show that the energy provided by the heater to each block is 9000 J.

2

Space for working and answer



MARKS

DO NOT
WRITE IN
THIS
MARGIN

3. (continued)

(b) (i) By referring to the results in the table, identify the block that has the greatest specific heat capacity. 1

(ii) Calculate the specific heat capacity of the block identified in (b)(i). 3
Space for working and answer

(c) Due to energy losses, the specific heat capacities calculated in this investigation are different from the accepted values.

The student decides to improve the set up in order to obtain a value closer to the accepted value for each block.

(i) Suggest a possible improvement that would reduce energy losses. 1

(ii) State the effect that this improvement would have on the final temperature. 1

Total marks 8



MARKS

DO NOT
WRITE IN
THIS
MARGIN

4. A student, fishing from a pier, counts four waves passing the end of the pier in 20 seconds. The student estimates that the wavelength of the waves is 12 m.

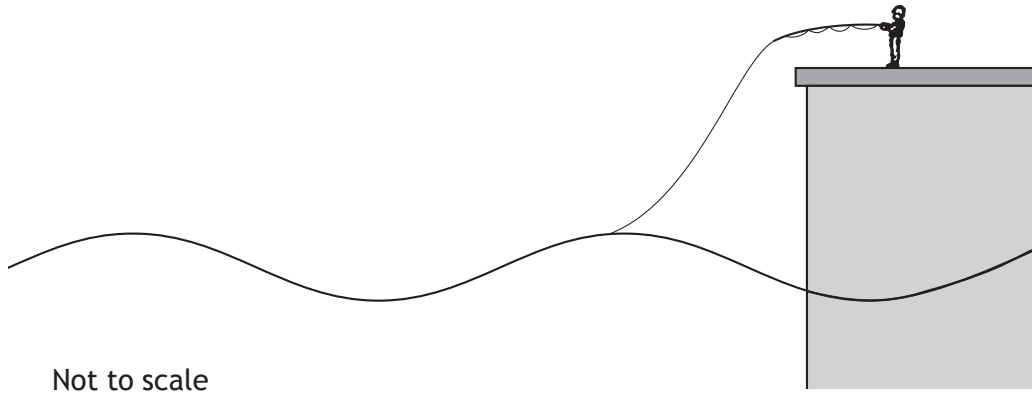

Not to scale

- (a) Calculate the speed of the water waves.
Space for working and answer

4



4. (continued)

- (b) When looking down into the calm water behind the pier the student sees a fish.

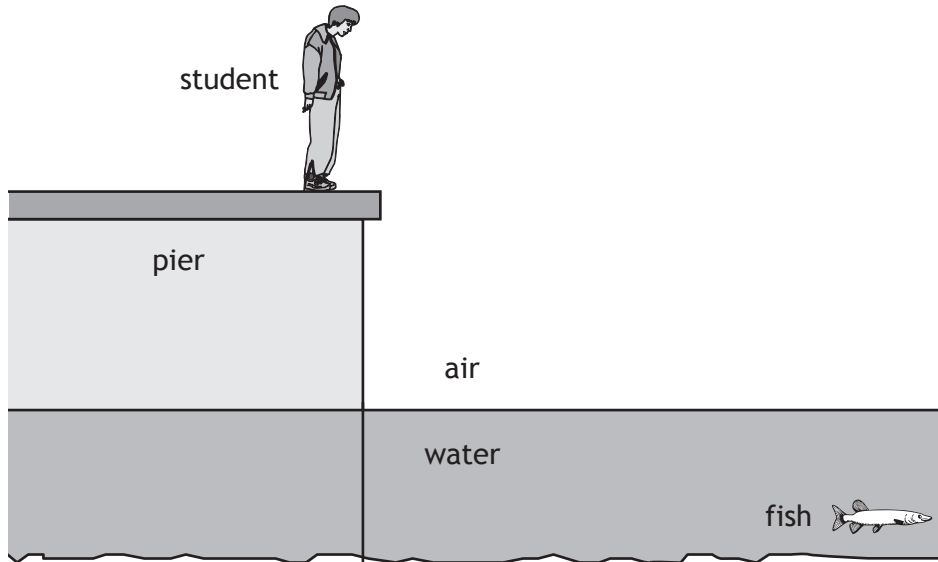

Complete the diagram to show the path of a ray of light from the fish to the student.

You should include the normal in your diagram.

3

(An additional diagram, if required, can be found on *Page thirty-one.*)

Total marks 7

[Turn over



5. The UV Index is an international standard measurement of the intensity of ultraviolet radiation from the Sun. Its purpose is to help people to effectively protect themselves from UV rays.

The UV index table is shown.

<i>UV Index</i>	<i>Description</i>
0 – 2	Low risk from the Sun's UV rays for the average person
3 – 5	Moderate risk of harm from unprotected Sun exposure
6 – 7	High risk of harm from unprotected Sun exposure
8 – 10	Very high risk of harm from unprotected Sun exposure
11+	Extreme risk of harm from unprotected Sun exposure

The UV index can be calculated using

$$UV\ index = \left[\frac{\text{total effect of UV radiation}}{\text{elevation above sea level adjustment}} \times \frac{\text{cloud adjustment}}{25} \right]$$

The UV index is then rounded to the nearest whole number.

The tables below give information for elevation above sea level and cloud cover.

<i>Elevation above sea level (km)</i>	<i>Elevation above sea level adjustment</i>
1	1.06
2	1.12
3	1.18

<i>Cloud cover</i>	<i>Cloud adjustment</i>
Clear skies	1.00
Scattered clouds	0.89
Broken clouds	0.73
Overcast skies	0.31



* X 7 5 7 7 5 0 1 1 6 *

5. (continued)

MARKS

DO NOT
WRITE IN
THIS
MARGIN

- (a) At a particular location the total effect of UV radiation is 280.
The elevation is 2 km above sea level with overcast skies.
Calculate the UV index value for this location.

2

Space for working and answer

- (b) Applying sunscreen to the skin is one method of protecting people from the Sun's harmful UV rays. UV radiation can be divided into three wavelength ranges, called UVA, UVB and UVC.

A manufacturer carries out some tests on experimental sunscreens P, Q and R to determine how effective they are at absorbing UV radiation. The test results are displayed in the graph.

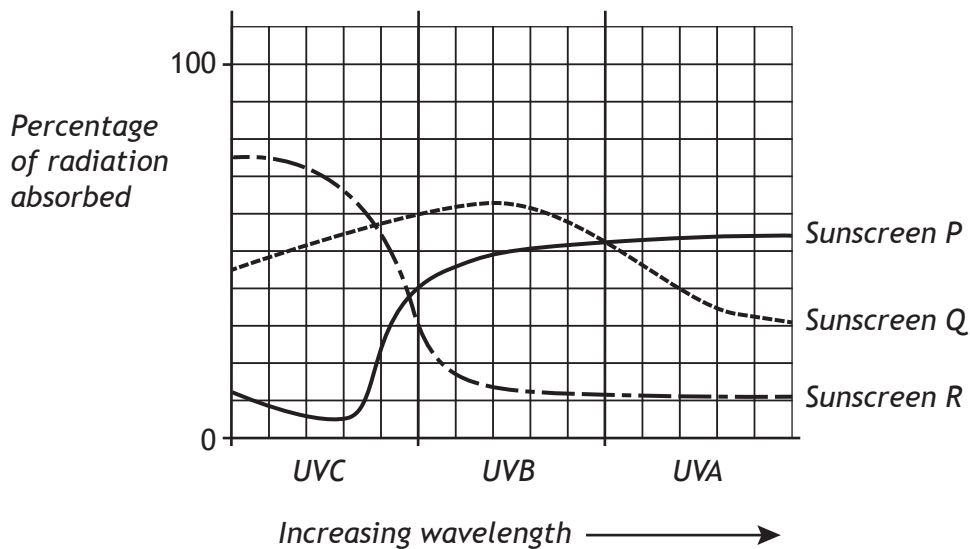

Using information from the graph, complete the following table.

2

	UVA	UVB	UVC
Type of sunscreen that absorbs most of this radiation		Sunscreen Q	
Type of sunscreen that absorbs least of this radiation	Sunscreen R		

- (c) State one useful application of UV radiation.

1

Total marks 5



6. A technician carries out an experiment, using the apparatus shown, to determine the half-life of a radioactive source.

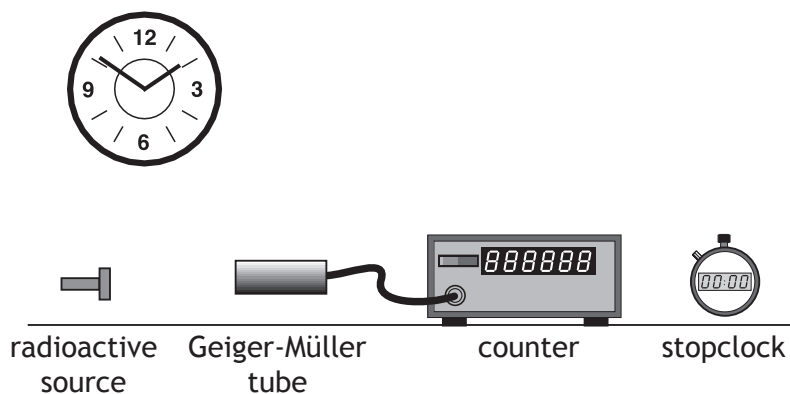

- (a) State what is meant by the term *half-life*.

1

- (b) The technician displays the data obtained from the experiment in the graph below.

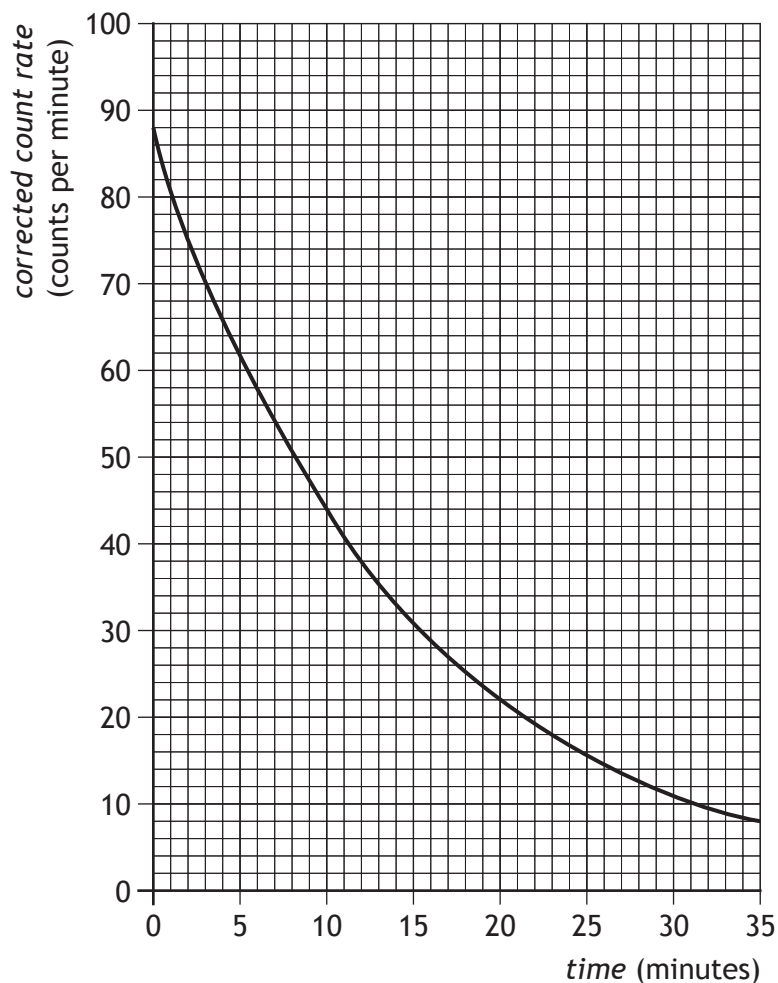

MARKS

DO NOT
WRITE IN
THIS
MARGIN

6. (b) (continued)

(i) Describe how the apparatus could be used to obtain the experimental data required to produce this graph.

3

(ii) Use information from the graph to determine the half-life of the radioactive source.

1

(iii) Determine the corrected count rate after 40 minutes.

2

Space for working and answer

Total marks 7



* X 7 5 7 7 5 0 1 1 9 *

7. A fire engine on its way to an emergency is travelling along a main street. The siren on the fire engine is sounding.

A student standing in a nearby street cannot see the fire engine but can hear the siren.

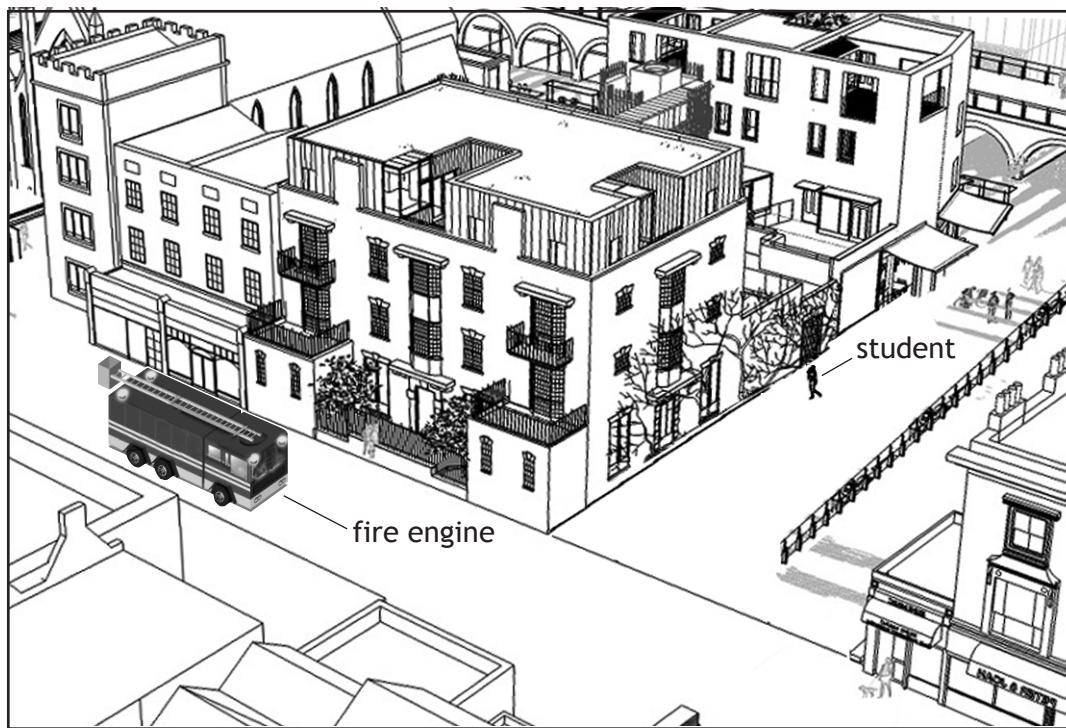

Use your knowledge of physics to comment on why the student can hear the siren even though the fire engine is not in view.

3



* X 7 5 7 7 5 0 1 2 0 *

8. An airport worker passes suitcases through an X-ray machine.



(a) The worker has a mass of 80.0 kg and on a particular day absorbs 7.2 mJ of energy from the X-ray machine.

(i) Calculate the absorbed dose received by the worker.

3

Space for working and answer

(ii) Calculate the equivalent dose received by the worker.

3

Space for working and answer





8. (continued)

(b) X-rays can cause ionisation.

Explain what is meant by *ionisation*.

MARKS

DO NOT
WRITE IN
THIS
MARGIN

1

Total marks 7



* X 7 5 7 7 5 0 1 2 2 *

MARKS

DO NOT
WRITE IN
THIS
MARGIN

9. A communications satellite is used to transmit live television broadcasts from the UK to Canada.

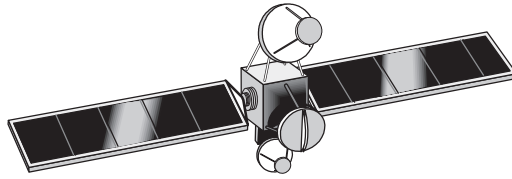

A student states that, to allow the live television broadcasts to be received in Canada, it is important that the satellite does not move.

Use your knowledge of physics to comment on this statement.

3

[Turn over



10. In a rowing event a boat moves off in a straight line.



A graph of the boat's motion is shown.

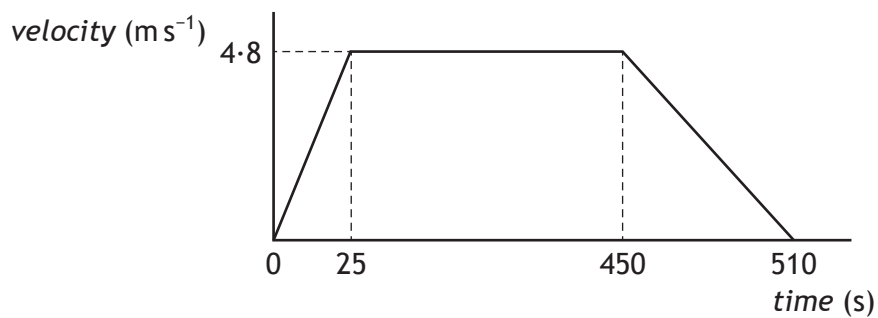

(a) (i) Calculate the acceleration of the boat during the first 25 s. 3
Space for working and answer

(ii) Describe the motion of the boat between 25 s and 450 s. 1



MARKS

DO NOT
WRITE IN
THIS
MARGIN

10. (a) (continued)

(iii) Draw a diagram showing the horizontal forces acting on the boat between 25 s and 450 s.

You **must** name these forces and show their directions.

2

(b) The boat comes to rest after 510 s.

(i) Calculate the total distance travelled by the boat.

3

Space for working and answer

(ii) Calculate the average velocity of the boat.

A direction is not required.

3

Space for working and answer

Total marks 12



* X 7 5 7 7 5 0 1 2 5 *

11. A helicopter is used to take tourists on sightseeing flights. Information about the helicopter is shown in the table.



weight of empty helicopter	13 500 N
maximum take-off weight	24 000 N
cruising speed	67 m s ⁻¹
maximum speed	80 m s ⁻¹
maximum range	610 km

- (a) The pilot and passengers are weighed before they board the helicopter. Explain the reason for this.

1

- (b) Six passengers and the pilot with a combined weight of 6125 N board the helicopter.

Determine the minimum upward force required by the helicopter at take-off.

1

Space for working and answer



12. A student is investigating the motion of water rockets. The water rocket is made from an upturned plastic bottle containing some water. Air is pumped into the bottle. When the pressure of the air is great enough the plastic bottle is launched upwards.

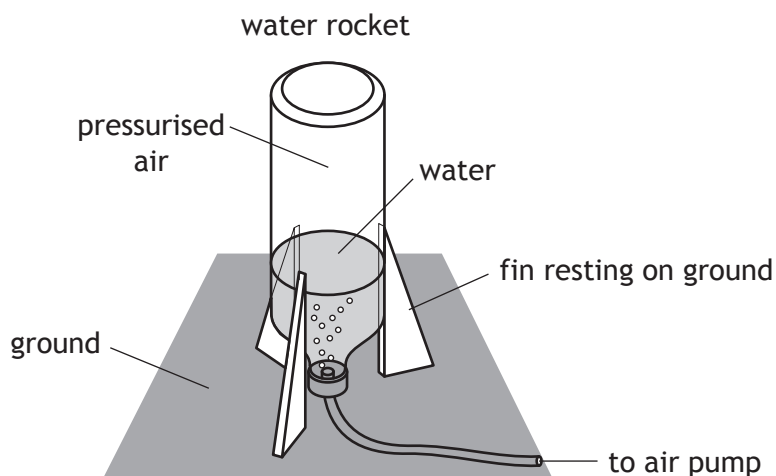

The mass of the rocket before launch is 0.94 kg.

- (a) Calculate the weight of the water rocket.

3

Space for working and answer

- (b) Before launch, the water rocket rests on three fins on the ground.

The area of each fin in contact with the ground is $2.0 \times 10^{-4} \text{ m}^2$.

Calculate the total pressure exerted on the ground by the fins.

4

Space for working and answer





12. (continued)

MARKS
DO NOT
WRITE IN
THIS
MARGIN

(c) Use Newton's Third Law to explain how the rocket launches.

1

(d) At launch, the initial upward thrust on the rocket is 370 N.
Calculate the initial acceleration of the rocket.

4

Space for working and answer

(e) The student launches the rocket a second time.

For this launch, the student adds a greater volume of water than before.

The same initial upward thrust acts on the rocket but it fails to reach the same height.

Explain why the rocket fails to reach the same height.

2

Total marks 14

[END OF QUESTION PAPER]



* X 7 5 7 7 5 0 1 2 9 *



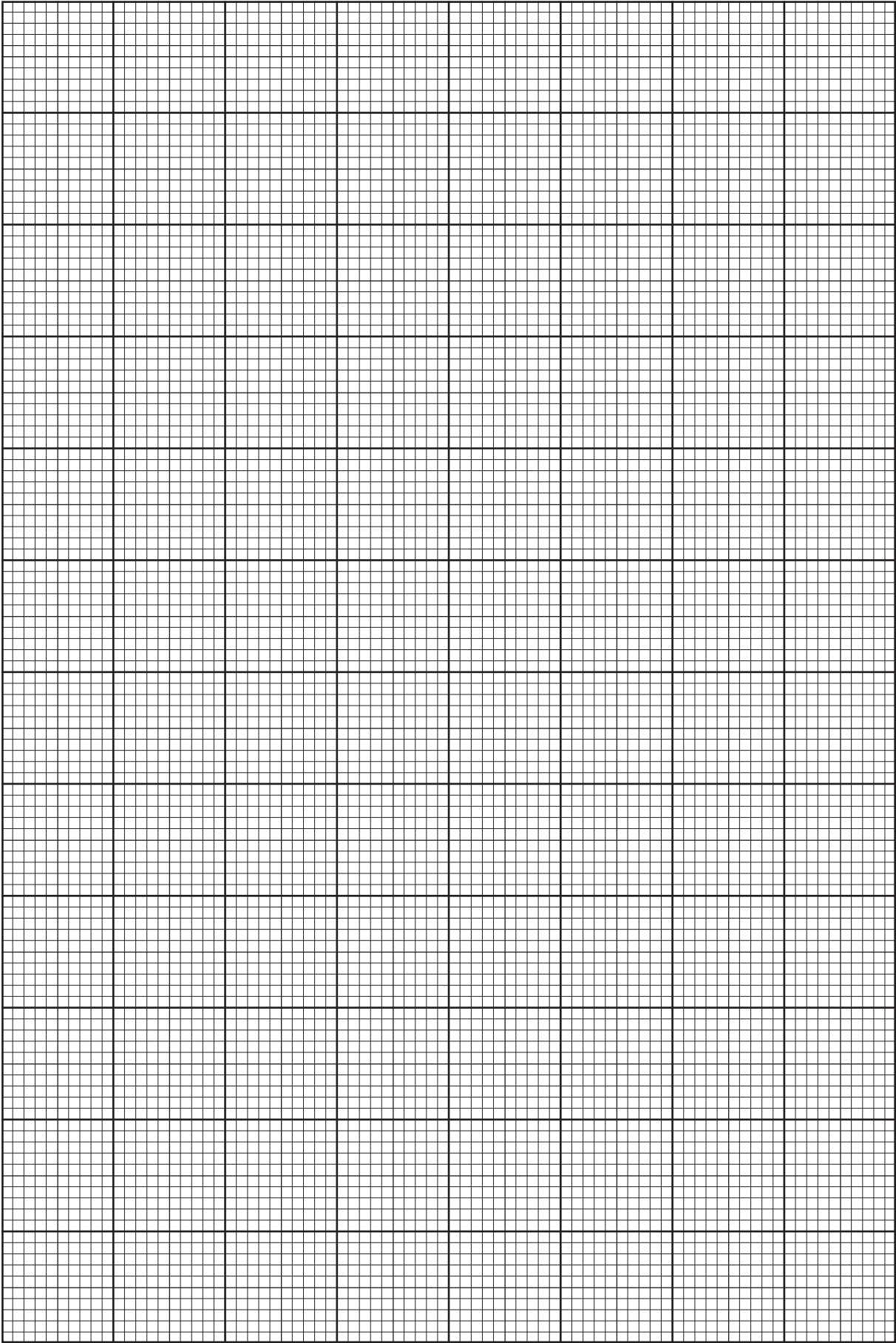

ADDITIONAL SPACE FOR ANSWERS AND ROUGH WORK

MARKS
DO NOT
WRITE IN
THIS
MARGIN

Additional diagram for Question 4 (b)

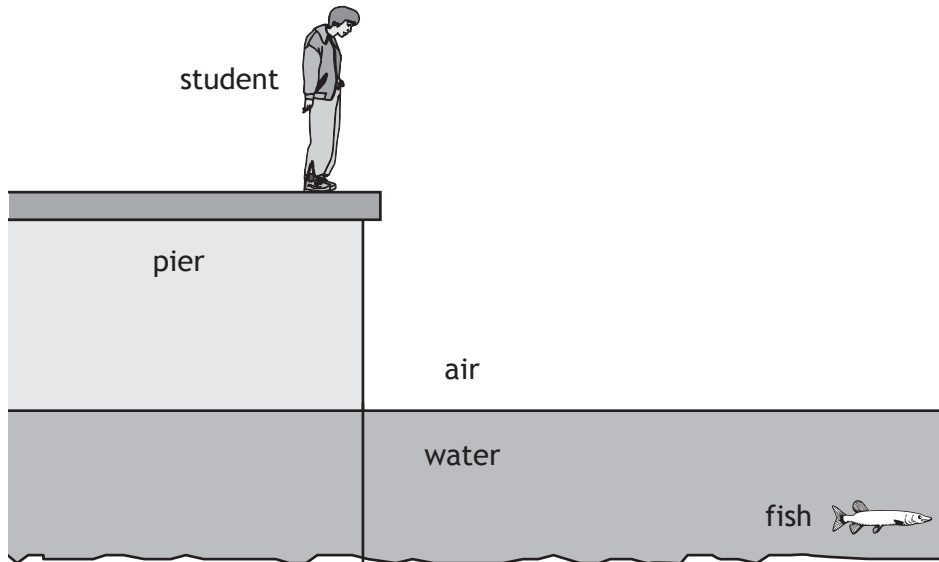

ADDITIONAL SPACE FOR ANSWERS AND ROUGH WORK

MARKS

DO NOT
WRITE IN
THIS
MARGIN



* X 7 5 7 7 5 0 1 3 2 *

ADDITIONAL SPACE FOR ANSWERS AND ROUGH WORK

MARKS

DO NOT
WRITE IN
THIS
MARGIN



* X 7 5 7 7 5 0 1 3 3 *

[BLANK PAGE]

DO NOT WRITE ON THIS PAGE



[BLANK PAGE]

DO NOT WRITE ON THIS PAGE





ACKNOWLEDGEMENTS

Question 1—32618 Stuart Elflett/Shutterstock.com

Question 8—86789524 Ints Vikmanis/Shutterstock.com

Question 10—804267 Sandra R. Barba/Shutterstock.com