



National
Qualifications
2015

X757/75/02

**Physics
Section 1—Questions**

TUESDAY, 5 MAY
9:00 AM – 11:00 AM

Instructions for the completion of Section 1 are given on *Page two* of your question and answer booklet X757/75/01.

Record your answers on the answer grid on *Page three* of your question and answer booklet.

Reference may be made to the Data Sheet on *Page two* of this booklet and to the Relationship Sheet X757/75/11.

Before leaving the examination room you must give your question and answer booklet to the Invigilator; if you do not, you may lose all the marks for this paper.



* X 7 5 7 7 5 0 2 *

DATA SHEET

Speed of light in materials

Material	Speed in m s^{-1}
Air	3.0×10^8
Carbon dioxide	3.0×10^8
Diamond	1.2×10^8
Glass	2.0×10^8
Glycerol	2.1×10^8
Water	2.3×10^8

Speed of sound in materials

Material	Speed in m s^{-1}
Aluminium	5200
Air	340
Bone	4100
Carbon dioxide	270
Glycerol	1900
Muscle	1600
Steel	5200
Tissue	1500
Water	1500

Gravitational field strengths

	Gravitational field strength on the surface in N kg^{-1}
Earth	9.8
Jupiter	23
Mars	3.7
Mercury	3.7
Moon	1.6
Neptune	11
Saturn	9.0
Sun	270
Uranus	8.7
Venus	8.9

Specific heat capacity of materials

Material	Specific heat capacity in $\text{J kg}^{-1} \text{ } ^\circ\text{C}^{-1}$
Alcohol	2350
Aluminium	902
Copper	386
Glass	500
Ice	2100
Iron	480
Lead	128
Oil	2130
Water	4180

Specific latent heat of fusion of materials

Material	Specific latent heat of fusion in J kg^{-1}
Alcohol	0.99×10^5
Aluminium	3.95×10^5
Carbon Dioxide	1.80×10^5
Copper	2.05×10^5
Iron	2.67×10^5
Lead	0.25×10^5
Water	3.34×10^5

Melting and boiling points of materials

Material	Melting point in $^\circ\text{C}$	Boiling point in $^\circ\text{C}$
Alcohol	-98	65
Aluminium	660	2470
Copper	1077	2567
Glycerol	18	290
Lead	328	1737
Iron	1537	2737

Specific latent heat of vaporisation of materials

Material	Specific latent heat of vaporisation in J kg^{-1}
Alcohol	11.2×10^5
Carbon Dioxide	3.77×10^5
Glycerol	8.30×10^5
Turpentine	2.90×10^5
Water	22.6×10^5

Radiation weighting factors

Type of radiation	Radiation weighting factor
alpha	20
beta	1
fast neutrons	10
gamma	1
slow neutrons	3
X-rays	1

SECTION 1
Attempt ALL questions

1. Two circuits are set up as shown.

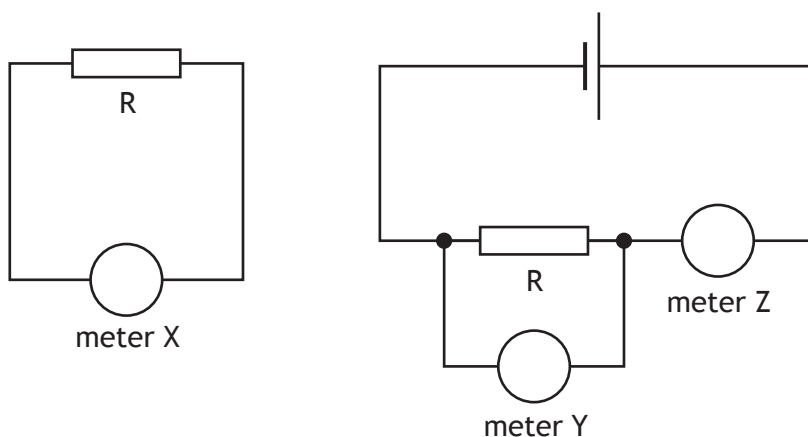

Both circuits are used to determine the resistance of resistor R.
Which row in the table identifies meter X, meter Y and meter Z?

	<i>meter X</i>	<i>meter Y</i>	<i>meter Z</i>
A	ohmmeter	voltmeter	ammeter
B	ohmmeter	ammeter	voltmeter
C	voltmeter	ammeter	ohmmeter
D	ammeter	voltmeter	ohmmeter
E	voltmeter	ohmmeter	ammeter

2. Which of the following statements is/are correct?

- I The voltage of a battery is the number of joules of energy it gives to each coulomb of charge.
 - II A battery only has a voltage when it is connected in a complete circuit.
 - III Electrons are free to move within an insulator.
- A I only
 B II only
 C III only
 D II and III only
 E I, II and III

[Turn over

3. A circuit is set up as shown.

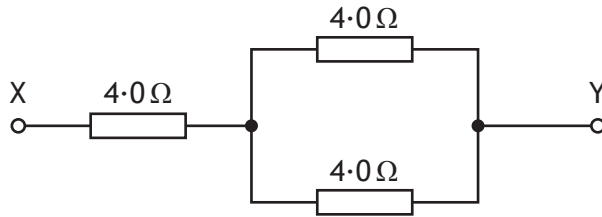

The resistance between X and Y is

- A $1.3\ \Omega$
 - B $4.5\ \Omega$
 - C $6.0\ \Omega$
 - D $8.0\ \Omega$
 - E $12\ \Omega$.
4. The rating plate on an electrical appliance is shown.

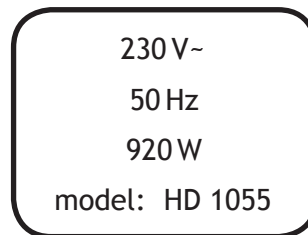

The resistance of this appliance is

- A $0.017\ \Omega$
- B $0.25\ \Omega$
- C $4.0\ \Omega$
- D $18.4\ \Omega$
- E $57.5\ \Omega$.

5. A syringe containing air is sealed at one end as shown.

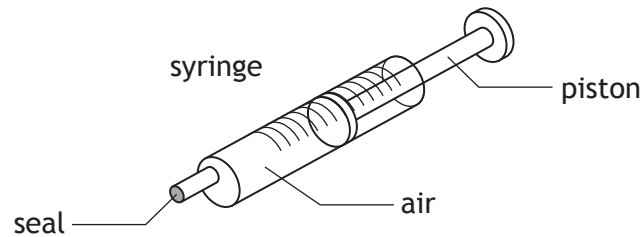

The piston is pushed in slowly.

There is no change in temperature of the air inside the syringe.

Which of the following statements describes and explains the change in pressure of the air in the syringe?

- A The pressure increases because the air particles have more kinetic energy.
 - B The pressure increases because the air particles hit the sides of the syringe more frequently.
 - C The pressure increases because the air particles hit the sides of the syringe less frequently.
 - D The pressure decreases because the air particles hit the sides of the syringe with less force.
 - E The pressure decreases because the air particles have less kinetic energy.
6. The pressure of a fixed mass of gas is 150 kPa at a temperature of 27 °C.
The temperature of the gas is now increased to 47 °C.
The volume of the gas remains constant.
The pressure of the gas is now
- A 86 kPa
 - B 141 kPa
 - C 150 kPa
 - D 160 kPa
 - E 261 kPa.

[Turn over

7. The diagram represents a water wave.

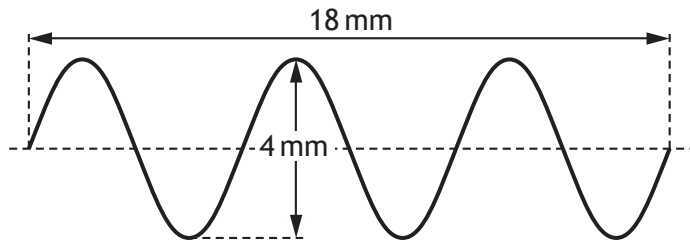

The wavelength of the water wave is

- A 2 mm
 - B 3 mm
 - C 4 mm
 - D 6 mm
 - E 18 mm.
8. A student makes the following statements about different types of electromagnetic waves.
- I Light waves are transverse waves.
 - II Radio waves travel at 340 m s^{-1} through air.
 - III Ultraviolet waves have a longer wavelength than infrared waves.
- Which of these statements is/are correct?
- A I only
 - B I and II only
 - C I and III only
 - D II and III only
 - E I, II and III
9. Alpha radiation ionises an atom.
- Which statement describes what happens to the atom?
- A The atom splits in half.
 - B The atom releases a neutron.
 - C The atom becomes positively charged.
 - D The atom gives out gamma radiation.
 - E The atom releases heat.

10. A sample of tissue is irradiated using a radioactive source.
A student makes the following statements.
The equivalent dose received by the tissue is
- I reduced by shielding the tissue with a lead screen
 - II increased as the distance from the source to the tissue is increased
 - III increased by increasing the time of exposure of the tissue to the radiation.
- Which of the statements is/are correct?
- A I only
 - B II only
 - C I and II only
 - D II and III only
 - E I and III only
11. A sample of tissue receives an absorbed dose of $16 \mu\text{Gy}$ from alpha particles.
The radiation weighting factor for alpha particles is 20.
The equivalent dose received by the sample is
- A $0.80 \mu\text{Sv}$
 - B $1.25 \mu\text{Sv}$
 - C $4 \mu\text{Sv}$
 - D $36 \mu\text{Sv}$
 - E $320 \mu\text{Sv}$.
12. For a particular radioactive source, 240 atoms decay in 1 minute.
The activity of this source is
- A 4 Bq
 - B 180 Bq
 - C 240 Bq
 - D 300 Bq
 - E 14 400 Bq.

[Turn over

13. The letters X, Y and Z represent missing words from the following passage.

During a nuclearX..... reaction two nuclei of smaller mass number combine to produce a nucleus of larger mass number. During a nuclearY..... reaction a nucleus of larger mass number splits into two nuclei of smaller mass number. Both of these reactions are important because these processes can releaseZ..... .

Which row in the table shows the missing words?

	X	Y	Z
A	fusion	fission	electrons
B	fission	fusion	energy
C	fusion	fission	protons
D	fission	fusion	protons
E	fusion	fission	energy

14. Which of the following quantities is fully described by its magnitude?

- A Force
- B Displacement
- C Energy
- D Velocity
- E Acceleration

15. The table shows the velocities of three objects X, Y and Z over a period of 3 seconds. Each object is moving in a straight line.

Time (s)	0	1	2	3
Velocity of X (m s^{-1})	2	4	6	8
Velocity of Y (m s^{-1})	0	1	2	3
Velocity of Z (m s^{-1})	0	2	5	9

Which of the following statements is/are correct?

- I X moves with constant velocity.
 - II Y moves with constant acceleration.
 - III Z moves with constant acceleration.
- A I only
B II only
C I and II only
D I and III only
E II and III only
16. A car of mass 1200 kg is travelling along a straight level road at a constant speed of 20 m s^{-1} .

The driving force on the car is 2500 N. The frictional force on the car is 2500 N.

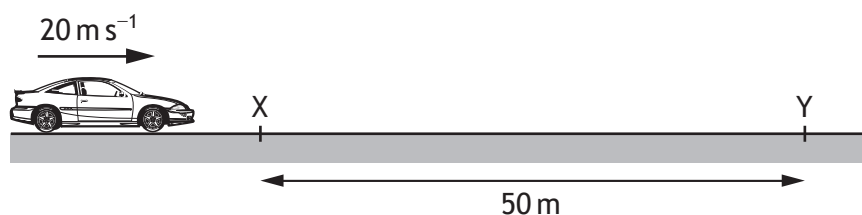

The work done moving the car between point X and point Y is

- A 0 J
B 11 800 J
C 125 000 J
D 240 000 J
E 250 000 J.

[Turn over

17. A person sits on a chair which rests on the Earth. The person exerts a downward force on the chair.



Which of the following is the reaction to this force?

- A The force of the chair on the person
 - B The force of the person on the chair
 - C The force of the Earth on the person
 - D The force of the chair on the Earth
 - E The force of the person on the Earth
18. A package falls vertically from a helicopter. After some time the package reaches its terminal velocity.

A group of students make the following statements about the package when it reaches its terminal velocity.

- I The weight of the package is less than the air resistance acting on the package.
- II The forces acting on the package are balanced.
- III The package is accelerating towards the ground at 9.8 m s^{-2} .

Which of these statements is/are correct?

- A I only
- B II only
- C III only
- D I and III only
- E II and III only

19. The distance from the Sun to Proxima Centauri is 4.3 light years.
This distance is equivalent to

- A 1.4×10^8 m
- B 1.6×10^{14} m
- C 6.8×10^{14} m
- D 9.5×10^{15} m
- E 4.1×10^{16} m.

20. Light from a star is split into a line spectrum of different colours. The line spectrum from the star is shown, along with the line spectra of the elements calcium, helium, hydrogen and sodium.

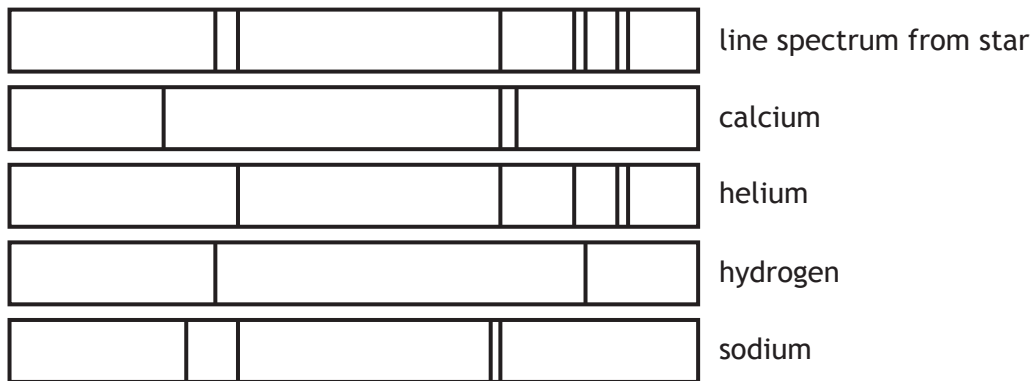

The elements present in this star are

- A sodium and calcium
- B calcium and helium
- C hydrogen and sodium
- D helium and hydrogen
- E calcium, sodium and hydrogen.

[END OF SECTION 1. NOW ATTEMPT THE QUESTIONS IN SECTION 2
OF YOUR QUESTION AND ANSWER BOOKLET]

ACKNOWLEDGEMENTS

Question 17 – Rob Byron/shutterstock.com

FOR OFFICIAL USE



National
Qualifications
2015

Mark

X757/75/01

**Physics
Section 1—Answer Grid
and Section 2**

TUESDAY, 5 MAY

9:00 AM – 11:00 AM



* X 7 5 7 7 5 0 1 *

Fill in these boxes and read what is printed below.

Full name of centre

Town

Forename(s)

Surname

Number of seat

Date of birth

Day

Month

Year

Scottish candidate number

Total marks — 110

SECTION 1 — 20 marks

Attempt ALL questions.

Instructions for the completion of Section 1 are given on *Page two*.

SECTION 2 — 90 marks

Attempt ALL questions.

Reference may be made to the Data Sheet on *Page two* of the question paper X757/75/02 and to the Relationship Sheet X757/75/11.

Care should be taken to give an appropriate number of significant figures in the final answers to calculations.

Write your answers clearly in the spaces provided in this booklet. Additional space for answers and rough work is provided at the end of this booklet. If you use this space you must clearly identify the question number you are attempting. Any rough work must be written in this booklet. You should score through your rough work when you have written your final copy.

Use **blue** or **black** ink.

Before leaving the examination room you must give this booklet to the Invigilator; if you do not, you may lose all the marks for this paper.



* X 7 5 7 7 5 0 1 0 1 *

The questions for Section 1 are contained in the question paper X757/75/02.
Read these and record your answers on the answer grid on *Page three* opposite.
Use **blue** or **black** ink. Do NOT use gel pens or pencil.

1. The answer to each question is **either** A, B, C, D or E. Decide what your answer is, then fill in the appropriate bubble (see sample question below).
2. There is **only one correct** answer to each question.
3. Any rough work must be written in the additional space for answers and rough work at the end of this booklet.

Sample Question

The energy unit measured by the electricity meter in your home is the:

- A ampere
- B kilowatt-hour
- C watt
- D coulomb
- E volt.

The correct answer is **B**—kilowatt-hour. The answer **B** bubble has been clearly filled in (see below).

A	B	C	D	E
<input type="radio"/>	<input checked="" type="radio"/>	<input type="radio"/>	<input type="radio"/>	<input type="radio"/>

Changing an answer

If you decide to change your answer, cancel your first answer by putting a cross through it (see below) and fill in the answer you want. The answer below has been changed to **D**.

A	B	C	D	E
<input type="radio"/>	<input checked="" type="radio"/>	<input type="radio"/>	<input checked="" type="radio"/>	<input type="radio"/>

If you then decide to change back to an answer you have already scored out, put a tick (✓) to the **right** of the answer you want, as shown below:

A	B	C	D	E	or	A	B	C	D	E
<input type="radio"/>	<input checked="" type="radio"/>	<input type="radio"/>	<input checked="" type="radio"/>	<input type="radio"/>		<input type="radio"/>	<input checked="" type="radio"/>	<input type="radio"/>	<input type="radio"/>	<input type="radio"/>



SECTION 1 — Answer Grid



* 0 B J 2 0 A E 1 *

	A	B	C	D	E
1	<input type="radio"/>	<input type="radio"/>	<input type="radio"/>	<input type="radio"/>	<input type="radio"/>
2	<input type="radio"/>	<input type="radio"/>	<input type="radio"/>	<input type="radio"/>	<input type="radio"/>
3	<input type="radio"/>	<input type="radio"/>	<input type="radio"/>	<input type="radio"/>	<input type="radio"/>
4	<input type="radio"/>	<input type="radio"/>	<input type="radio"/>	<input type="radio"/>	<input type="radio"/>
5	<input type="radio"/>	<input type="radio"/>	<input type="radio"/>	<input type="radio"/>	<input type="radio"/>
6	<input type="radio"/>	<input type="radio"/>	<input type="radio"/>	<input type="radio"/>	<input type="radio"/>
7	<input type="radio"/>	<input type="radio"/>	<input type="radio"/>	<input type="radio"/>	<input type="radio"/>
8	<input type="radio"/>	<input type="radio"/>	<input type="radio"/>	<input type="radio"/>	<input type="radio"/>
9	<input type="radio"/>	<input type="radio"/>	<input type="radio"/>	<input type="radio"/>	<input type="radio"/>
10	<input type="radio"/>	<input type="radio"/>	<input type="radio"/>	<input type="radio"/>	<input type="radio"/>
11	<input type="radio"/>	<input type="radio"/>	<input type="radio"/>	<input type="radio"/>	<input type="radio"/>
12	<input type="radio"/>	<input type="radio"/>	<input type="radio"/>	<input type="radio"/>	<input type="radio"/>
13	<input type="radio"/>	<input type="radio"/>	<input type="radio"/>	<input type="radio"/>	<input type="radio"/>
14	<input type="radio"/>	<input type="radio"/>	<input type="radio"/>	<input type="radio"/>	<input type="radio"/>
15	<input type="radio"/>	<input type="radio"/>	<input type="radio"/>	<input type="radio"/>	<input type="radio"/>
16	<input type="radio"/>	<input type="radio"/>	<input type="radio"/>	<input type="radio"/>	<input type="radio"/>
17	<input type="radio"/>	<input type="radio"/>	<input type="radio"/>	<input type="radio"/>	<input type="radio"/>
18	<input type="radio"/>	<input type="radio"/>	<input type="radio"/>	<input type="radio"/>	<input type="radio"/>
19	<input type="radio"/>	<input type="radio"/>	<input type="radio"/>	<input type="radio"/>	<input type="radio"/>
20	<input type="radio"/>	<input type="radio"/>	<input type="radio"/>	<input type="radio"/>	<input type="radio"/>



* X 7 5 7 7 5 0 1 0 3 *

[BLANK PAGE]

DO NOT WRITE ON THIS PAGE



* X 7 5 7 7 5 0 1 0 4 *

MARKS

DO NOT
WRITE IN
THIS
MARGIN

[Turn over for Question 1 on *Page six*

DO NOT WRITE ON THIS PAGE



* X 7 5 7 7 5 0 1 0 5 *

SECTION 2 — 90 marks

Attempt ALL questions

MARKS
DO NOT
WRITE IN
THIS
MARGIN

1. A student sets up the following circuit using a battery, two lamps, a switch and a resistor.

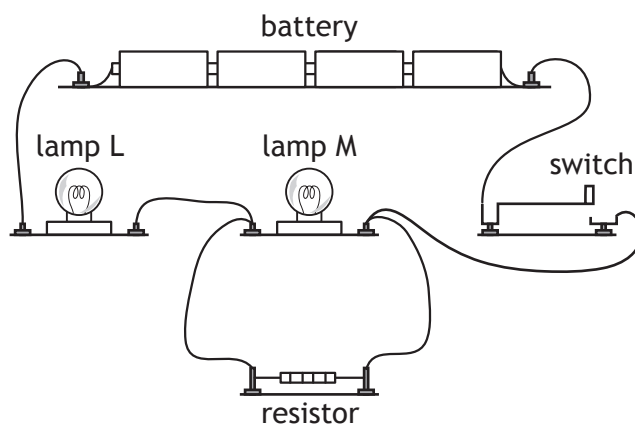

- (a) Draw a circuit diagram for this circuit using the correct symbols for the components.

3

- (b) Each lamp is rated 2.5 V, 0.50 A.

Calculate the resistance of one of the lamps when it is operating at the correct voltage.

3

Space for working and answer



MARKS

DO NOT
WRITE IN
THIS
MARGIN

1. (continued)

- (c) When the switch is closed, will lamp L be brighter, dimmer or the same brightness as lamp M?

You must justify your answer.

3

[Turn over



* X 7 5 7 7 5 0 1 0 7 *

2. (a) A student investigates the electrical properties of three different components; a lamp, an LED and a fixed resistor.

Current-voltage graphs produced from the student's results are shown.

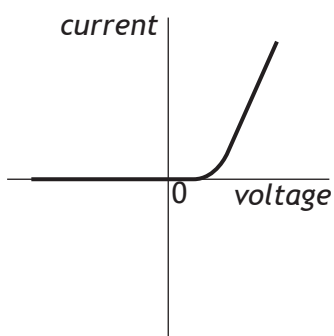

Graph X

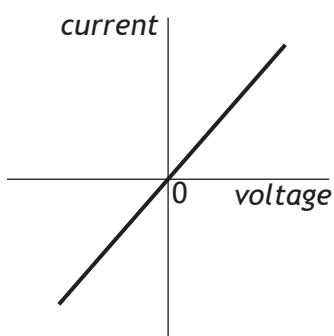

Graph Y

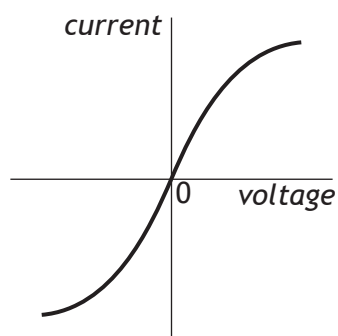

Graph Z

Explain which graph X, Y or Z is obtained from the student's results for the LED.

2

- (b) One of the components is operated at 4.0V with a current of 0.50A for 60 seconds.

- (i) Calculate the energy transferred to the component during this time.

4

Space for working and answer



MARKS

DO NOT
WRITE IN
THIS
MARGIN

2. (b) (continued)

- (ii) Calculate the charge which passes through this component during this time.

3

Space for working and answer

[Turn over



* X 7 5 7 7 5 0 1 0 9 *

3. A technician uses pulses of ultrasound (high frequency sound) to detect imperfections in a sample of steel.

The pulses of ultrasound are transmitted into the steel.

The speed of ultrasound in steel is 5200 ms^{-1} .

Where there are no imperfections, the pulses of ultrasound travel through the steel and are reflected by the back wall of the steel.

Where there are imperfections in the steel, the pulses of ultrasound are reflected by these imperfections.

The reflected pulses return through the sample and are detected by the ultrasound receiver.

The technician transmits pulses of ultrasound into the steel at positions X, Y and Z as shown.

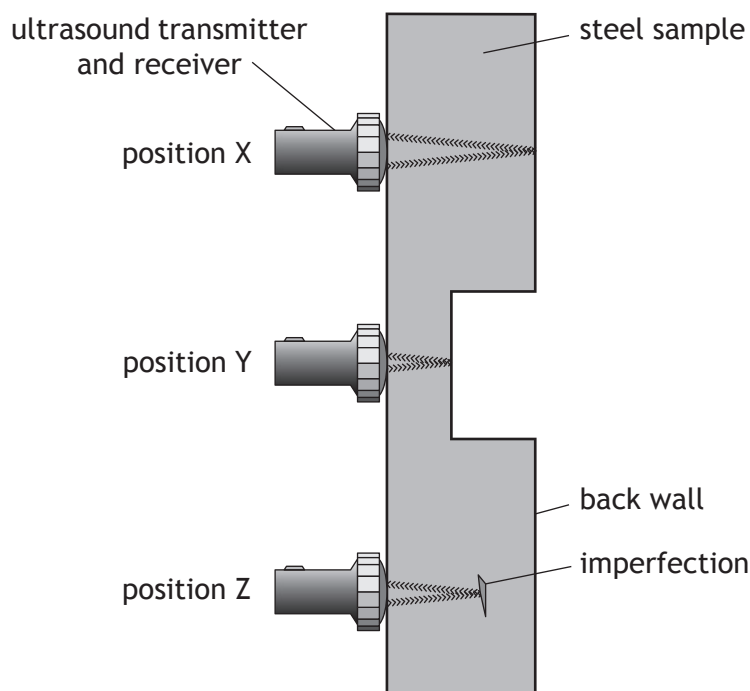

The times between the pulses being transmitted and received for positions X and Y are shown in the graph.

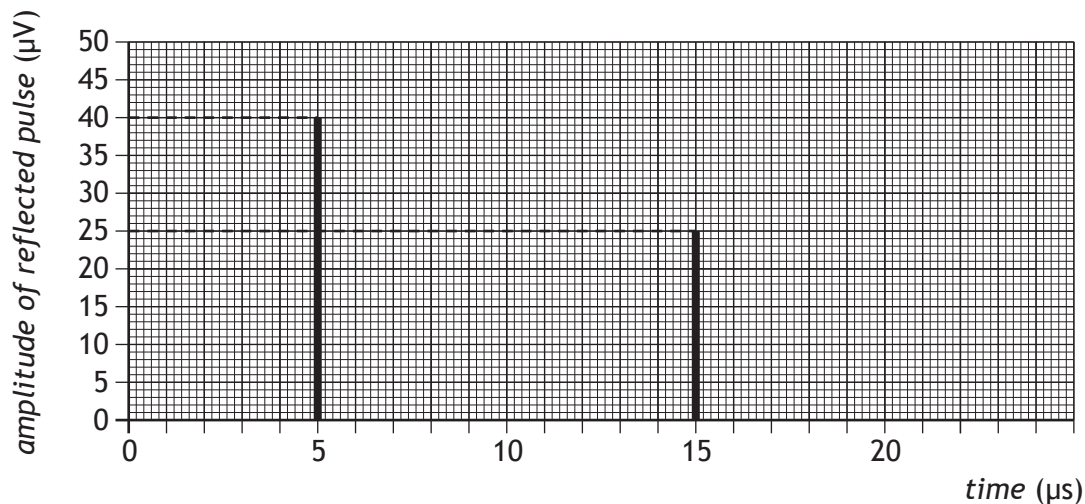

3. (continued)

MARKS

DO NOT
WRITE IN
THIS
MARGIN

(a) (i) State the time taken between the pulse being transmitted and received at position X.

1

(ii) Calculate the thickness of the steel sample at position X.

4

Space for working and answer

(b) On the graph on the previous page, draw a line to show the reflected pulse from position Z.

2

(c) The ultrasound pulses used have a period of $4.0 \mu\text{s}$.

(i) Show that the frequency of the ultrasound pulses is $2.5 \times 10^5 \text{ Hz}$.

2

Space for working and answer

(ii) Calculate the wavelength of the ultrasound pulses in the steel sample.

3

Space for working and answer



* X 7 5 7 7 5 0 1 1 1 *

3. (continued)

(d) The technician replaces the steel sample with a brass sample.

The brass sample has the same thickness as the steel sample at position X.

The technician transmits pulses of ultrasound into the brass at position P as shown.

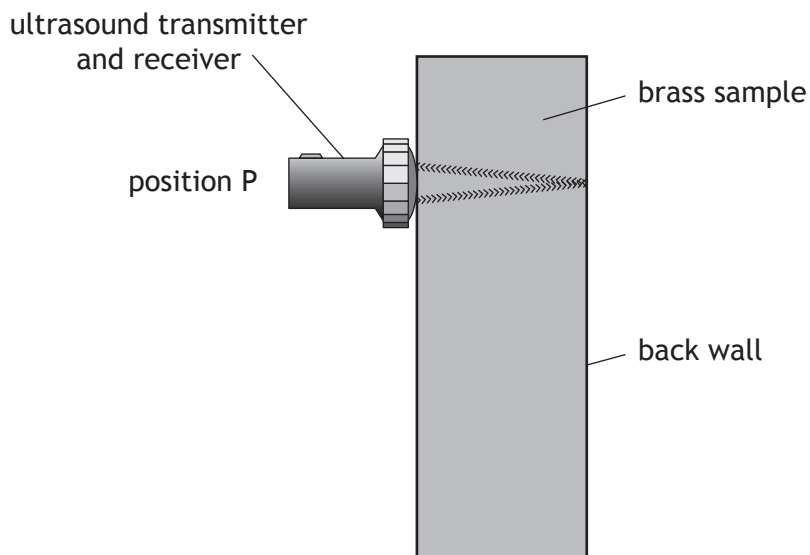

The time between the ultrasound pulse being transmitted and received at position P is greater than the time recorded at position X in the steel sample.

State whether the speed of ultrasound in brass is less than, equal to or greater than the speed of ultrasound in steel.

You **must** justify your answer.

2



MARKS DO NOT WRITE IN THIS MARGIN

4. A science technician removes two metal blocks from an oven. Immediately after the blocks are removed from the oven the technician measures the temperature of each block, using an infrared thermometer. The temperature of each block is 230°C .

After several minutes the temperature of each block is measured again. One block is now at a temperature of 123°C and the other block is at a temperature of 187°C .

Using your knowledge of physics, comment on possible explanations for this difference in temperature.

3

[Turn over



* X 7 5 7 7 5 0 1 1 3 *

5. Diamonds are popular and sought after gemstones. Light is refracted as it enters and leaves a diamond. The diagram shows a ray of light entering a diamond.

MARKS DO NOT WRITE IN THIS MARGIN

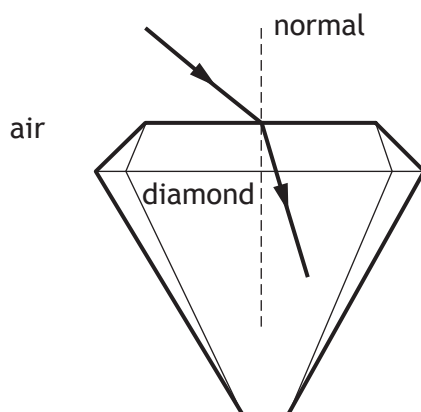

- (a) On the diagram, label the angle of incidence i and the angle of refraction r . 1
- (b) State what happens to the speed of the light as it enters the diamond. 1

- (c) The optical density of a gemstone is a measure of its ability to refract light.

Gemstones of higher optical density cause more refraction.

A ray of light is directed into a gemstone at an angle of incidence of 45° .

The angle of refraction is then measured.

This is repeated for different gemstones.

Gemstone	Angle of refraction
A	24.3°
B	17.0°
C	27.3°
D	19.0°
E	25.5°

Diamond is known to have the highest optical density. Identify which gemstone is most likely to be diamond. 1



5. (continued)

- (d) Diamond is one of the hardest known substances.

Synthetic diamonds are attached to the cutting edges of drill bits for use in the oil industry.

These drill bits are able to cut into rock.

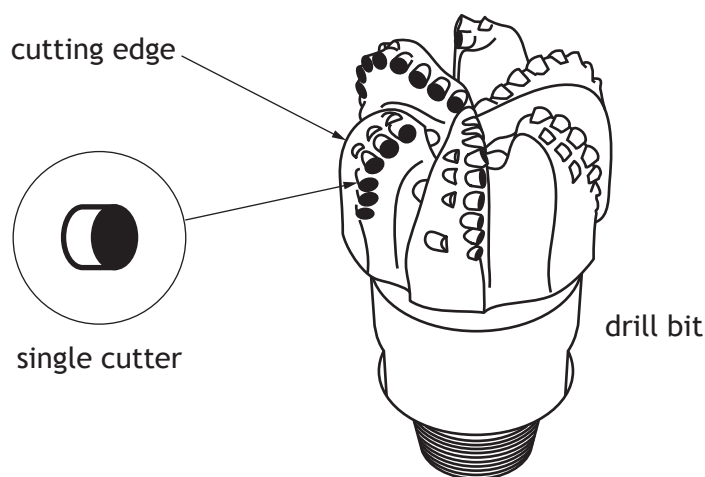

The area of a single cutter in contact with the rock is $1.1 \times 10^{-5} \text{ m}^2$.

When drilling, this cutter is designed to exert a maximum force of 61 kN on the rock.

Calculate the maximum pressure that the cutter can exert on the rock.

3

Space for working and answer

[Turn over



6. A paper mill uses a radioactive source in a system to monitor the thickness of paper.

MARKS

DO NOT
WRITE IN
THIS
MARGIN

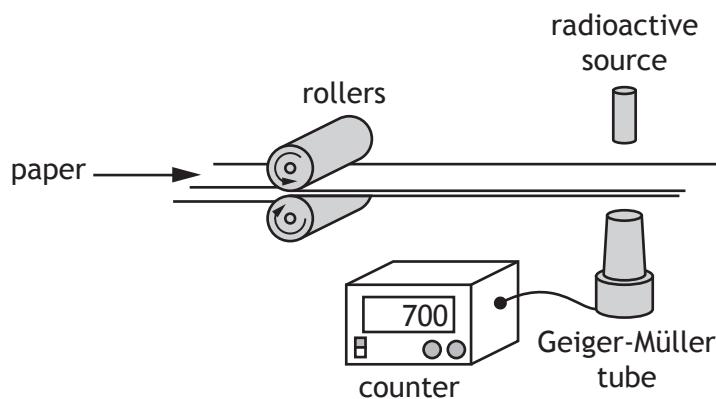

Radiation passing through the paper is detected by the Geiger-Müller tube. The count rate is displayed on the counter as shown. The radioactive source has a half-life that allows the system to run continuously.

- (a) State what happens to the count rate if the thickness of the paper decreases.

1

- (b) The following radioactive sources are available.

<i>Radioactive Source</i>	<i>Half-life</i>	<i>Radiation emitted</i>
W	600 years	alpha
X	50 years	beta
Y	4 hours	beta
Z	350 years	gamma

- (i) State which radioactive source should be used.
You **must** explain your answer.

3



* X 7 5 7 7 5 0 1 1 6 *

6. (b) (continued)

(ii) State what is meant by the term *half-life*.

1

(iii) State what is meant by a gamma ray.

1

(c) The graph below shows how the activity of another radioactive source varies with time.

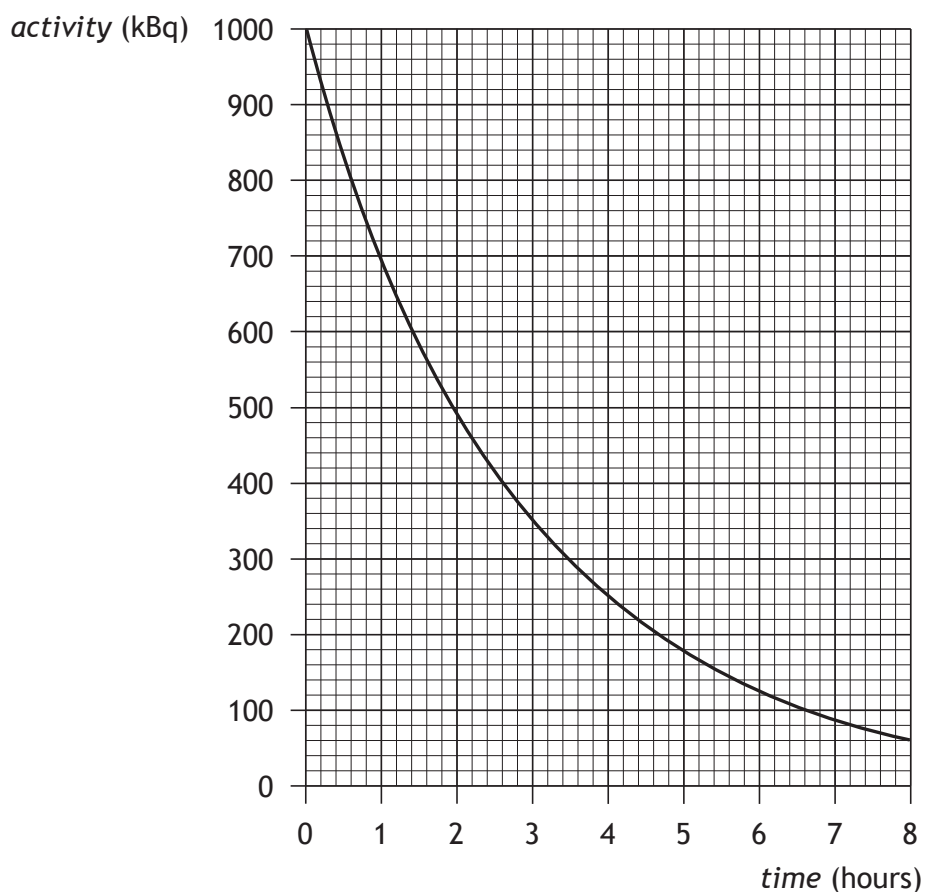

Determine the half-life of this radioactive source.

1

[Turn over



* X 7 5 7 7 5 0 1 1 7 *

7. A ship of mass 5.0×10^6 kg leaves a port. Its engine produces a forward force of 8.0×10^3 N. A tugboat pushes against one side of the ship as shown. The tugboat applies a pushing force of 6.0×10^3 N.

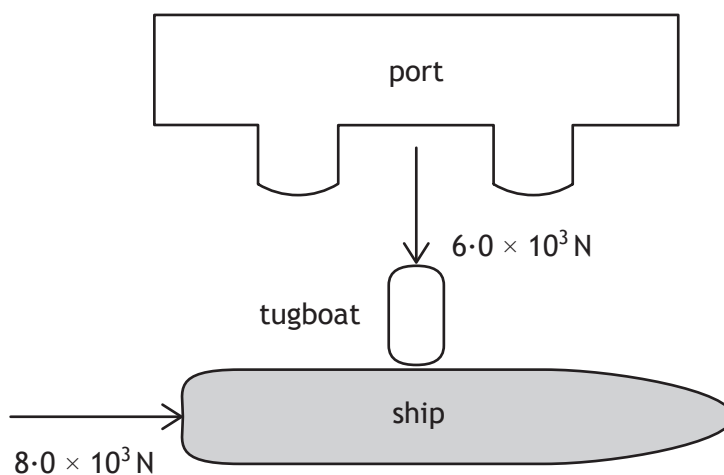

- (a) (i) By scale drawing, or otherwise, determine the size of the resultant force acting on the ship. 2

Space for working and answer

- (ii) Determine the direction of the resultant force relative to the 8.0×10^3 N force. 2

Space for working and answer



MARKS

DO NOT
WRITE IN
THIS
MARGIN

7. (a) (continued)

(iii) Calculate the size of the acceleration of the ship.

Space for working and answer

3

(b) Out in the open sea the ship comes to rest.

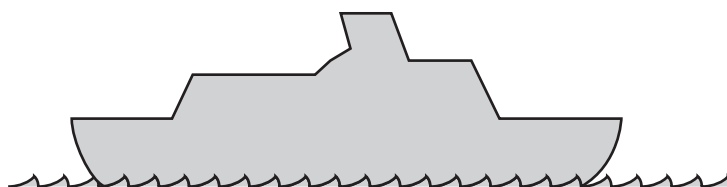

Explain, with the aid of a labelled diagram, why the ship floats.

3

[Turn over



* X 7 5 7 7 5 0 1 1 9 *

8. A student is investigating the motion of a trolley down a ramp.

MARKS
DO NOT
WRITE IN
THIS
MARGIN

(a) The student uses the apparatus shown to carry out an experiment to determine the acceleration of a trolley as it rolls down a ramp.

The trolley is released from rest at the top of the ramp.

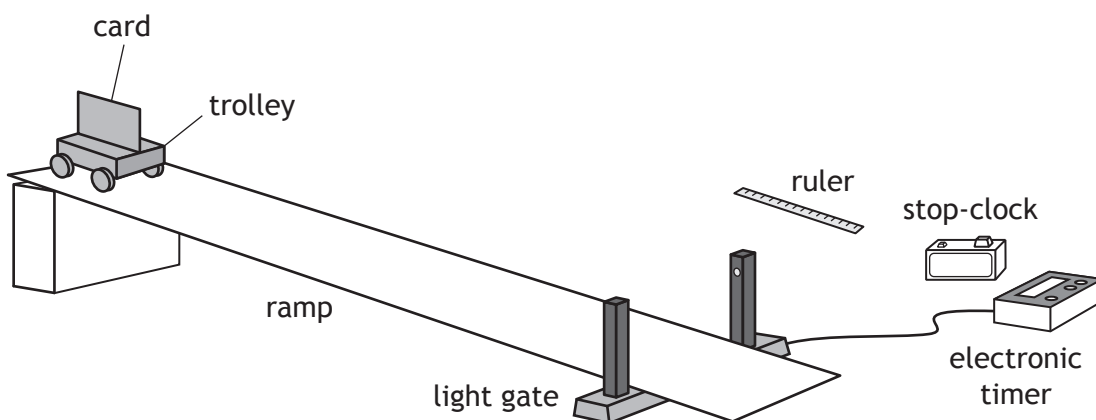

(i) State the measurements the student must make to calculate the acceleration of the trolley.

3

(ii) Suggest one reason why the acceleration calculated from these measurements might not be accurate.

1



8. (continued)

(b) In a second experiment, the student uses a motion sensor and computer to produce the following velocity-time graph for the trolley

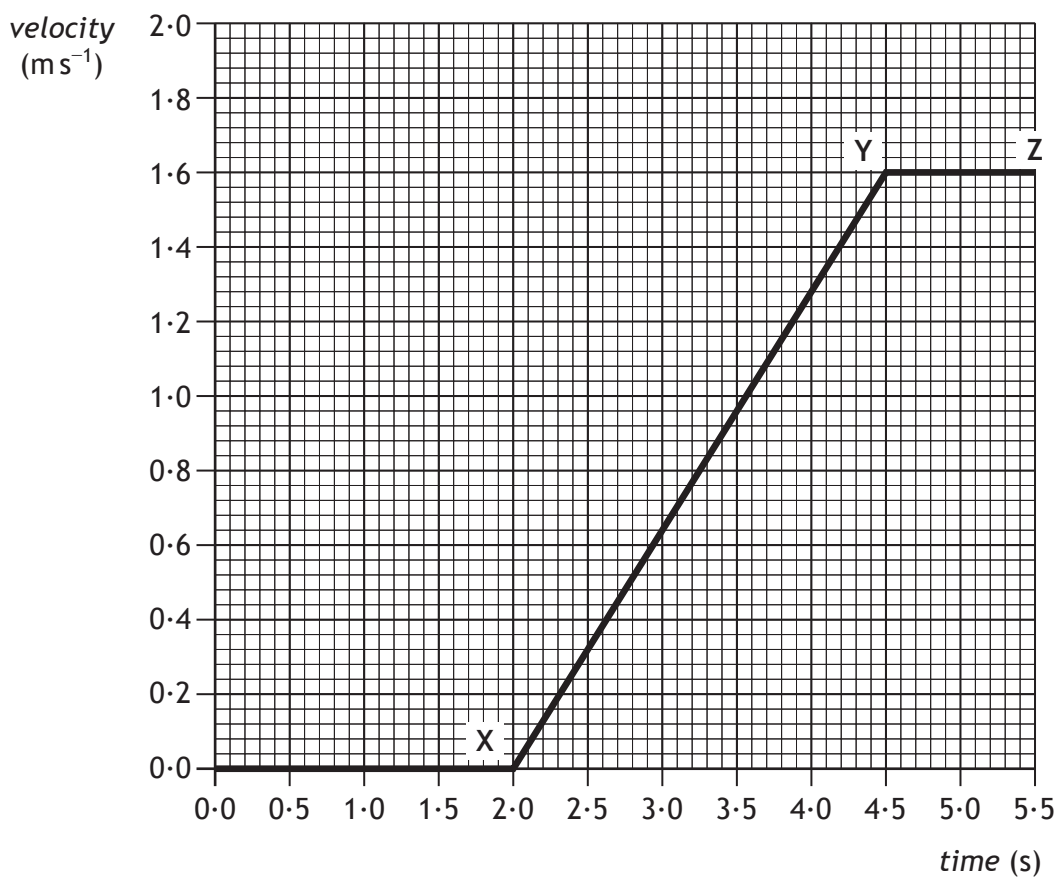

Calculate the acceleration of this trolley between X and Y.

3

Space for working and answer

[Turn over



9. A child throws a stone horizontally from a bridge into a river.

MARKS
DO NOT
WRITE IN
THIS
MARGIN

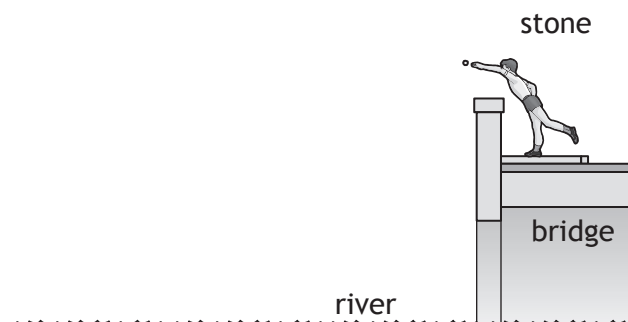

(a) On the above diagram sketch the path taken by the stone between leaving the child's hand and hitting the water. 1

(b) The stone reaches the water 0.80 s after it was released.

(i) Calculate the vertical velocity of the stone as it reaches the water.
The effects of air resistance can be ignored. 3

Space for working and answer

(ii) Determine the height above the water at which the stone was released. 4

Space for working and answer

(c) The child now drops a similar stone vertically from the same height into the river.

State how the time taken for this stone to reach the water compares with the time taken for the stone in (b). 1



* X 7 5 7 7 5 0 1 2 2 *

MARKS

DO NOT
WRITE IN
THIS
MARGIN

10. Space exploration involves placing astronauts in difficult environments. Despite this, many people believe the benefits of space exploration outweigh the risks.

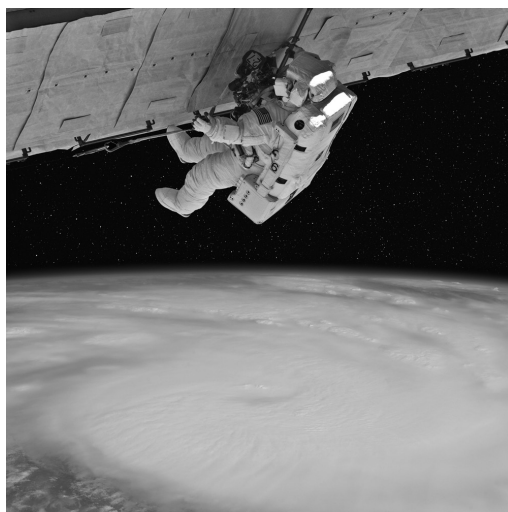

Using your knowledge of physics, comment on the benefits and/or risks of space exploration.

3

[Turn over



* X 7 5 7 7 5 0 1 2 3 *

[BLANK PAGE]

DO NOT WRITE ON THIS PAGE



* X 7 5 7 7 5 0 1 2 4 *

11. Craters on the Moon are caused by meteors striking its surface.

MARKS
DO NOT
WRITE IN
THIS
MARGIN



A student investigates how a crater is formed by dropping a marble into a tray of sand.

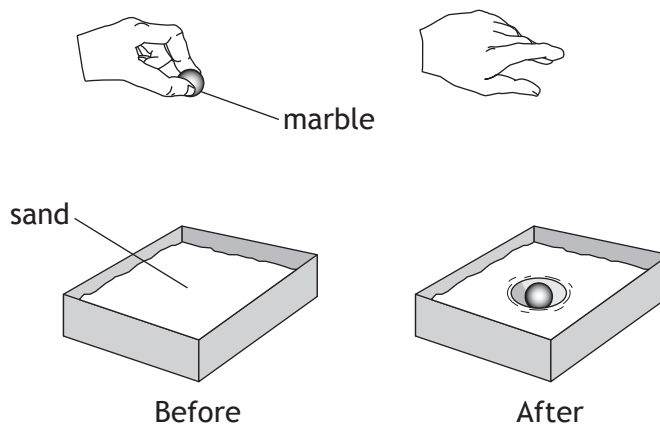

(a) The marble has a mass of 0.040 kg.

(i) Calculate the loss in potential energy of the marble when it is dropped from a height of 0.50 m.

3

Space for working and answer

(ii) Describe the energy change that takes place as the marble hits the sand.

1

[Turn over



11. (continued)

MARKS DO NOT WRITE IN THIS MARGIN

- (b) The student drops the marble from different heights and measures the diameter of each crater that is formed.

The table shows the student's results.

<i>height (m)</i>	<i>diameter (m)</i>
0.05	0.030
0.10	0.044
0.15	0.053
0.35	0.074
0.40	0.076
0.45	0.076

- (i) Using the graph paper below, draw a graph of these results.

3

(Additional graph paper, if required, can be found on *Page twenty-eight*)

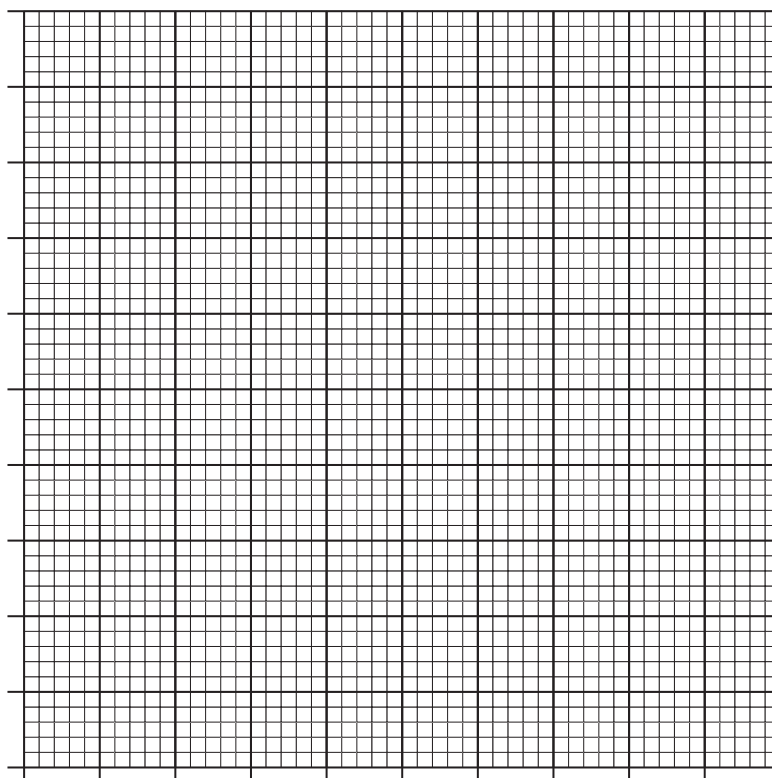

11. (b) (continued)

- (ii) Use your graph to predict the diameter of the crater that is formed when the marble is dropped from a height of 0.25 m. 1

- (iii) Suggest two improvements that the student could make to this investigation. 2

- (c) (i) Suggest another variable, which could be investigated, that may affect the diameter of a crater. 1

- (ii) Describe experimental work that could be carried out to investigate how this variable affects the diameter of a crater. 2

[END OF QUESTION PAPER]



* X 7 5 7 7 5 0 1 2 7 *



ADDITIONAL SPACE FOR ANSWERS AND ROUGH WORKING

MARKS DO NOT
WRITE IN
THIS
MARGIN

Additional graph paper for Q11 (b) (i)

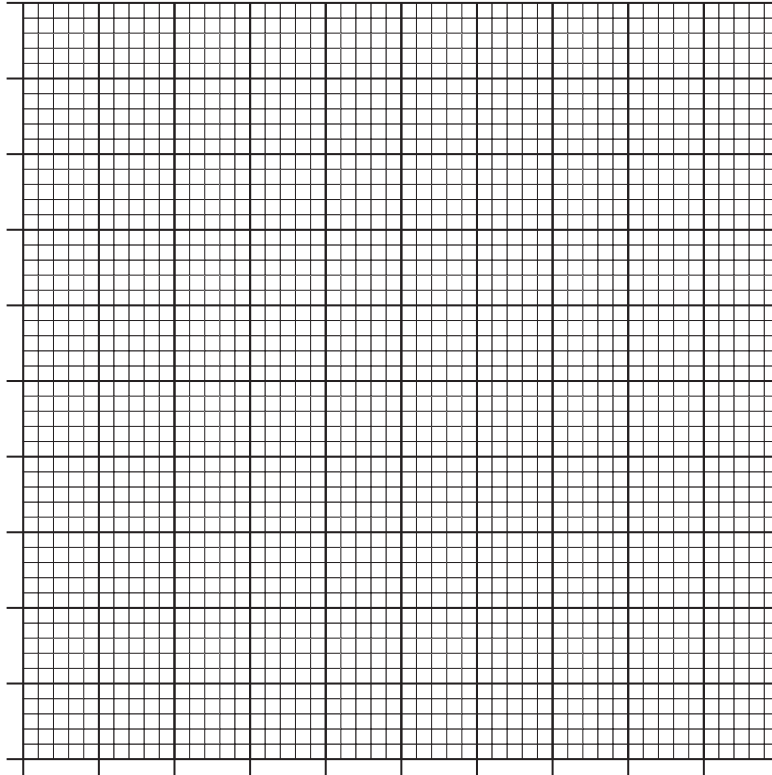

--



* X 7 5 7 7 5 0 1 2 8 *



ADDITIONAL SPACE FOR ANSWERS AND ROUGH WORKING

MARKS

DO NOT
WRITE IN
THIS
MARGIN

--



* X 7 5 7 7 5 0 1 2 9 *



ADDITIONAL SPACE FOR ANSWERS AND ROUGH WORKING

MARKS

DO NOT
WRITE IN
THIS
MARGIN

--



* X 7 5 7 7 5 0 1 3 0 *

[BLANK PAGE]

DO NOT WRITE ON THIS PAGE



* X 7 5 7 7 5 0 1 3 1 *

ACKNOWLEDGEMENTS

Question 10 – MarcelClemens/shutterstock.com

Question 11 – Procy/shutterstock.com



* X 7 5 7 7 5 0 1 3 2 *