



National  
Qualifications  
2017

**X757/75/02**

**Physics**  
**Section 1 — Questions**

WEDNESDAY, 17 MAY

1:00 PM – 3:00 PM

Instructions for the completion of Section 1 are given on *Page 02* of your question and answer booklet X757/75/01.

Record your answers on the answer grid on *Page 03* of your question and answer booklet.

Reference may be made to the Data Sheet on *Page 02* of this booklet and to the Relationship Sheet X757/75/11.

Before leaving the examination room you must give your question and answer booklet to the Invigilator; if you do not, you may lose all the marks for this paper.



\* X 7 5 7 7 5 0 2 \*

## DATA SHEET

### Speed of light in materials

Material	Speed in $\text{m s}^{-1}$
Air	$3.0 \times 10^8$
Carbon dioxide	$3.0 \times 10^8$
Diamond	$1.2 \times 10^8$
Glass	$2.0 \times 10^8$
Glycerol	$2.1 \times 10^8$
Water	$2.3 \times 10^8$

### Speed of sound in materials

Material	Speed in $\text{m s}^{-1}$
Aluminium	5200
Air	340
Bone	4100
Carbon dioxide	270
Glycerol	1900
Muscle	1600
Steel	5200
Tissue	1500
Water	1500

### Gravitational field strengths

	Gravitational field strength on the surface in $\text{N kg}^{-1}$
Earth	9.8
Jupiter	23
Mars	3.7
Mercury	3.7
Moon	1.6
Neptune	11
Saturn	9.0
Sun	270
Uranus	8.7
Venus	8.9

### Specific heat capacity of materials

Material	Specific heat capacity in $\text{J kg}^{-1} \text{ } ^\circ\text{C}^{-1}$
Alcohol	2350
Aluminium	902
Copper	386
Glass	500
Ice	2100
Iron	480
Lead	128
Oil	2130
Water	4180

### Specific latent heat of fusion of materials

Material	Specific latent heat of fusion in $\text{J kg}^{-1}$
Alcohol	$0.99 \times 10^5$
Aluminium	$3.95 \times 10^5$
Carbon Dioxide	$1.80 \times 10^5$
Copper	$2.05 \times 10^5$
Iron	$2.67 \times 10^5$
Lead	$0.25 \times 10^5$
Water	$3.34 \times 10^5$

### Melting and boiling points of materials

Material	Melting point in $^\circ\text{C}$	Boiling point in $^\circ\text{C}$
Alcohol	-98	65
Aluminium	660	2470
Copper	1077	2567
Glycerol	18	290
Lead	328	1737
Iron	1537	2737

### Specific latent heat of vaporisation of materials

Material	Specific latent heat of vaporisation in $\text{J kg}^{-1}$
Alcohol	$11.2 \times 10^5$
Carbon Dioxide	$3.77 \times 10^5$
Glycerol	$8.30 \times 10^5$
Turpentine	$2.90 \times 10^5$
Water	$22.6 \times 10^5$

### Radiation weighting factors

Type of radiation	Radiation weighting factor
alpha	20
beta	1
fast neutrons	10
gamma	1
slow neutrons	3
X-rays	1

SECTION 1

Attempt ALL questions

1. A cyclist is travelling along a straight road. The graph shows how the velocity of the cyclist varies with time.

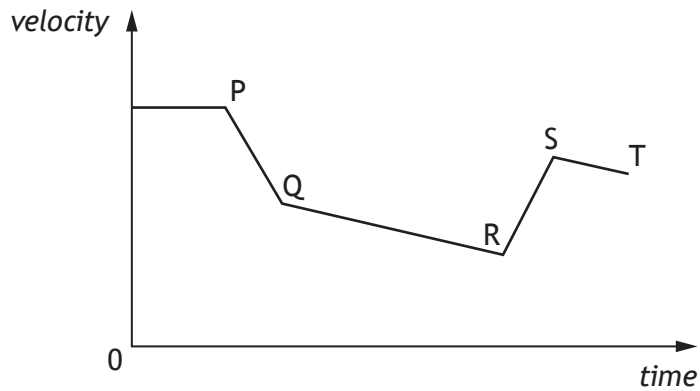

The kinetic energy of the cyclist is greatest at

- A P
  - B Q
  - C R
  - D S
  - E T.
2. A circuit is set up as shown.

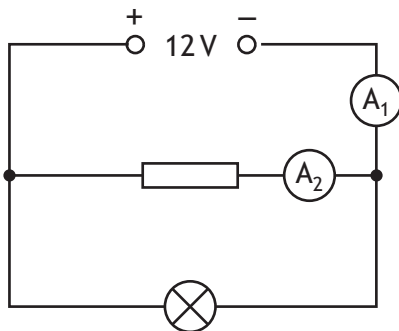

The reading on ammeter  $A_1$  is 5.0 A. The reading on ammeter  $A_2$  is 2.0 A.

The charge passing through the lamp in 30 seconds is

- A 0.1 C
- B 10 C
- C 60 C
- D 90 C
- E 150 C.

3. A lamp is connected to a constant voltage power supply. The power supply is switched on. The graph shows how the current in the lamp varies with time.

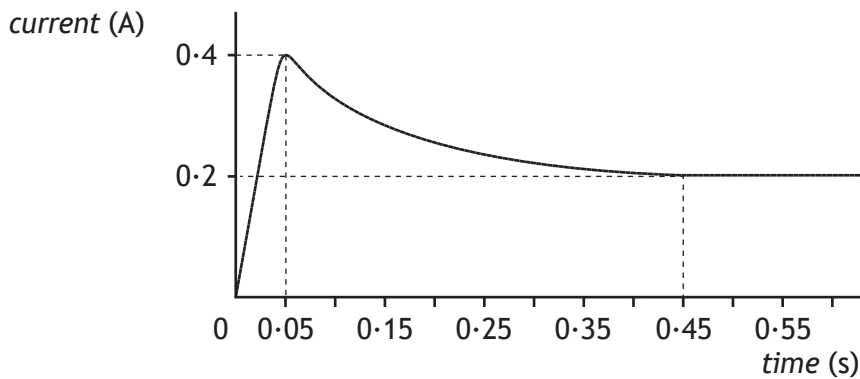

Which row in the table shows what happens to the current and resistance of the lamp between 0.05 s and 0.45 s?

	<i>Current</i>	<i>Resistance</i>
A	decreases	increases
B	decreases	stays the same
C	stays the same	decreases
D	increases	decreases
E	increases	increases

4. A circuit is set up as shown.

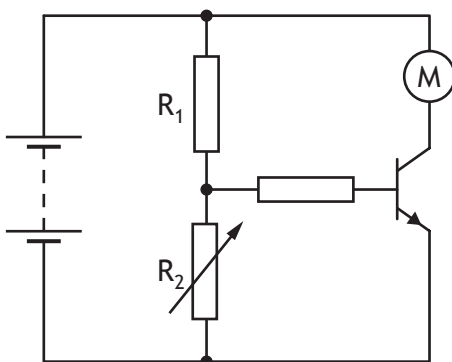

The purpose of the transistor is to

- A supply energy to the circuit
- B decrease the voltage across  $R_1$
- C change electrical energy to kinetic energy
- D supply energy to the motor
- E switch on the motor.

5. Five students each carry out an experiment to determine the specific heat capacity of copper. The setup used by each student is shown.

Student 1

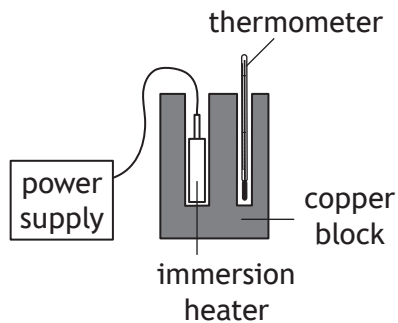

Student 2

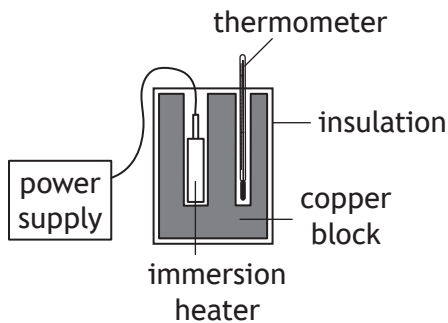

Student 3

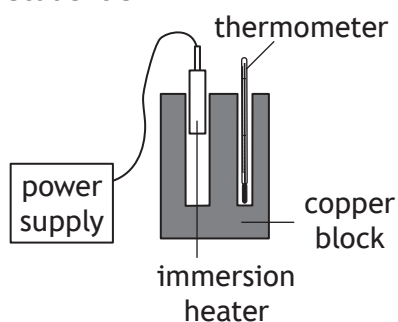

Student 4

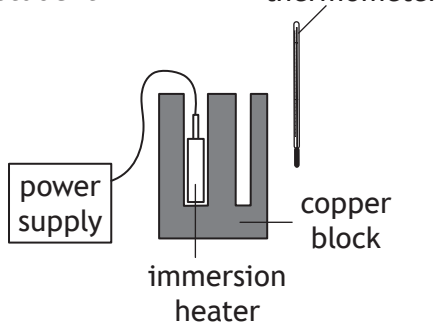

Student 5

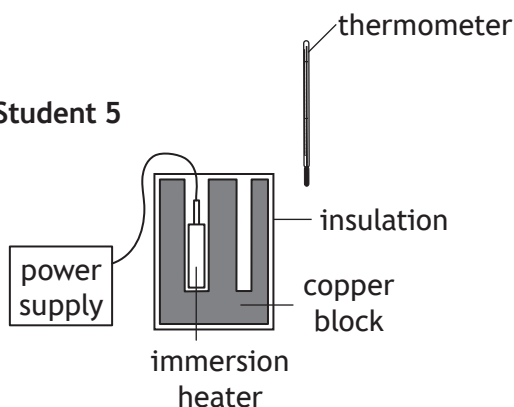

The student with the setup that would allow the most accurate value for the specific heat capacity of copper to be determined is

- A student 1
- B student 2
- C student 3
- D student 4
- E student 5.

[Turn over

6. The mass of a spacecraft is 1200 kg.

The spacecraft lands on the surface of a planet.

The gravitational field strength on the surface of the planet is  $5.0 \text{ N kg}^{-1}$ .

The spacecraft rests on three pads. The total area of the three pads is  $1.5 \text{ m}^2$ .

The pressure exerted by these pads on the surface of the planet is

- A  $1.2 \times 10^4 \text{ Pa}$
  - B  $9.0 \times 10^3 \text{ Pa}$
  - C  $7.8 \times 10^3 \text{ Pa}$
  - D  $4.0 \times 10^3 \text{ Pa}$
  - E  $8.0 \times 10^2 \text{ Pa}$ .
7. A solid is heated from  $-15^\circ\text{C}$  to  $60^\circ\text{C}$ . The temperature change of the solid is

- A 45 K
- B 75 K
- C 258 K
- D 318 K
- E 348 K.

8. A student makes the following statements about waves.

- I In a transverse wave, the particles vibrate parallel to the direction of travel of the wave.
- II Light waves and water waves are both transverse waves.
- III Sound waves are longitudinal waves.

Which of these statements is/are correct?

- A I only
- B II only
- C III only
- D I and II only
- E II and III only

9. The diagram represents a wave travelling from X to Y.

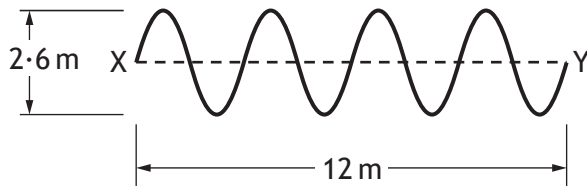

The wave travels from X to Y in a time of 0.5 s.

Which row in the table shows the amplitude, wavelength and frequency of this wave?

	<i>Amplitude (m)</i>	<i>Wavelength (m)</i>	<i>Frequency (Hz)</i>
A	1.3	1.5	2.0
B	2.6	1.5	24
C	1.3	3.0	8.0
D	2.6	3.0	8.0
E	1.3	3.0	24

10. A microwave signal is transmitted by a radar station.

The signal is reflected from an aeroplane.

The aeroplane is at a height of 30 km directly above the radar station.

The time between the signal being transmitted and the reflected signal being received back at the radar station is

- A  $5 \times 10^{-5} \text{ s}$
- B  $1 \times 10^{-4} \text{ s}$
- C  $2 \times 10^{-4} \text{ s}$
- D  $5 \times 10^3 \text{ s}$
- E  $1 \times 10^4 \text{ s}$ .

[Turn over

11. A member of the electromagnetic spectrum has a shorter wavelength than visible light and a lower frequency than X-rays. This type of radiation is
- A gamma
  - B ultraviolet
  - C infrared
  - D microwaves
  - E radio waves.
12. The diagram shows the path of a ray of red light as it passes from air into a glass block.

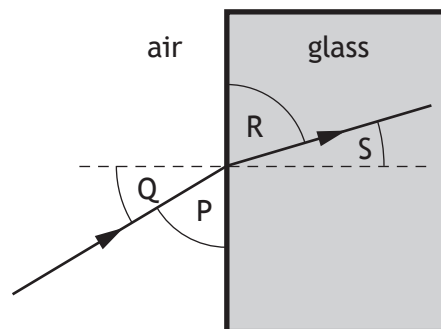

Which row in the table shows the angle of incidence and the angle of refraction?

	<i>Angle of incidence</i>	<i>Angle of refraction</i>
A	Q	S
B	S	Q
C	P	R
D	R	P
E	Q	R

13. A sample of tissue is exposed to  $15 \mu\text{Gy}$  of alpha radiation and  $20 \mu\text{Gy}$  of gamma radiation.  
The total equivalent dose received by the tissue is

- A  $35 \mu\text{Sv}$
- B  $320 \mu\text{Sv}$
- C  $415 \mu\text{Sv}$
- D  $700 \mu\text{Sv}$
- E  $735 \mu\text{Sv}$ .

14. Two forces act on an object as shown.

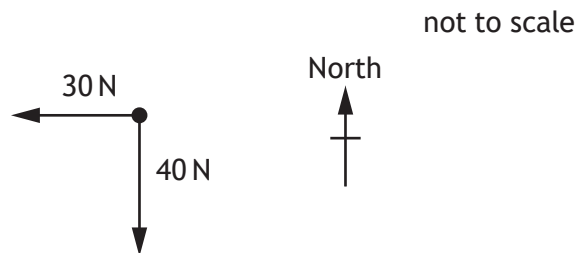

The resultant force acting on the object is

- A 50 N at a bearing of 053
- B 50 N at a bearing of 143
- C 50 N at a bearing of 217
- D 50 N at a bearing of 233
- E 50 N at a bearing of 323.

[Turn over

15. The graph shows how the velocity  $v$  of an object varies with time  $t$ .

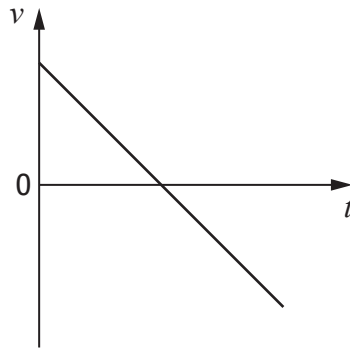

The graph could represent the motion of

- A a ball falling freely downwards
- B a rocket accelerating upwards
- C a ball thrown into the air then falling back to Earth
- D a ball falling to Earth from rest then rebounding upwards again
- E a car slowing to a halt then accelerating in the same direction.

16. A trolley is released from rest at point X and moves with constant acceleration on a slope as shown.

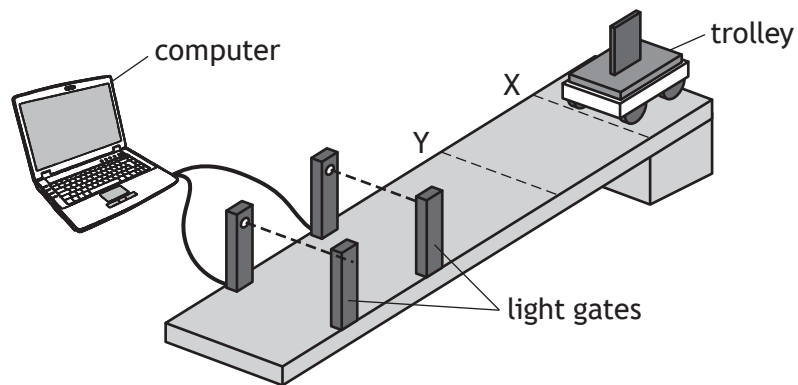

The computer displays the acceleration and average velocity of the trolley between the light gates.

The trolley is now released from rest at point Y.

Which row in the table shows how the acceleration and average velocity compare with the previous results obtained?

	<i>Acceleration</i>	<i>Average velocity</i>
A	less	same
B	same	same
C	greater	greater
D	less	less
E	same	less

[Turn over

17. A rocket accelerates vertically upwards from the surface of the Earth.

An identical rocket accelerates vertically upwards from the surface of Mars.

The engine thrust from each rocket is the same.

Which row in the table shows how the weight of the rocket and the unbalanced force acting on the rocket compares on Mars and Earth?

	<i>Weight on Mars compared to weight on Earth</i>	<i>Unbalanced force on Mars compared to unbalanced force on Earth</i>
A	greater	greater
B	same	same
C	same	less
D	less	greater
E	less	less

18. A satellite is in a circular orbit around a planet.

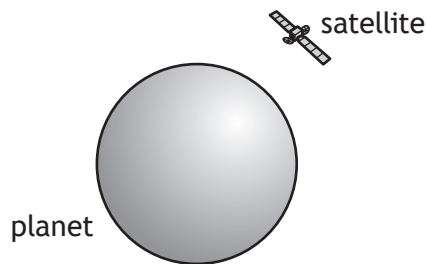

A group of students make the following statements about the satellite.

- I The greater the altitude of a satellite the shorter its orbital period.
- II The satellite has a constant vertical acceleration.
- III As the satellite orbits the planet, its vertical velocity increases.

Which of these statements is/are correct?

- A I only
  - B II only
  - C III only
  - D I and II only
  - E II and III only
19. A heater transfers energy to boiling water at the rate of 1130 joules every second.  
The maximum mass of water converted to steam in 2 minutes is
- A  $1.0 \times 10^{-3}$  kg
  - B  $6.0 \times 10^{-2}$  kg
  - C 0.41 kg
  - D 17 kg
  - E 32 kg.

[Turn over for next question

20. Light from stars can be split into line spectra of different colours.

The line spectra from three stars, X, Y and Z, are shown, along with the line spectra of the elements helium and hydrogen.

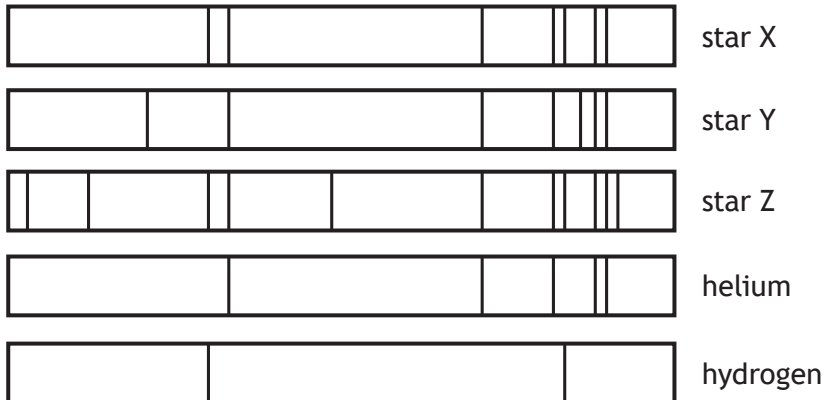

Hydrogen and helium are both present in

- A star X only
- B star Y only
- C stars X and Y only
- D stars X and Z only
- E stars X, Y and Z.

[END OF SECTION 1. NOW ATTEMPT THE QUESTIONS IN SECTION 2 OF  
YOUR QUESTION AND ANSWER BOOKLET]

[BLANK PAGE]

DO NOT WRITE ON THIS PAGE

[BLANK PAGE]

DO NOT WRITE ON THIS PAGE

FOR OFFICIAL USE



National  
Qualifications  
2017

Mark

**X757/75/01**

**Physics  
Section 1 — Answer Grid  
And Section 2**

WEDNESDAY, 17 MAY

1:00 PM – 3:00 PM



\* X 7 5 7 7 5 0 1 \*

Fill in these boxes and read what is printed below.

Full name of centre

Town

Forename(s)

Surname

Number of seat

Date of birth

Day

Month

Year

Scottish candidate number

**Total marks — 110**

**SECTION 1 — 20 marks**

Attempt ALL questions.

Instructions for completion of Section 1 are given on *Page 02*.

**SECTION 2 — 90 marks**

Attempt ALL questions.

Reference may be made to the Data Sheet on *Page 02* of the question paper X757/75/02 and to the Relationship Sheet X757/75/11.

Write your answers clearly in the spaces provided in this booklet. Additional space for answers and rough work is provided at the end of this booklet. If you use this space you must clearly identify the question number you are attempting. Any rough work must be written in this booklet. You should score through your rough work when you have written your final copy.

Use **blue** or **black** ink.

Before leaving the examination room you must give this booklet to the Invigilator; if you do not, you may lose all the marks for this paper.



\* X 7 5 7 7 5 0 1 0 1 \*

The questions for Section 1 are contained in the question paper X757/75/02.

Read these and record your answers on the answer grid on *Page 03* opposite.

Use **blue** or **black** ink. Do NOT use gel pens or pencil.

1. The answer to each question is **either** A, B, C, D or E. Decide what your answer is, then fill in the appropriate bubble (see sample question below).
2. There is **only one correct** answer to each question.
3. Any rough work must be written in the additional space for answers and rough work at the end of this booklet.

### Sample Question

The energy unit measured by the electricity meter in your home is the:

- A ampere
- B kilowatt-hour
- C watt
- D coulomb
- E volt.

The correct answer is **B** — kilowatt-hour. The answer **B** bubble has been clearly filled in (see below).

<b>A</b>	<b>B</b>	<b>C</b>	<b>D</b>	<b>E</b>
<input type="radio"/>	<input checked="" type="radio"/>	<input type="radio"/>	<input type="radio"/>	<input type="radio"/>

### Changing an answer

If you decide to change your answer, cancel your first answer by putting a cross through it (see below) and fill in the answer you want. The answer below has been changed to **D**.

<b>A</b>	<b>B</b>	<b>C</b>	<b>D</b>	<b>E</b>
<input type="radio"/>	<input checked="" type="radio"/>	<input type="radio"/>	<input checked="" type="radio"/>	<input type="radio"/>

If you then decide to change back to an answer you have already scored out, put a tick (✓) to the **right** of the answer you want, as shown below:

<b>A</b>	<b>B</b>	<b>C</b>	<b>D</b>	<b>E</b>	or	<b>A</b>	<b>B</b>	<b>C</b>	<b>D</b>	<b>E</b>
<input type="radio"/>	<input checked="" type="radio"/>	<input type="radio"/>	<input checked="" type="radio"/>	<input type="radio"/>		<input type="radio"/>	<input checked="" type="radio"/>	<input type="radio"/>	<input type="radio"/>	<input type="radio"/>



## SECTION 1 — Answer Grid



\* 0 B J 2 0 A E 1 \*

	A	B	C	D	E
1	<input type="radio"/>	<input type="radio"/>	<input type="radio"/>	<input type="radio"/>	<input type="radio"/>
2	<input type="radio"/>	<input type="radio"/>	<input type="radio"/>	<input type="radio"/>	<input type="radio"/>
3	<input type="radio"/>	<input type="radio"/>	<input type="radio"/>	<input type="radio"/>	<input type="radio"/>
4	<input type="radio"/>	<input type="radio"/>	<input type="radio"/>	<input type="radio"/>	<input type="radio"/>
5	<input type="radio"/>	<input type="radio"/>	<input type="radio"/>	<input type="radio"/>	<input type="radio"/>
6	<input type="radio"/>	<input type="radio"/>	<input type="radio"/>	<input type="radio"/>	<input type="radio"/>
7	<input type="radio"/>	<input type="radio"/>	<input type="radio"/>	<input type="radio"/>	<input type="radio"/>
8	<input type="radio"/>	<input type="radio"/>	<input type="radio"/>	<input type="radio"/>	<input type="radio"/>
9	<input type="radio"/>	<input type="radio"/>	<input type="radio"/>	<input type="radio"/>	<input type="radio"/>
10	<input type="radio"/>	<input type="radio"/>	<input type="radio"/>	<input type="radio"/>	<input type="radio"/>
11	<input type="radio"/>	<input type="radio"/>	<input type="radio"/>	<input type="radio"/>	<input type="radio"/>
12	<input type="radio"/>	<input type="radio"/>	<input type="radio"/>	<input type="radio"/>	<input type="radio"/>
13	<input type="radio"/>	<input type="radio"/>	<input type="radio"/>	<input type="radio"/>	<input type="radio"/>
14	<input type="radio"/>	<input type="radio"/>	<input type="radio"/>	<input type="radio"/>	<input type="radio"/>
15	<input type="radio"/>	<input type="radio"/>	<input type="radio"/>	<input type="radio"/>	<input type="radio"/>
16	<input type="radio"/>	<input type="radio"/>	<input type="radio"/>	<input type="radio"/>	<input type="radio"/>
17	<input type="radio"/>	<input type="radio"/>	<input type="radio"/>	<input type="radio"/>	<input type="radio"/>
18	<input type="radio"/>	<input type="radio"/>	<input type="radio"/>	<input type="radio"/>	<input type="radio"/>
19	<input type="radio"/>	<input type="radio"/>	<input type="radio"/>	<input type="radio"/>	<input type="radio"/>
20	<input type="radio"/>	<input type="radio"/>	<input type="radio"/>	<input type="radio"/>	<input type="radio"/>



\* X 7 5 7 7 5 0 1 0 3 \*

[BLANK PAGE]

DO NOT WRITE ON THIS PAGE



\* X 7 5 7 7 5 0 1 0 4 \*

[Turn over for next question

DO NOT WRITE ON THIS PAGE



\* X 7 5 7 7 5 0 1 0 5 \*

SECTION 2 — 90 marks

Attempt ALL questions

1. The rating plate on a food blender is shown.

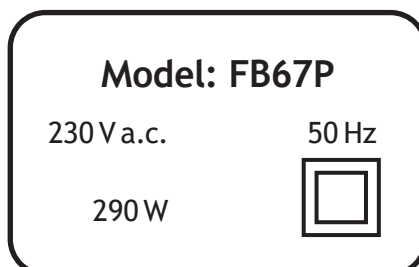

- (a) The plugs on all modern electrical appliances in the UK are fitted with fuses rated at either 3 A or 13 A.

(i) Draw the circuit symbol for a fuse.

1

(ii) State the purpose of the fuse fitted in the plug of an appliance.

1

(iii) Determine the rating of the fuse fitted in the plug of the blender.

Justify your answer by calculation.

4

*Space for working and answer*



\* X 7 5 7 7 5 0 1 0 6 \*

MARKS

DO NOT  
WRITE IN  
THIS  
MARGIN

1. (continued)

(b) The blender is connected to an alternating current (a.c.) supply.

Explain in terms of electron flow what is meant by *alternating current*.

1



\* X 7 5 7 7 5 0 1 0 7 \*

2. A student sets up the following circuit.

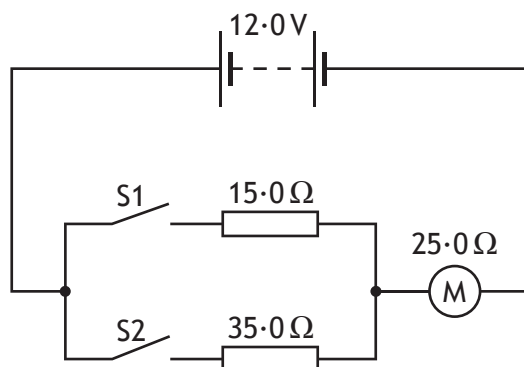

(a) The student closes switch S1.

(i) Calculate the voltage across the motor.

4

*Space for working and answer*

(ii) Calculate the power dissipated in the motor.

3

*Space for working and answer*



\* X 7 5 7 7 5 0 1 0 8 \*

MARKS

DO NOT  
WRITE IN  
THIS  
MARGIN

2. (continued)

(b) The student now also closes switch S2.

(i) Calculate the combined resistance of the two resistors.

3

*Space for working and answer*

(ii) State the effect that closing switch S2 has on the power dissipated in the motor.

3

Justify your answer.



\* X 7 5 7 7 5 0 1 0 9 \*

3. A bicycle pump with a sealed outlet contains  $4.0 \times 10^{-4} \text{ m}^3$  of air. The air inside the pump is at an initial pressure of  $1.0 \times 10^5 \text{ Pa}$ . The piston of the pump is now pushed slowly inwards until the volume of air in the pump is  $1.6 \times 10^{-4} \text{ m}^3$  as shown.

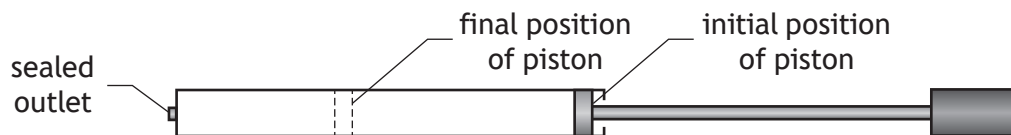

During this time the temperature of the air in the pump remains constant.

- (a) Calculate the final pressure of the air inside the pump.

3

*Space for working and answer*

- (b) Using the kinetic model, explain what happens to the pressure of the air inside the pump as its volume decreases.

3



\* X 7 5 7 7 5 0 1 1 0 \*

3. (continued)

- (c) The piston is now released, allowing it to move outwards towards its original position.

During this time the temperature of the air in the pump remains constant.

Using the axes provided, sketch a graph to show how the pressure of the air in the pump varies as its volume increases.

Numerical values are not required on either axis.

(An additional diagram, if required, can be found on *Page 28*)

2



4. A student observes water waves entering a harbour.

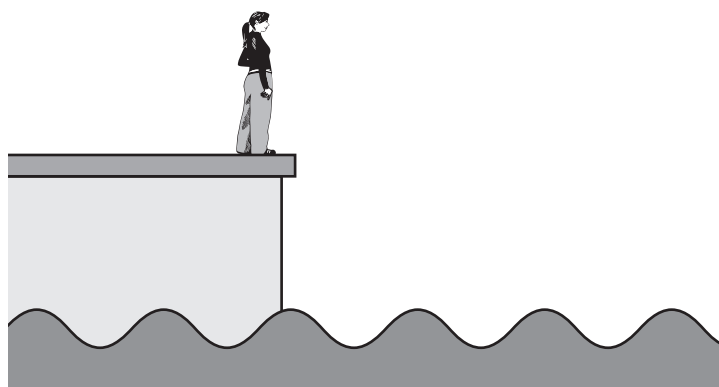

(a) To determine the frequency of the waves, the student measures the time taken for a wave to pass a point at the harbour entrance.

The student measures this time to be 2.5 s

(i) Calculate the frequency of the waves.

3

*Space for working and answer*

(ii) Suggest how the accuracy of the frequency determined by the student could be improved.

1



\* X 7 5 7 7 5 0 1 1 2 \*

4. (continued)

MARKS

DO NOT  
WRITE IN  
THIS  
MARGIN

- (b) The distance between one wave crest and the next crest is 8.0 m.  
Calculate the velocity of the waves.  
*Space for working and answer*

3

- (c) Waves travel towards the entrance of the harbour as shown.

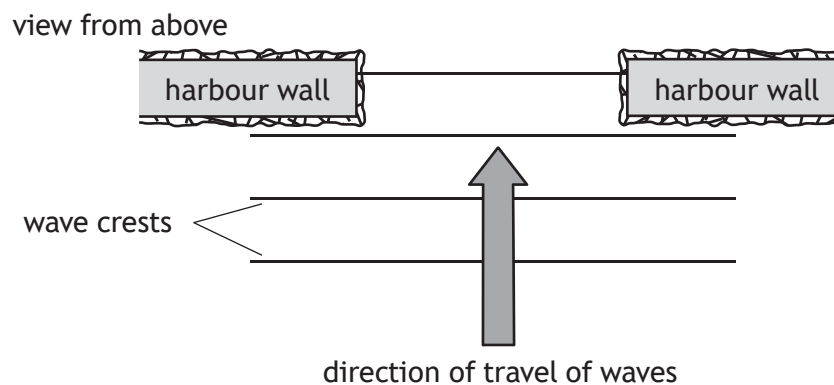

Complete the diagram to show the pattern of wave crests inside the harbour.

2

(An additional diagram, if required, can be found on *Page 28*)

- (d) As the waves pass into the harbour the student observes that the amplitude of the waves decreases.  
Explain this observation.

1



[BLANK PAGE]

DO NOT WRITE ON THIS PAGE



\* X 7 5 7 7 5 0 1 1 4 \*

MARKS

DO NOT  
WRITE IN  
THIS  
MARGIN

5. Alpha, beta and gamma are types of nuclear radiation, which have a range of properties and effects.

Using your knowledge of physics, comment on the similarities and/or differences between these types of nuclear radiation.

3



\* X 7 5 7 7 5 0 1 1 5 \*

6. A technician uses the apparatus shown to investigate the effect of shielding gamma radiation with lead.

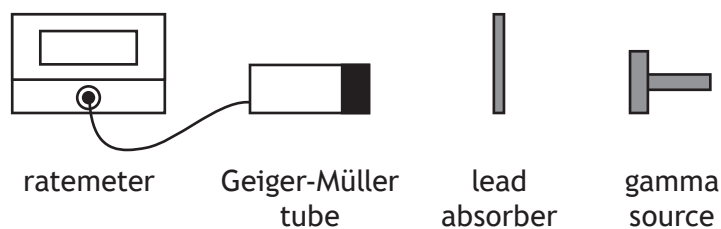

Gamma radiation passing through a lead absorber is detected by a Geiger-Müller tube. The count rate is displayed on the ratemeter.

The count rates for a range of different thicknesses of lead absorber are recorded.

Using these results the technician produces a graph of corrected count rate against thickness of lead absorber as shown.

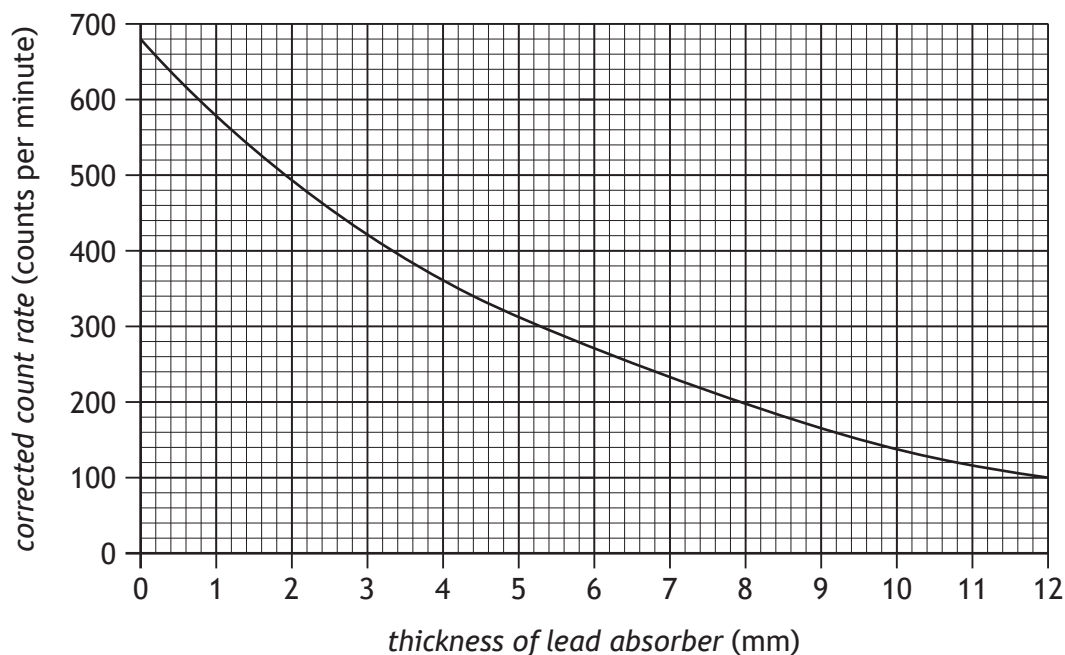

- (a) State what additional measurement the technician must have made in order to determine the corrected count rate.

1



6. (continued)

(b) The half-value thickness of a material is the thickness of material required to reduce the corrected count rate from a source by half.

(i) Using the graph, determine the half-value thickness of lead for this source of gamma radiation.

1

(ii) Determine the thickness of lead required to reduce the corrected count rate to one eighth of its initial value.

2

*Space for working and answer*

(iii) The technician suggests repeating the experiment with aluminium absorbers instead of lead absorbers.

Predict how the half-value thickness of aluminium would compare to the half-value thickness of lead for this source.

1

(c) When working with the radioactive source the technician is exposed to an equivalent dose rate of  $2.5 \times 10^{-6} \text{ Sv h}^{-1}$ .

The annual equivalent dose limit for the technician is 20 mSv.

Calculate the maximum number of hours the technician may work with this source without exceeding this limit.

3

*Space for working and answer*



\* X 7 5 7 7 5 0 1 1 7 \*

7. Nuclear reactions are used to generate electrical energy in a nuclear power station.



- (a) The fuel for the power station is in the form of pellets, containing uranium-235.

A fuel pellet has an activity of 80 kBq.

State what is meant by an *activity of 80 kBq*.

1

- (b) In a nuclear reaction a uranium-235 nucleus is split by a neutron to produce two smaller nuclei, three neutrons, and energy.

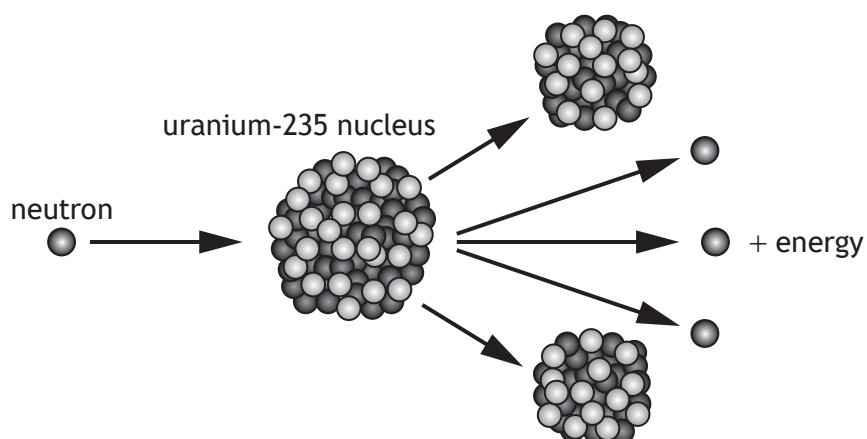

7. (b) (continued)

(i) Explain how a single reaction can lead to the continuous generation of energy.

2

(ii) One nuclear reaction releases  $3.2 \times 10^{-11}$  J.

In the reactor,  $3.0 \times 10^{21}$  reactions occur each minute.

Determine the maximum power output of the reactor.

*Space for working and answer*

4

(c) The nuclear reactor produces waste that emits nuclear radiation.

State a use of nuclear radiation.

1



\* X 7 5 7 7 5 0 1 1 9 \*

8. In speedway, motorbikes are raced anticlockwise round an oval track.



A race consists of four laps of a 380 m track.

(a) State the displacement of a motorbike from the start line to the finish line for a complete race.

1

(b) The speed-time graph of a motorbike for the first 8.0s of a race is shown.

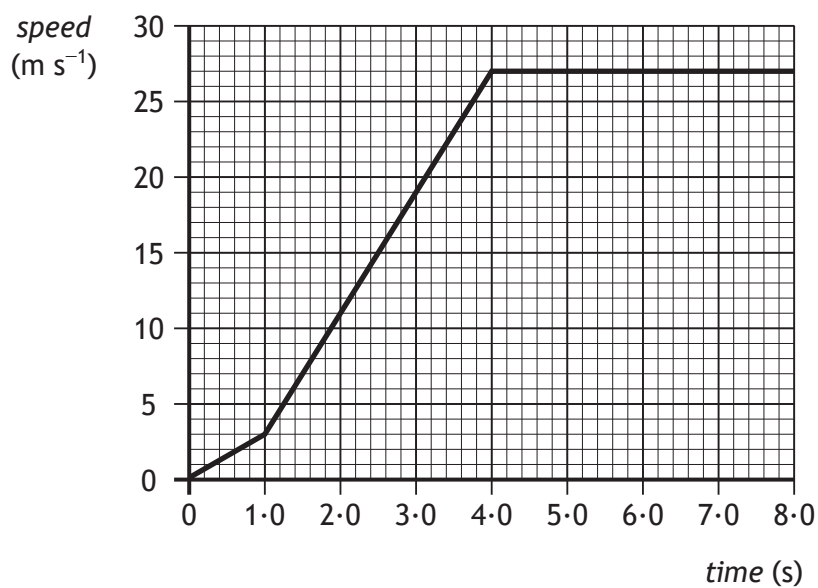

8. (b) (continued)

- (i) Calculate the distance travelled by the motorbike in the first 4.0 s of the race.

3

*Space for working and answer*

- (ii) Determine the **greatest** acceleration of the motorbike during the first 8.0 s of the race.

3

*Space for working and answer*

- (c) The winner of the race completes all four laps in a time of 79 s. Calculate the average speed of the winner.

3

*Space for working and answer*



\* X 7 5 7 7 5 0 1 2 1 \*

9. A weightlifter applies an upwards force of 1176 N to a barbell to hold it in a stationary position as shown.



- (a) Describe how the upward force exerted by the weightlifter on the barbell compares to the weight of the barbell. 1
- (b) Calculate the mass of the barbell. 3  
*Space for working and answer*
- (c) The weightlifter increases the upward force on the barbell to 1344 N in order to lift the barbell above their head. 4  
 Calculate the initial acceleration of the barbell.  
*Space for working and answer*



10. An articulated lorry has six pairs of wheels.  
One pair of wheels can be raised off the ground.

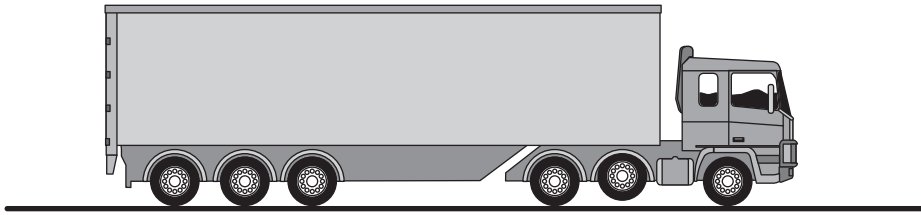

Using your knowledge of physics, comment on situations in which the wheels may be raised or lowered.

3



\* X 7 5 7 7 5 0 1 2 3 \*

11. A tennis player serves a tennis ball horizontally at a velocity of  $42 \text{ ms}^{-1}$ .

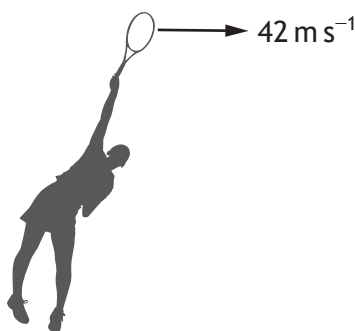

The effects of air resistance are negligible.

(a) State which of the following graphs P, Q or R shows the vertical velocity of the ball after it leaves the player's racquet.

1

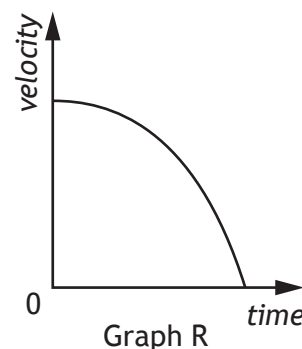
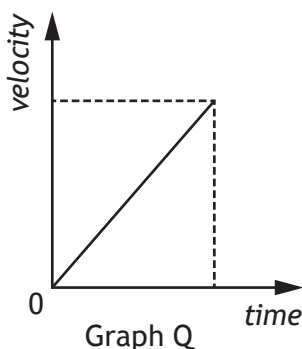
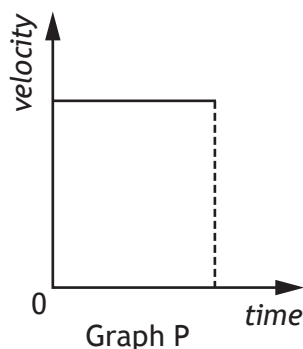

Graph: \_\_\_\_\_

(b) In a second serve the player hits the ball horizontally with a smaller velocity from the same height.

State whether the time taken for the ball to reach the ground is less than, equal to, or greater than the time taken in the first serve.

Justify your answer.

2



11. (continued)

- (c) The tennis court has a retractable roof to allow play to continue in all weather conditions.

It requires 5.5 kJ of energy to move one section of the roof a distance of 25 m.

Calculate the average force acting on this section of the roof while it is being moved.

3

*Space for working and answer*



12. The star Wolf 359 is at a distance of 7.8 light-years from Earth.  
A radio signal from Wolf 359 is detected by a radio telescope on Earth.



- (a) (i) State the speed of the radio waves. 1
- (ii) Calculate the distance, in metres, from Wolf 359 to Earth. 3  
*Space for working and answer*
- (b) Another telescope is used to observe the same star in the visible part of the spectrum.
- (i) State a suitable detector of visible light that may be used in this telescope. 1
- (ii) State whether the time taken for the visible light from the star to reach Earth is less than, equal to, or greater than the time taken for the radio waves from the star to reach Earth. 1

[END OF QUESTION PAPER]



\* X 7 5 7 7 5 0 1 2 6 \*

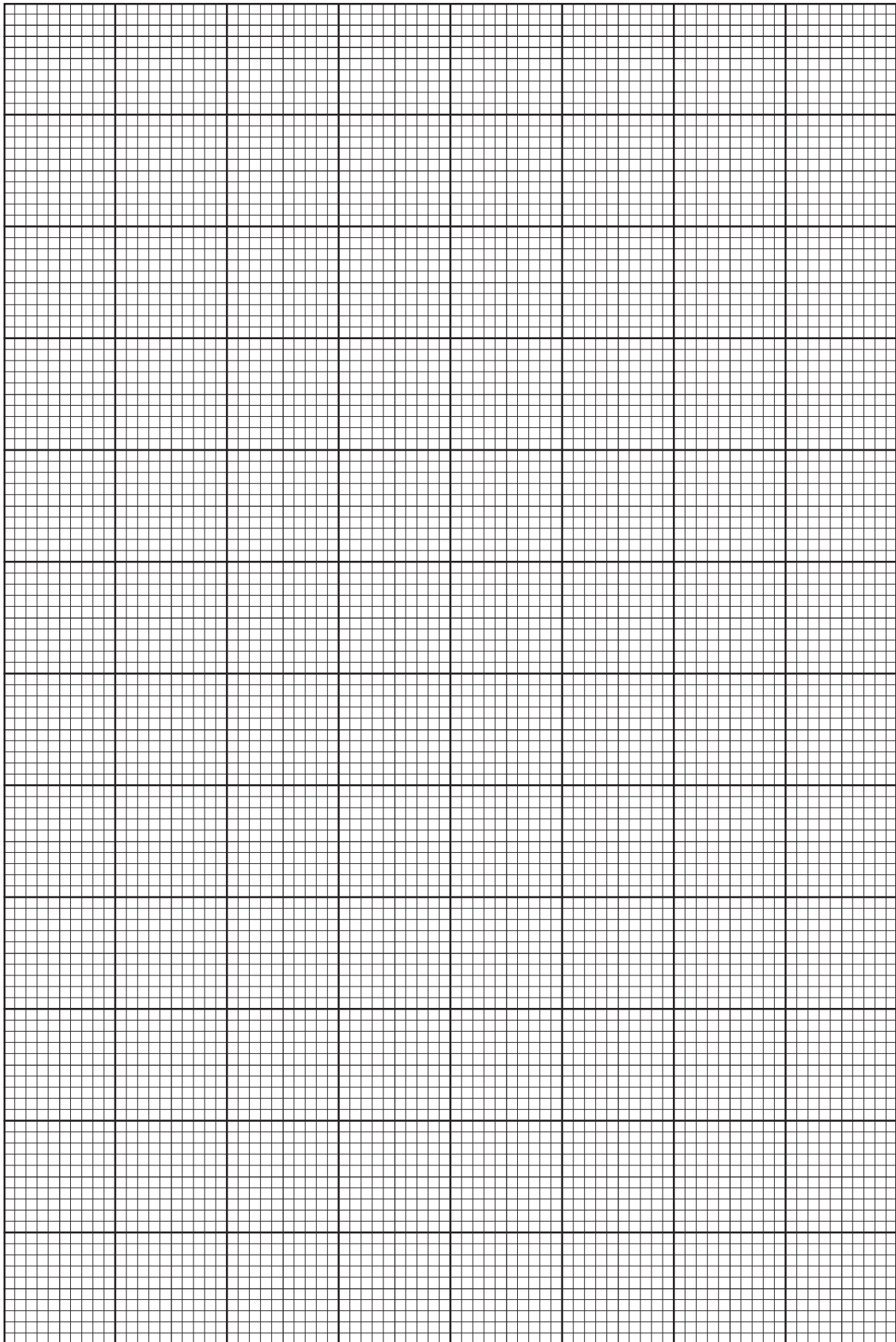

\* X 7 5 7 7 5 0 1 2 7 \*

ADDITIONAL SPACE FOR ANSWERS AND ROUGH WORKING

Additional diagram for Q3 (c)



Additional diagram for Q4 (c)

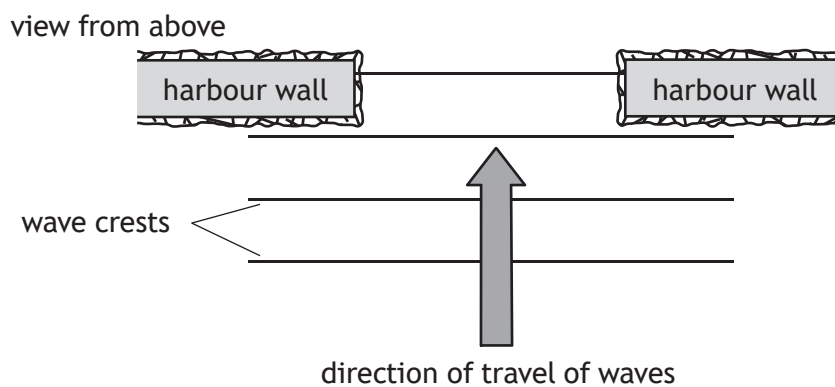

\* X 7 5 7 7 5 0 1 2 8 \*

MARKS

DO NOT  
WRITE IN  
THIS  
MARGIN

ADDITIONAL SPACE FOR ANSWERS AND ROUGH WORKING



\* X 7 5 7 7 5 0 1 2 9 \*



MARKS

DO NOT  
WRITE IN  
THIS  
MARGIN

ADDITIONAL SPACE FOR ANSWERS AND ROUGH WORKING

--



\* X 7 5 7 7 5 0 1 3 0 \*

[BLANK PAGE]

DO NOT WRITE ON THIS PAGE



\* X 7 5 7 7 5 0 1 3 1 \*

[BLANK PAGE]

DO NOT WRITE ON THIS PAGE

*Acknowledgement of Copyright*

Question 7 Michael Schneidmiller/shutterstock.com

Question 9 Ljupco Smokovski/shutterstock.com

Question 12 kojihirano/shutterstock.com



\* X 7 5 7 7 5 0 1 3 2 \*