



National  
Qualifications  
2017

**X757/75/02**

**Physics**  
**Section 1 — Questions**

WEDNESDAY, 17 MAY

1:00 PM – 3:00 PM

---

Instructions for the completion of Section 1 are given on *Page 02* of your question and answer booklet X757/75/01.

Record your answers on the answer grid on *Page 03* of your question and answer booklet.

Reference may be made to the Data Sheet on *Page 02* of this booklet and to the Relationship Sheet X757/75/11.

Before leaving the examination room you must give your question and answer booklet to the Invigilator; if you do not, you may lose all the marks for this paper.



\* X 7 5 7 7 5 0 2 \*

## DATA SHEET

### Speed of light in materials

Material	Speed in $\text{m s}^{-1}$
Air	$3.0 \times 10^8$
Carbon dioxide	$3.0 \times 10^8$
Diamond	$1.2 \times 10^8$
Glass	$2.0 \times 10^8$
Glycerol	$2.1 \times 10^8$
Water	$2.3 \times 10^8$

### Speed of sound in materials

Material	Speed in $\text{m s}^{-1}$
Aluminium	5200
Air	340
Bone	4100
Carbon dioxide	270
Glycerol	1900
Muscle	1600
Steel	5200
Tissue	1500
Water	1500

### Gravitational field strengths

	Gravitational field strength on the surface in $\text{N kg}^{-1}$
Earth	9.8
Jupiter	23
Mars	3.7
Mercury	3.7
Moon	1.6
Neptune	11
Saturn	9.0
Sun	270
Uranus	8.7
Venus	8.9

### Specific heat capacity of materials

Material	Specific heat capacity in $\text{J kg}^{-1} \text{ } ^\circ\text{C}^{-1}$
Alcohol	2350
Aluminium	902
Copper	386
Glass	500
Ice	2100
Iron	480
Lead	128
Oil	2130
Water	4180

### Specific latent heat of fusion of materials

Material	Specific latent heat of fusion in $\text{J kg}^{-1}$
Alcohol	$0.99 \times 10^5$
Aluminium	$3.95 \times 10^5$
Carbon Dioxide	$1.80 \times 10^5$
Copper	$2.05 \times 10^5$
Iron	$2.67 \times 10^5$
Lead	$0.25 \times 10^5$
Water	$3.34 \times 10^5$

### Melting and boiling points of materials

Material	Melting point in $^\circ\text{C}$	Boiling point in $^\circ\text{C}$
Alcohol	-98	65
Aluminium	660	2470
Copper	1077	2567
Glycerol	18	290
Lead	328	1737
Iron	1537	2737

### Specific latent heat of vaporisation of materials

Material	Specific latent heat of vaporisation in $\text{J kg}^{-1}$
Alcohol	$11.2 \times 10^5$
Carbon Dioxide	$3.77 \times 10^5$
Glycerol	$8.30 \times 10^5$
Turpentine	$2.90 \times 10^5$
Water	$22.6 \times 10^5$

### Radiation weighting factors

Type of radiation	Radiation weighting factor
alpha	20
beta	1
fast neutrons	10
gamma	1
slow neutrons	3
X-rays	1

SECTION 1

Attempt ALL questions

1. A cyclist is travelling along a straight road. The graph shows how the velocity of the cyclist varies with time.

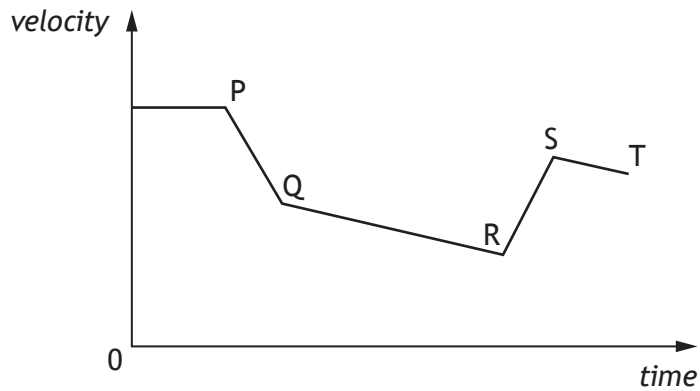

The kinetic energy of the cyclist is greatest at

- A P
  - B Q
  - C R
  - D S
  - E T.
2. A circuit is set up as shown.

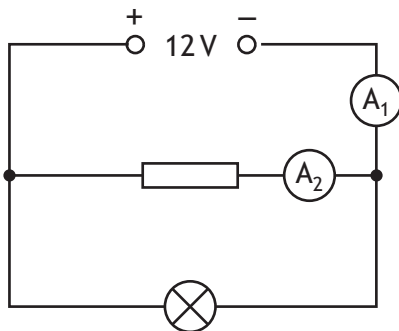

The reading on ammeter  $A_1$  is 5.0 A. The reading on ammeter  $A_2$  is 2.0 A.

The charge passing through the lamp in 30 seconds is

- A 0.1 C
- B 10 C
- C 60 C
- D 90 C
- E 150 C.

3. A lamp is connected to a constant voltage power supply. The power supply is switched on. The graph shows how the current in the lamp varies with time.

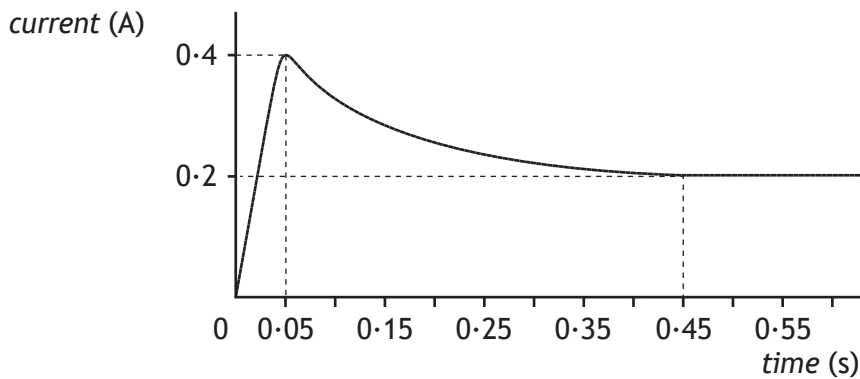

Which row in the table shows what happens to the current and resistance of the lamp between 0.05 s and 0.45 s?

	<i>Current</i>	<i>Resistance</i>
A	decreases	increases
B	decreases	stays the same
C	stays the same	decreases
D	increases	decreases
E	increases	increases

4. A circuit is set up as shown.

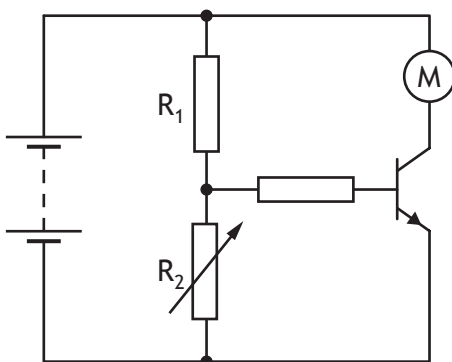

The purpose of the transistor is to

- A supply energy to the circuit
- B decrease the voltage across  $R_1$
- C change electrical energy to kinetic energy
- D supply energy to the motor
- E switch on the motor.

5. Five students each carry out an experiment to determine the specific heat capacity of copper. The setup used by each student is shown.

Student 1

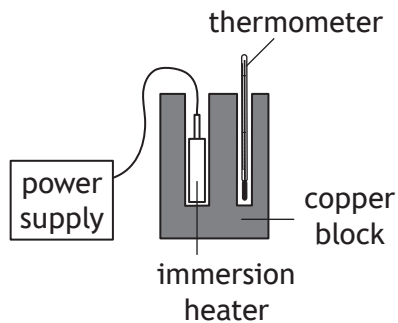

Student 2

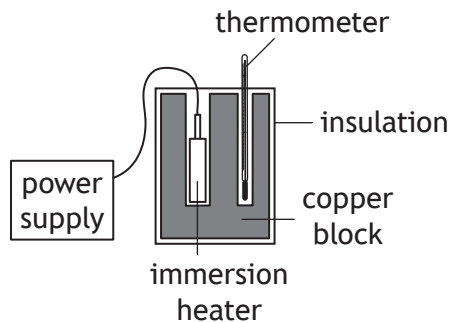

Student 3

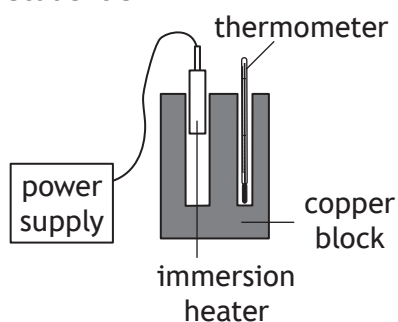

Student 4

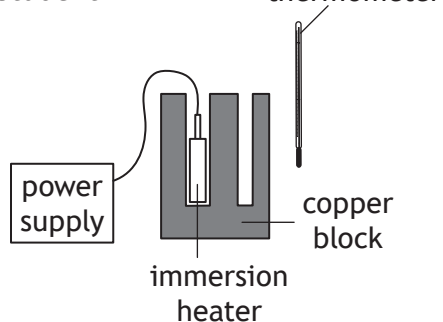

Student 5

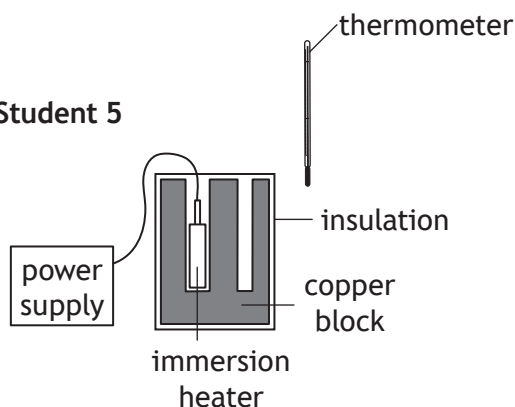

The student with the setup that would allow the most accurate value for the specific heat capacity of copper to be determined is

- A student 1
- B student 2
- C student 3
- D student 4
- E student 5.

[Turn over

6. The mass of a spacecraft is 1200 kg.

The spacecraft lands on the surface of a planet.

The gravitational field strength on the surface of the planet is  $5.0 \text{ N kg}^{-1}$ .

The spacecraft rests on three pads. The total area of the three pads is  $1.5 \text{ m}^2$ .

The pressure exerted by these pads on the surface of the planet is

- A  $1.2 \times 10^4 \text{ Pa}$
  - B  $9.0 \times 10^3 \text{ Pa}$
  - C  $7.8 \times 10^3 \text{ Pa}$
  - D  $4.0 \times 10^3 \text{ Pa}$
  - E  $8.0 \times 10^2 \text{ Pa}$ .
7. A solid is heated from  $-15^\circ\text{C}$  to  $60^\circ\text{C}$ . The temperature change of the solid is

- A 45 K
- B 75 K
- C 258 K
- D 318 K
- E 348 K.

8. A student makes the following statements about waves.

- I In a transverse wave, the particles vibrate parallel to the direction of travel of the wave.
- II Light waves and water waves are both transverse waves.
- III Sound waves are longitudinal waves.

Which of these statements is/are correct?

- A I only
- B II only
- C III only
- D I and II only
- E II and III only

9. The diagram represents a wave travelling from X to Y.

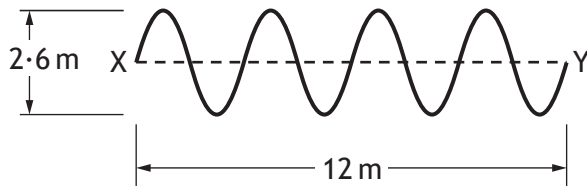

The wave travels from X to Y in a time of 0.5 s.

Which row in the table shows the amplitude, wavelength and frequency of this wave?

	<i>Amplitude (m)</i>	<i>Wavelength (m)</i>	<i>Frequency (Hz)</i>
A	1.3	1.5	2.0
B	2.6	1.5	24
C	1.3	3.0	8.0
D	2.6	3.0	8.0
E	1.3	3.0	24

10. A microwave signal is transmitted by a radar station.

The signal is reflected from an aeroplane.

The aeroplane is at a height of 30 km directly above the radar station.

The time between the signal being transmitted and the reflected signal being received back at the radar station is

- A  $5 \times 10^{-5} \text{ s}$
- B  $1 \times 10^{-4} \text{ s}$
- C  $2 \times 10^{-4} \text{ s}$
- D  $5 \times 10^3 \text{ s}$
- E  $1 \times 10^4 \text{ s}$ .

[Turn over

11. A member of the electromagnetic spectrum has a shorter wavelength than visible light and a lower frequency than X-rays. This type of radiation is
- A gamma
  - B ultraviolet
  - C infrared
  - D microwaves
  - E radio waves.
12. The diagram shows the path of a ray of red light as it passes from air into a glass block.

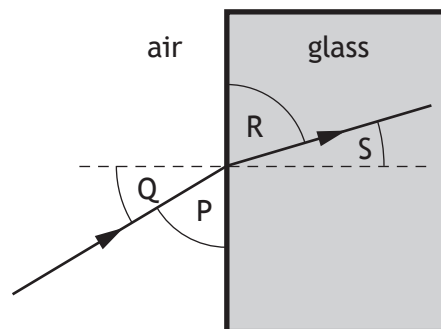

Which row in the table shows the angle of incidence and the angle of refraction?

	<i>Angle of incidence</i>	<i>Angle of refraction</i>
A	Q	S
B	S	Q
C	P	R
D	R	P
E	Q	R

13. A sample of tissue is exposed to  $15 \mu\text{Gy}$  of alpha radiation and  $20 \mu\text{Gy}$  of gamma radiation.  
The total equivalent dose received by the tissue is

- A  $35 \mu\text{Sv}$
- B  $320 \mu\text{Sv}$
- C  $415 \mu\text{Sv}$
- D  $700 \mu\text{Sv}$
- E  $735 \mu\text{Sv}$ .

14. Two forces act on an object as shown.

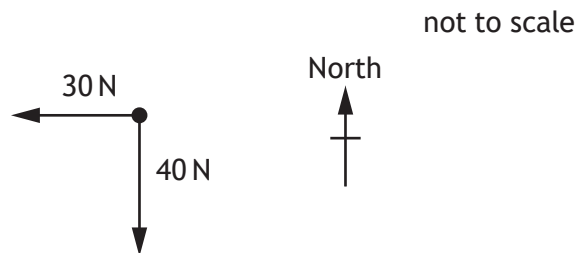

The resultant force acting on the object is

- A 50 N at a bearing of 053
- B 50 N at a bearing of 143
- C 50 N at a bearing of 217
- D 50 N at a bearing of 233
- E 50 N at a bearing of 323.

[Turn over

15. The graph shows how the velocity  $v$  of an object varies with time  $t$ .

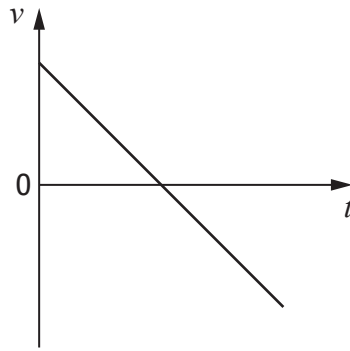

The graph could represent the motion of

- A a ball falling freely downwards
- B a rocket accelerating upwards
- C a ball thrown into the air then falling back to Earth
- D a ball falling to Earth from rest then rebounding upwards again
- E a car slowing to a halt then accelerating in the same direction.

16. A trolley is released from rest at point X and moves with constant acceleration on a slope as shown.

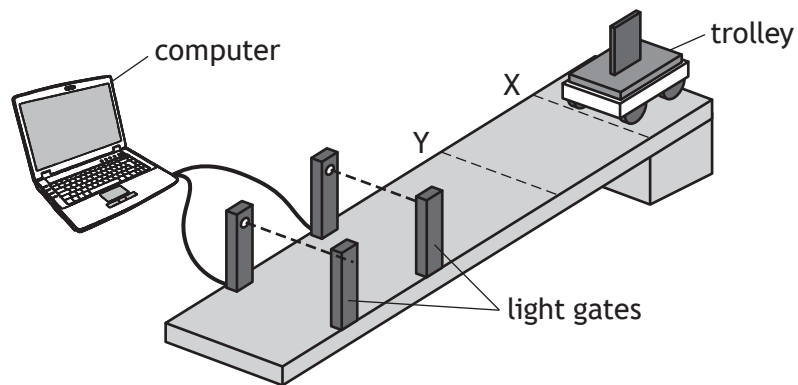

The computer displays the acceleration and average velocity of the trolley between the light gates.

The trolley is now released from rest at point Y.

Which row in the table shows how the acceleration and average velocity compare with the previous results obtained?

	<i>Acceleration</i>	<i>Average velocity</i>
A	less	same
B	same	same
C	greater	greater
D	less	less
E	same	less

[Turn over

17. A rocket accelerates vertically upwards from the surface of the Earth.

An identical rocket accelerates vertically upwards from the surface of Mars.

The engine thrust from each rocket is the same.

Which row in the table shows how the weight of the rocket and the unbalanced force acting on the rocket compares on Mars and Earth?

	<i>Weight on Mars compared to weight on Earth</i>	<i>Unbalanced force on Mars compared to unbalanced force on Earth</i>
A	greater	greater
B	same	same
C	same	less
D	less	greater
E	less	less

18. A satellite is in a circular orbit around a planet.

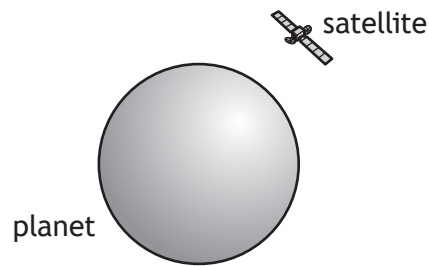

A group of students make the following statements about the satellite.

- I The greater the altitude of a satellite the shorter its orbital period.
- II The satellite has a constant vertical acceleration.
- III As the satellite orbits the planet, its vertical velocity increases.

Which of these statements is/are correct?

- A I only
  - B II only
  - C III only
  - D I and II only
  - E II and III only
19. A heater transfers energy to boiling water at the rate of 1130 joules every second.  
The maximum mass of water converted to steam in 2 minutes is
- A  $1.0 \times 10^{-3}$  kg
  - B  $6.0 \times 10^{-2}$  kg
  - C 0.41 kg
  - D 17 kg
  - E 32 kg.

[Turn over for next question

20. Light from stars can be split into line spectra of different colours.

The line spectra from three stars, X, Y and Z, are shown, along with the line spectra of the elements helium and hydrogen.

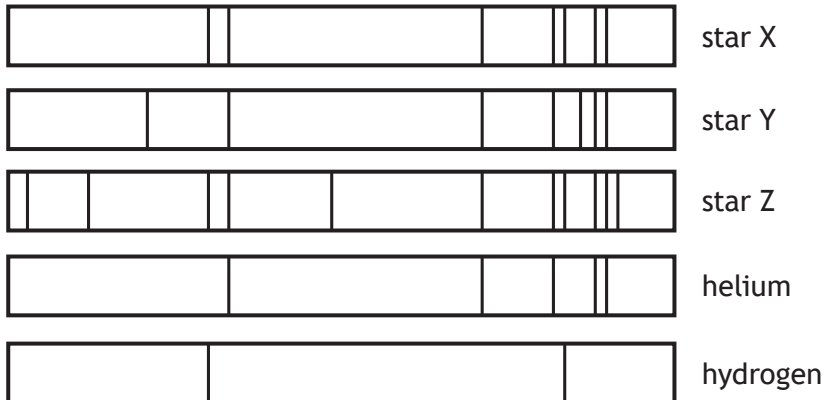

Hydrogen and helium are both present in

- A star X only
- B star Y only
- C stars X and Y only
- D stars X and Z only
- E stars X, Y and Z.

[END OF SECTION 1. NOW ATTEMPT THE QUESTIONS IN SECTION 2 OF  
YOUR QUESTION AND ANSWER BOOKLET]

[BLANK PAGE]

DO NOT WRITE ON THIS PAGE

[BLANK PAGE]

DO NOT WRITE ON THIS PAGE