

FOR OFFICIAL USE



National
Qualifications
2018

Mark

X857/75/01

**Physics
Section 1 — Answer Grid
and Section 2**

TUESDAY, 8 MAY
1:00 PM – 3:30 PM



* X 8 5 7 7 5 0 1 *

Fill in these boxes and read what is printed below.

Full name of centre

Town

Forename(s)

Surname

Number of seat

Date of birth

Day

Month

Year

Scottish candidate number

Total marks — 135

SECTION 1 — 25 marks

Attempt ALL questions.

Instructions for completion of Section 1 are given on *page 02*.

SECTION 2 — 110 marks

Attempt ALL questions.

Reference may be made to the Data Sheet on *page 02* of the question paper X857/75/02 and to the Relationships Sheet X857/75/11.

Write your answers clearly in the spaces provided in this booklet. Additional space for answers and rough work is provided at the end of this booklet. If you use this space you must clearly identify the question number you are attempting. Any rough work must be written in this booklet. Score through your rough work when you have written your final copy.

Use **blue** or **black** ink.

Before leaving the examination room you must give this booklet to the Invigilator; if you do not, you may lose all the marks for this paper.



* X 8 5 7 7 5 0 1 0 1 *

The questions for Section 1 are contained in the question paper X857/75/02.

Read these and record your answers on the answer grid on *page 03* opposite.

Use **blue** or **black** ink. Do NOT use gel pens or pencil.

1. The answer to each question is **either** A, B, C, D or E. Decide what your answer is, then fill in the appropriate bubble (see sample question below).
2. There is **only one correct** answer to each question.
3. Any rough work must be written in the additional space for answers and rough work at the end of this booklet.

Sample question

The energy unit measured by the electricity meter in your home is the

- A ampere
- B kilowatt-hour
- C watt
- D coulomb
- E volt.

The correct answer is **B** — kilowatt-hour. The answer **B** bubble has been clearly filled in (see below).

A	B	C	D	E
<input type="radio"/>	<input checked="" type="radio"/>	<input type="radio"/>	<input type="radio"/>	<input type="radio"/>

Changing an answer

If you decide to change your answer, cancel your first answer by putting a cross through it (see below) and fill in the answer you want. The answer below has been changed to **D**.

A	B	C	D	E
<input type="radio"/>	<input checked="" type="radio"/>	<input type="radio"/>	<input checked="" type="radio"/>	<input type="radio"/>

If you then decide to change back to an answer you have already scored out, put a tick (✓) to the **right** of the answer you want, as shown below:

A	B	C	D	E	or	A	B	C	D	E
<input type="radio"/>	<input checked="" type="radio"/>	<input type="radio"/>	<input checked="" type="radio"/>	<input type="radio"/>		<input type="radio"/>	<input checked="" type="radio"/>	<input type="radio"/>	<input type="radio"/>	<input type="radio"/>



SECTION 1 — Answer Grid



* O B J 2 5 A E 1 *

	A	B	C	D	E
1	<input type="radio"/>	<input type="radio"/>	<input type="radio"/>	<input type="radio"/>	<input type="radio"/>
2	<input type="radio"/>	<input type="radio"/>	<input type="radio"/>	<input type="radio"/>	<input type="radio"/>
3	<input type="radio"/>	<input type="radio"/>	<input type="radio"/>	<input type="radio"/>	<input type="radio"/>
4	<input type="radio"/>	<input type="radio"/>	<input type="radio"/>	<input type="radio"/>	<input type="radio"/>
5	<input type="radio"/>	<input type="radio"/>	<input type="radio"/>	<input type="radio"/>	<input type="radio"/>
6	<input type="radio"/>	<input type="radio"/>	<input type="radio"/>	<input type="radio"/>	<input type="radio"/>
7	<input type="radio"/>	<input type="radio"/>	<input type="radio"/>	<input type="radio"/>	<input type="radio"/>
8	<input type="radio"/>	<input type="radio"/>	<input type="radio"/>	<input type="radio"/>	<input type="radio"/>
9	<input type="radio"/>	<input type="radio"/>	<input type="radio"/>	<input type="radio"/>	<input type="radio"/>
10	<input type="radio"/>	<input type="radio"/>	<input type="radio"/>	<input type="radio"/>	<input type="radio"/>
11	<input type="radio"/>	<input type="radio"/>	<input type="radio"/>	<input type="radio"/>	<input type="radio"/>
12	<input type="radio"/>	<input type="radio"/>	<input type="radio"/>	<input type="radio"/>	<input type="radio"/>
13	<input type="radio"/>	<input type="radio"/>	<input type="radio"/>	<input type="radio"/>	<input type="radio"/>
14	<input type="radio"/>	<input type="radio"/>	<input type="radio"/>	<input type="radio"/>	<input type="radio"/>
15	<input type="radio"/>	<input type="radio"/>	<input type="radio"/>	<input type="radio"/>	<input type="radio"/>
16	<input type="radio"/>	<input type="radio"/>	<input type="radio"/>	<input type="radio"/>	<input type="radio"/>
17	<input type="radio"/>	<input type="radio"/>	<input type="radio"/>	<input type="radio"/>	<input type="radio"/>
18	<input type="radio"/>	<input type="radio"/>	<input type="radio"/>	<input type="radio"/>	<input type="radio"/>
19	<input type="radio"/>	<input type="radio"/>	<input type="radio"/>	<input type="radio"/>	<input type="radio"/>
20	<input type="radio"/>	<input type="radio"/>	<input type="radio"/>	<input type="radio"/>	<input type="radio"/>
21	<input type="radio"/>	<input type="radio"/>	<input type="radio"/>	<input type="radio"/>	<input type="radio"/>
22	<input type="radio"/>	<input type="radio"/>	<input type="radio"/>	<input type="radio"/>	<input type="radio"/>
23	<input type="radio"/>	<input type="radio"/>	<input type="radio"/>	<input type="radio"/>	<input type="radio"/>
24	<input type="radio"/>	<input type="radio"/>	<input type="radio"/>	<input type="radio"/>	<input type="radio"/>
25	<input type="radio"/>	<input type="radio"/>	<input type="radio"/>	<input type="radio"/>	<input type="radio"/>



* X 8 5 7 7 5 0 1 0 3 *

[BLANK PAGE]

DO NOT WRITE ON THIS PAGE



* X 8 5 7 7 5 0 1 0 4 *

[Turn over for SECTION 2

DO NOT WRITE ON THIS PAGE



* X 8 5 7 7 5 0 1 0 5 *

SECTION 2 — 110 marks

Attempt ALL questions

1. A passenger aircraft is flying horizontally.
- (a) At one point during the flight the aircraft engines produce an unbalanced force of 184 kN due south (180).

At this point the aircraft also experiences a crosswind. The force of the crosswind on the aircraft is 138 kN due east (090).

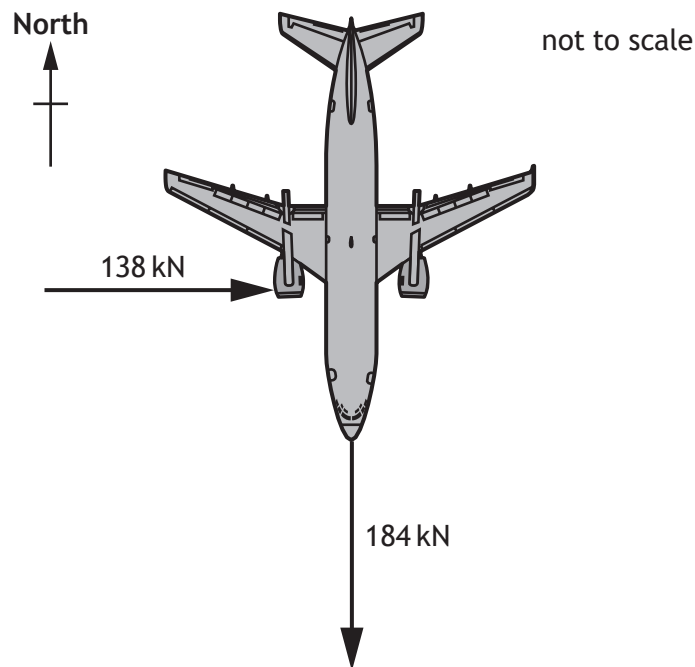

* X 8 5 7 7 5 0 1 0 6 *

1. (a) (continued)

MARKS
DO NOT
WRITE IN
THIS
MARGIN

(i) By scale diagram, or otherwise, determine:

(A) the magnitude of the resultant force acting on the aircraft;

2

Space for working and answer

(B) the direction of the resultant force acting on the aircraft.

2

Space for working and answer

[Turn over



* X 8 5 7 7 5 0 1 0 7 *

1. (a) (continued)

MARKS
DO NOT
WRITE IN
THIS
MARGIN

(ii) The mass of the aircraft is 6.8×10^4 kg.

Calculate the magnitude of the acceleration of the aircraft at this point.

3

Space for working and answer

(b) During the flight the aircraft uses fuel.

Explain why the pressure exerted by the tyres of the aircraft on the runway after the flight is less than the pressure exerted by the tyres on the runway before the flight.

2



* X 8 5 7 7 5 0 1 0 8 *

[Turn over for next question

DO NOT WRITE ON THIS PAGE



* X 8 5 7 7 5 0 1 0 9 *

2. Two students are investigating the acceleration of a trolley down a ramp.
- (a) The first student uses the apparatus shown to determine the acceleration of the trolley.

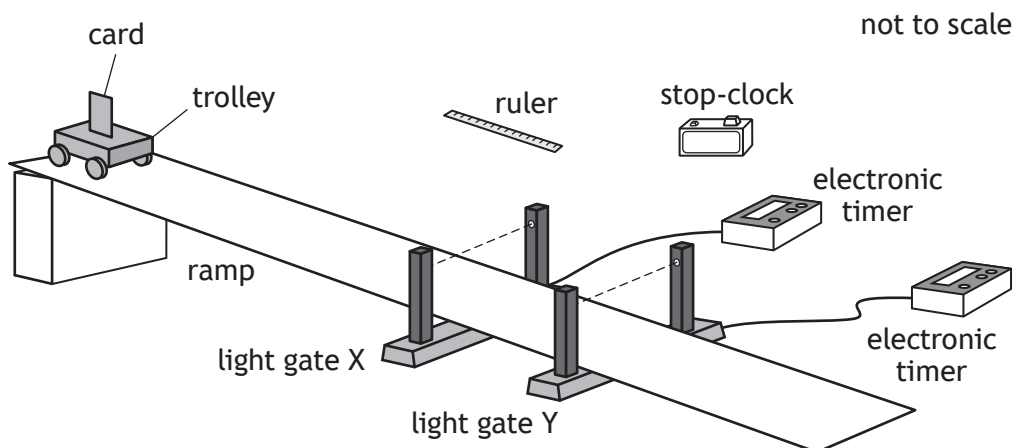

Some of the measurements made by the student are shown.

Time for the card to pass through light gate Y	0.098 s
Distance between light gate X and light gate Y	0.22 m
Length of the card	0.045 m
Time for trolley to pass between light gate X and light gate Y	0.56 s

The student determines the instantaneous speed of the trolley at light gate X to be 0.32 m s^{-1} .

- (i) State the **additional** measurement made by the student to determine the instantaneous speed of the trolley at light gate X. 1



2. (a) (continued)

MARKS

DO NOT
WRITE IN
THIS
MARGIN

- (ii) Show that the instantaneous speed of the trolley at light gate Y is 0.46 m s^{-1} .

2

Space for working and answer

- (iii) Determine the acceleration of the trolley down the ramp.

3

Space for working and answer

[Turn over



* X 8 5 7 7 5 0 1 1 1 *

2. (continued)

MARKS

DO NOT
WRITE IN
THIS
MARGIN

- (b) The second student uses a motion sensor and a computer to determine the acceleration of the trolley.

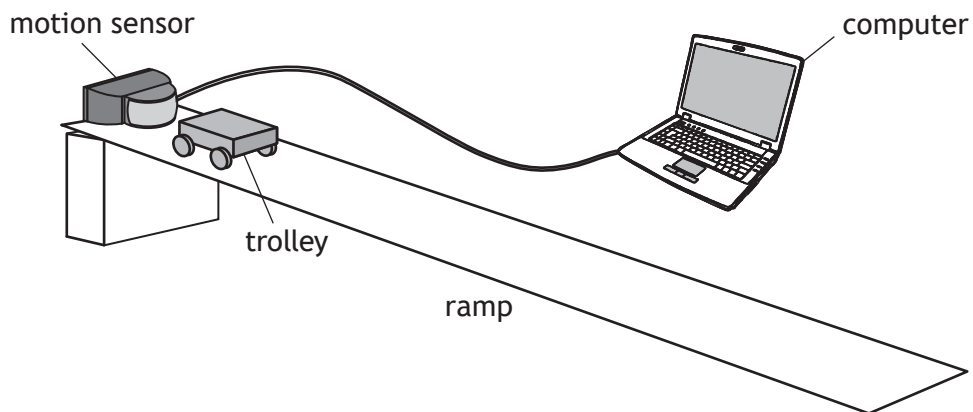

The student releases the trolley. The computer displays the velocity-time graph for the motion of the trolley as it rolls down the ramp, as shown.

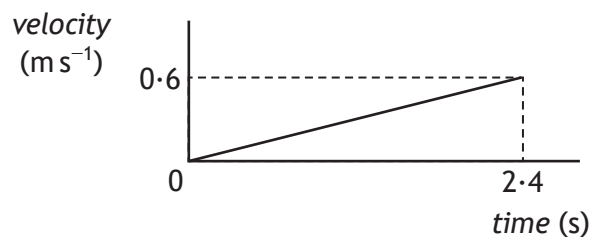

Determine the distance travelled by the trolley in the first 2.4 s after its release.

3

Space for working and answer



* X 8 5 7 7 5 0 1 1 2 *

2. (continued)

MARKS

DO NOT
WRITE IN
THIS
MARGIN

- (c) In a further experiment the second student places a piece of elastic across the bottom of the ramp as shown.

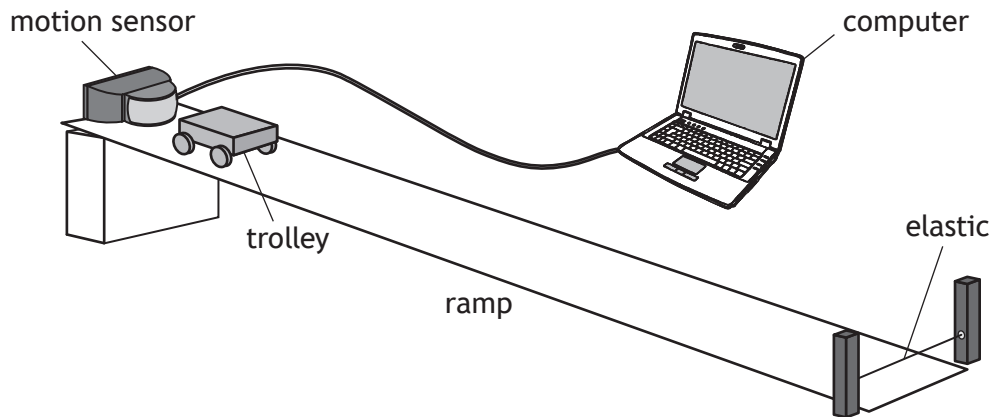

The student again releases the trolley. The trolley rolls down the ramp and rebounds from the elastic to move back up the ramp.

Using the axes provided, complete the velocity-time graph for the motion of the trolley from the moment it contacts the elastic, until it reaches its maximum height back up the ramp.

2

Numerical values are not required on either axis.

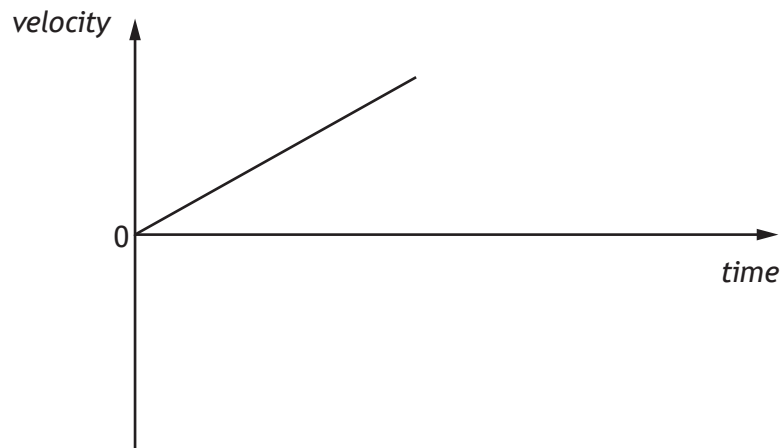

(An additional diagram, if required, can be found on page 43.)

[Turn over



3. During a BMX competition, a cyclist freewheels down a slope and up a 'kicker' to complete a vertical jump.

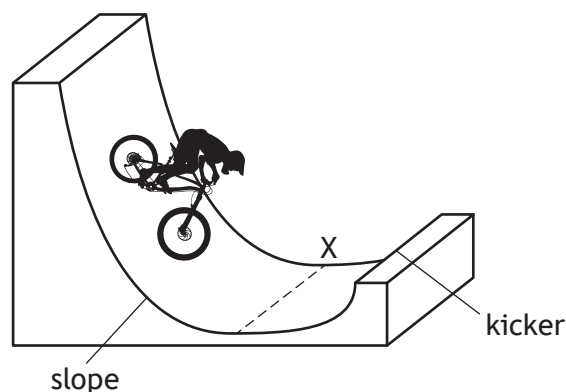

The cyclist and bike have a combined mass of 75 kg.

At point X the cyclist and bike have a speed of 8.0 m s^{-1} .

- (a) Calculate the kinetic energy of the cyclist and bike at point X. 3

Space for working and answer

- (b) (i) Calculate the maximum height of the jump above point X. 3

Space for working and answer

- (ii) Explain why the actual height of the jump above point X would be less than the height calculated in (b) (i). 1



* X 8 5 7 7 5 0 1 1 4 *

3. (continued)

MARKS
DO NOT
WRITE IN
THIS
MARGIN

- (c) During another part of the competition, the cyclist and bike travel horizontally at 6.0 m s^{-1} off a ledge as shown.

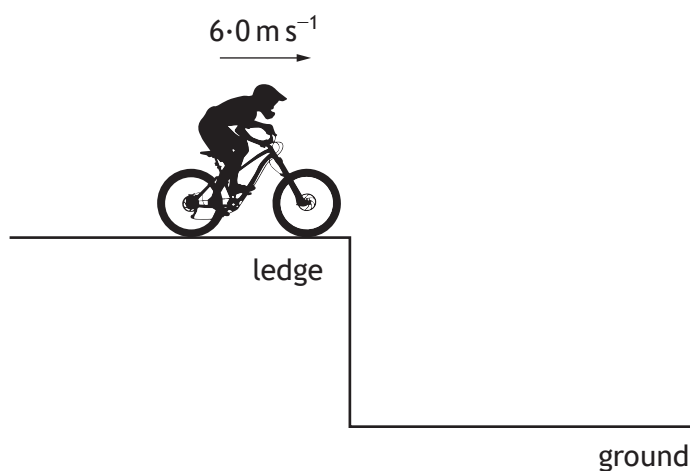

- (i) On the diagram above, sketch the path taken by the cyclist and bike between leaving the ledge and reaching the ground. 1
(An additional diagram, if required, can be found on *page 43*.)
- (ii) The cyclist and bike reach the ground 0.40 s after leaving the ledge. Calculate the vertical velocity of the cyclist and bike as they reach the ground. 3
The effects of air resistance can be ignored.
Space for working and answer

[Turn over



4. Within our solar system distances are often measured in astronomical units (AU).

$$1 \text{ AU} = 1.50 \times 10^{11} \text{ m.}$$

Mars orbits the Sun at an average distance of 1.52 AU.

(a) (i) Determine the average distance, in metres, at which Mars orbits the Sun. 1

Space for working and answer

(ii) Calculate the average time for light from the Sun to reach Mars. 3

Space for working and answer



* X 8 5 7 7 5 0 1 1 6 *

4. (continued)

MARKS
DO NOT
WRITE IN
THIS
MARGIN

(b) In the future it is hoped that humans will be able to travel to Mars. One challenge of space travel to Mars is maintaining sufficient energy to operate life support systems.

(i) Suggest one solution to this challenge.

1

(ii) State another challenge of space travel to Mars.

1

[Turn over



* X 8 5 7 7 5 0 1 1 7 *

5. A group of students are watching a video clip of astronauts on board the International Space Station (ISS) as it orbits the Earth.



One student states, 'I would love to be weightless and float like the astronauts do on the ISS.'

Using your knowledge of physics, comment on the statement made by the student.

3



6. A solar jar is designed to collect energy from the Sun during the day and release this energy as light at night.
When the solar jar is placed in sunlight, photovoltaic cells on the lid are used to charge a rechargeable battery.

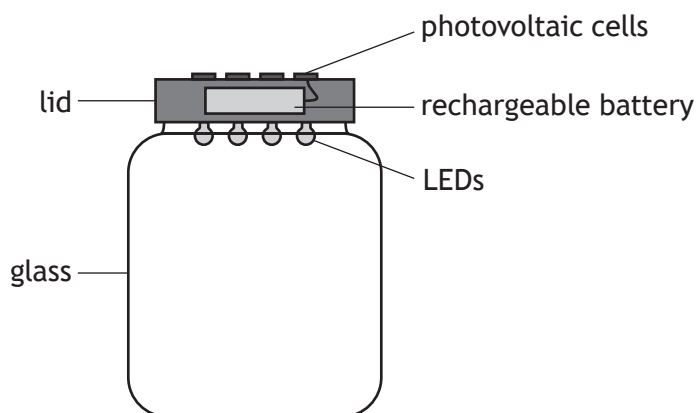

At night, the rechargeable battery is used to power four identical LEDs.

- (a) Part of the circuit in the solar jar is shown.

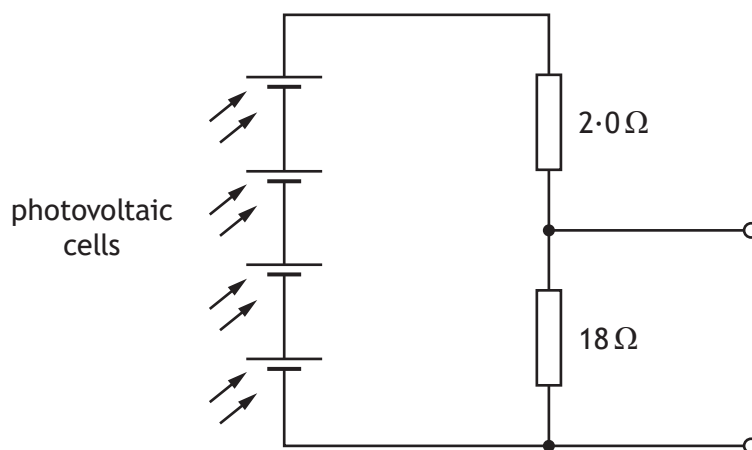

In direct sunlight the photovoltaic cells produce a combined voltage of 4.0V.

Calculate the voltage across the 18 Ω resistor.

3

Space for working and answer

[Turn over



6. (continued)

MARKS
DO NOT
WRITE IN
THIS
MARGIN

(b) Another part of the circuit containing the LEDs is shown.

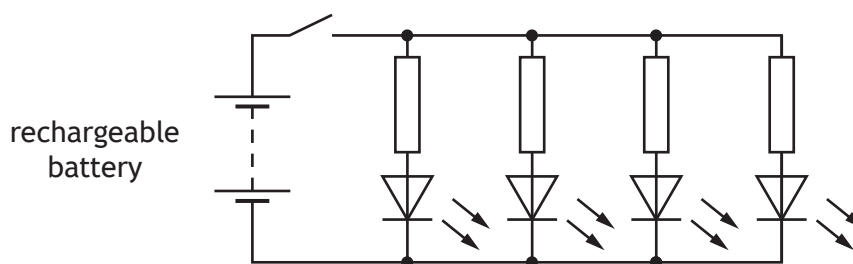

The switch is now closed and the LEDs light.

(i) State the purpose of the resistor connected in series with each LED.

1

(ii) After a few hours the rechargeable battery produces a voltage of 3.4 V.

At this point in time the voltage across each LED is 1.6 V and the current in each LED is 25 mA.

Determine the value of the resistor in series with each LED.

4

Space for working and answer



* X 8 5 7 7 5 0 1 2 0 *

6. (continued)

MARKS

DO NOT
WRITE IN
THIS
MARGIN

- (c) When the battery is completely discharged it then takes 6.0 hours of direct sunlight to fully charge the battery. During this time, there is a constant current of 0.135 A to the battery.

Calculate the total charge supplied to the battery during this time.

3

Space for working and answer

[Turn over



* X 8 5 7 7 5 0 1 2 1 *

7. A filament lamp consists of a thin coil of resistance wire surrounded by a low pressure gas, enclosed in a glass bulb.

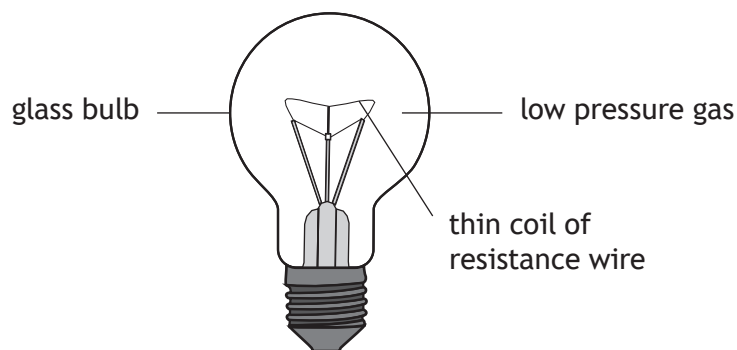

Using your knowledge of physics, comment on the suitability of this design as a light source.

3



[Turn over for next question

DO NOT WRITE ON THIS PAGE



* X 8 5 7 7 5 0 1 2 3 *

8. A student carries out an experiment, using the apparatus shown, to determine a value for the specific heat capacity of water.

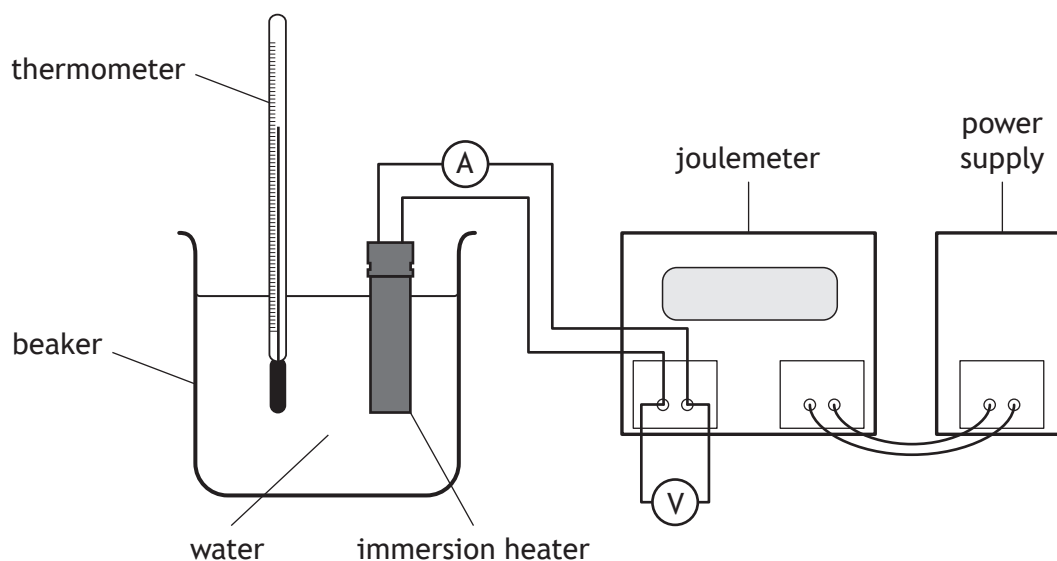

The student switches on the power supply and the immersion heater heats the water.

The joulemeter measures the energy supplied to the immersion heater.

The student records the following measurements.

energy supplied to immersion heater = 21 600 J

mass of water = 0.50 kg

initial temperature of the water = 16 °C

final temperature of the water = 24 °C

reading on voltmeter = 12 V

reading on ammeter = 4.0 A

- (a) (i) Determine the value of the specific heat capacity of water obtained from these measurements.

3

Space for working and answer



8. (a) (continued)

MARKS

DO NOT
WRITE IN
THIS
MARGIN

(ii) Explain why the value determined from the experiment is different from the value quoted in the data sheet.

1

(b) Calculate the time for which the immersion heater is switched on in this experiment.

4

Space for working and answer

[Turn over



* X 8 5 7 7 5 0 1 2 5 *

8. (continued)

MARKS
DO NOT
WRITE IN
THIS
MARGIN

- (c) The student then carries out a second experiment, using the apparatus shown, to determine a value for the specific latent heat of vaporisation of water.

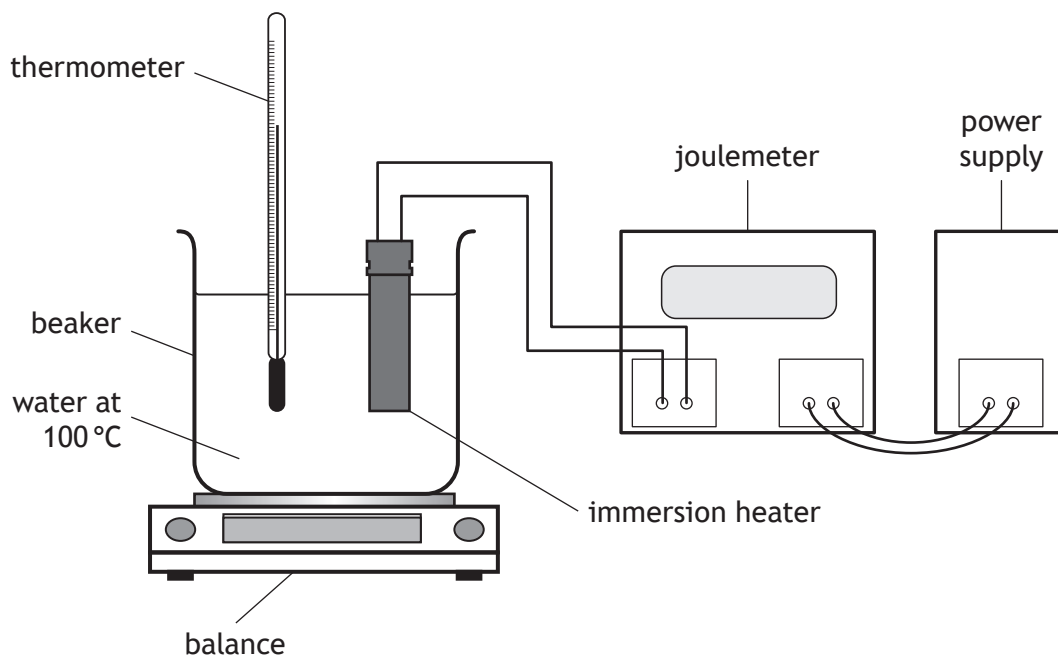

Describe how this apparatus would be used to determine a value for the specific latent heat of vaporisation of water.

3

Your description must include:

- measurements made
- any necessary calculations



[Turn over for next question

DO NOT WRITE ON THIS PAGE



* X 8 5 7 7 5 0 1 2 7 *

9. A student sets up an experiment to investigate the relationship between the pressure and temperature of a fixed mass of gas as shown.

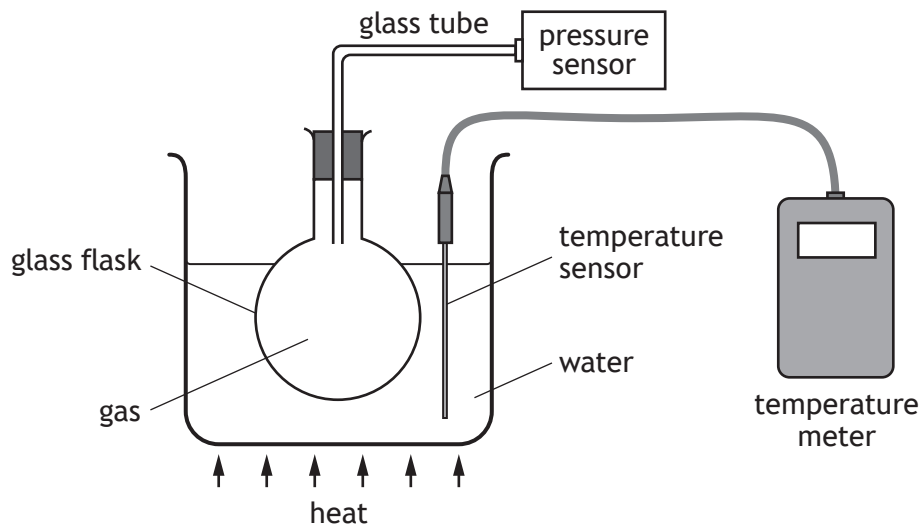

- (a) The student heats the water and records the following readings of pressure and temperature.

<i>Pressure (kPa)</i>	101	107	116	122
<i>Temperature (K)</i>	293	313	333	353

- (i) Using **all** the data, establish the relationship between the pressure and the temperature of the gas.

3

Space for working and answer



9. (a) (continued)

MARKS

DO NOT
WRITE IN
THIS
MARGIN

(ii) Using the kinetic model, explain why the pressure of the gas increases as its temperature increases.

3

(iii) Predict the pressure reading which would be obtained if the student was to cool the gas to 253 K.

1

(b) State one way in which the set-up of the experiment could be improved to give more reliable results.

Justify your answer.

2

[Turn over



* X 8 5 7 7 5 0 1 2 9 *

10. A student connects a mobile phone to a speaker wirelessly using a microwave signal.



not to scale



- (a) The time taken for the microwave signal to travel from the mobile phone to the speaker is 2.1×10^{-8} s.

Calculate the distance between the mobile phone and the speaker.

3

Space for working and answer

- (b) Sound is a longitudinal wave.

The sound produced by the speaker is represented by the following diagram.

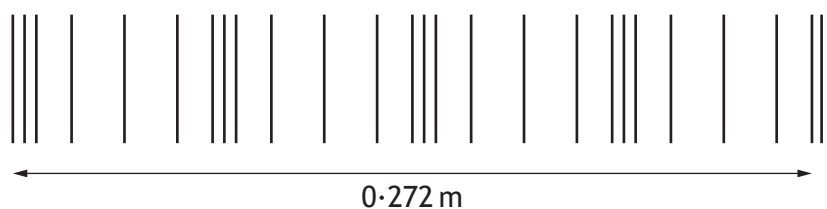

- (i) State what is meant by the term *longitudinal wave*.

1



MARKS

DO NOT
WRITE IN
THIS
MARGIN

10. (b) (continued)

(ii) Determine the wavelength of the sound wave.

Space for working and answer

1

(iii) Calculate the frequency of the sound wave in air.

Space for working and answer

3

[Turn over



* X 8 5 7 7 5 0 1 3 1 *

11. A rain sensor is attached to the glass windscreen of a vehicle to automatically control the windscreen wipers.

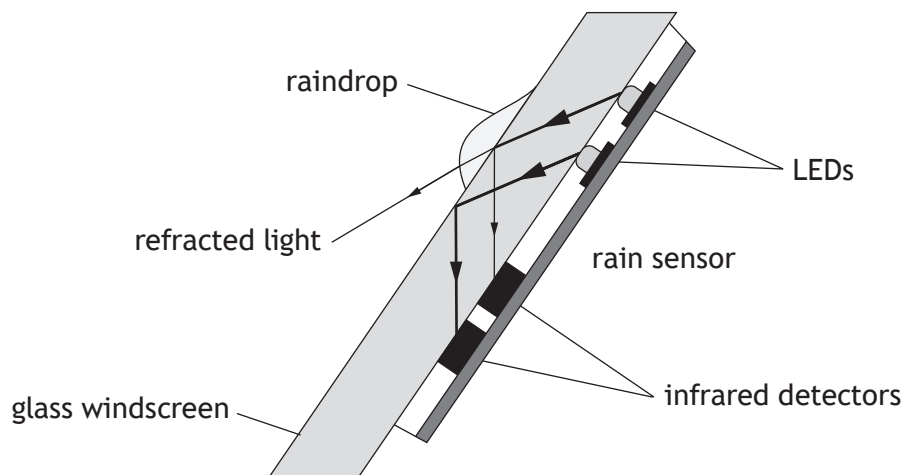

Infrared light is emitted from LEDs and is received by infrared detectors.

- (a) State a suitable detector of infrared radiation for this rain sensor.

1



- (b) The graph shows how the number of raindrops affects the percentage of infrared light received by the infrared detectors.

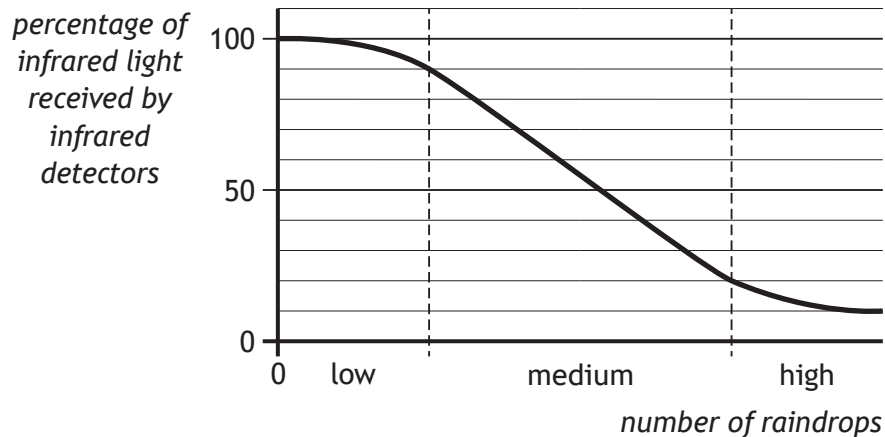

The percentage of infrared light received by the infrared detectors from the LEDs controls the frequency with which the windscreen wipers move back and forth.

The table shows how the number of times the windscreen wipers move back and forth per minute relates to the number of raindrops.

<i>Number of raindrops</i>	<i>Number of times the windscreen wipers move back and forth per minute</i>
low	18
medium	54
high	78

At one point in time the infrared detectors receive 70% of the infrared light emitted from the LEDs.

Show that the frequency of the windscreen wipers at this time is 0.90 Hz. 3

Space for working and answer

[Turn over



* X 8 5 7 7 5 0 1 3 3 *

11. (continued)

MARKS

DO NOT
WRITE IN
THIS
MARGIN

- (c) Some of the infrared light is refracted when travelling from the glass windscreen into a raindrop.

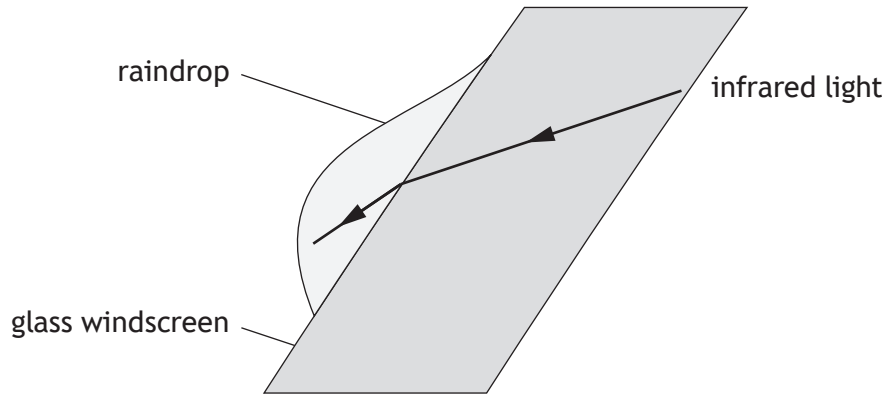

- (i) On the diagram, draw and label:
- (A) a normal; 1
 - (B) an angle of incidence i and an angle of refraction r . 1
- (An additional diagram, if required, can be found on page 44.)
- (ii) State whether the wavelength of the infrared light in the raindrop is less than, equal to or greater than the wavelength of the infrared light in the glass. 2
- You must justify your answer.



* X 8 5 7 7 5 0 1 3 4 *

[Turn over for next question

DO NOT WRITE ON THIS PAGE



* X 8 5 7 7 5 0 1 3 5 *

12. A tritium torch includes a sealed glass capsule containing radioactive tritium gas.

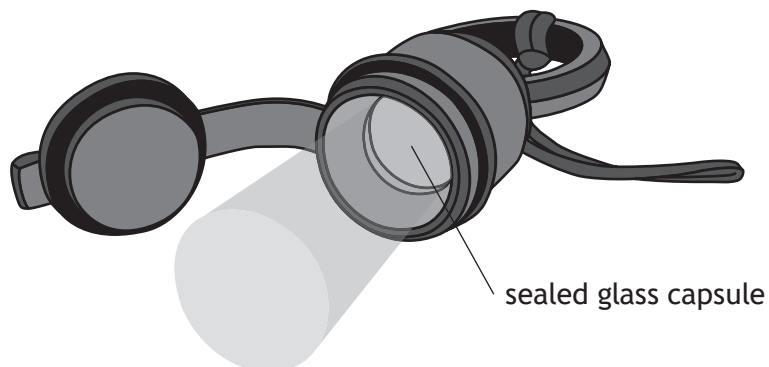

Beta particles emitted by the tritium gas are absorbed by a coating on the inside of the glass capsule.

The coating then emits visible light.

- (a) State what is meant by a *beta particle*. 1

- (b) The half-life of tritium gas is 12.3 years.
The manufacturer states that the torch will work effectively for 15 years.
Explain why the torch will be less effective after this time. 2



12. (continued)

MARKS

DO NOT
WRITE IN
THIS
MARGIN

- (c) During the manufacturing process a glass capsule cracks and a worker receives an absorbed dose of 0.40 mGy throughout their body from the tritium gas.

The mass of the worker is 85 kg.

- (i) Calculate the energy of the radiation absorbed by the worker.

3

Space for working and answer

- (ii) Calculate the equivalent dose received by the worker.

3

Space for working and answer

[Turn over



* X 8 5 7 7 5 0 1 3 7 *

[BLANK PAGE]

DO NOT WRITE ON THIS PAGE



* X 8 5 7 7 5 0 1 3 8 *

13. A technician carries out an experiment, using the apparatus shown, to determine the half-life of a gamma radiation source.

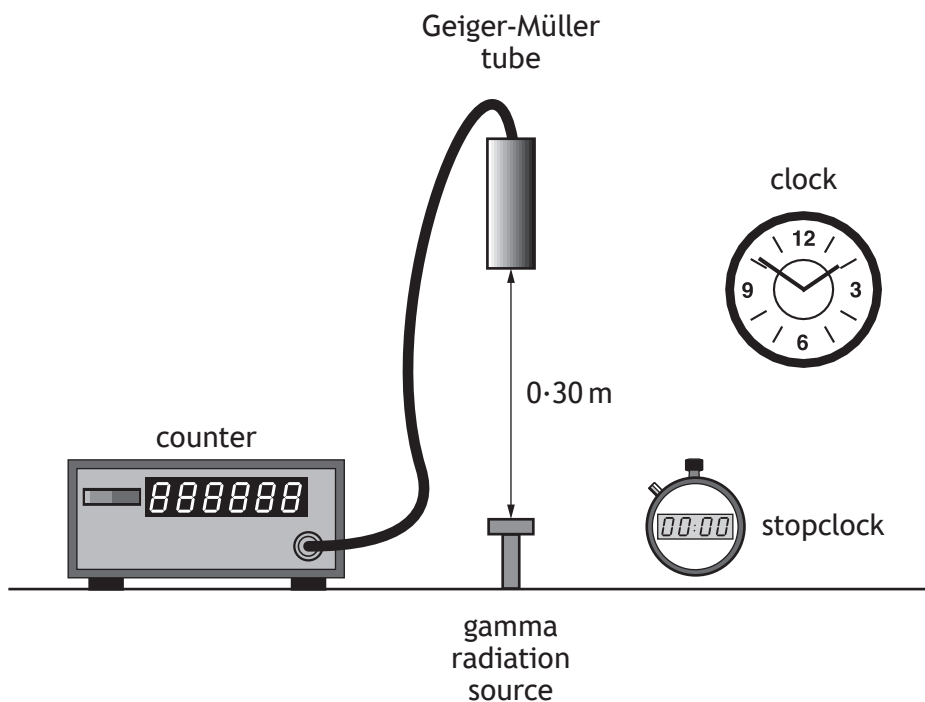

- (a) Before carrying out the experiment the technician measures the background count rate.

(i) Explain why this measurement is made.

1

(ii) State a source of background radiation.

1

[Turn over



* X 8 5 7 7 5 0 1 3 9 *

13. (continued)

MARKS
DO NOT
WRITE IN
THIS
MARGIN

(b) The technician's results are shown in the table.

<i>Time</i> (minutes)	<i>Corrected count rate</i> (counts per minute)
0	680
20	428
40	270
60	170
80	107
100	68

(i) Using the graph paper below, draw a graph of these results.

3

(Additional graph paper, if required, can be found on *page 45*.)

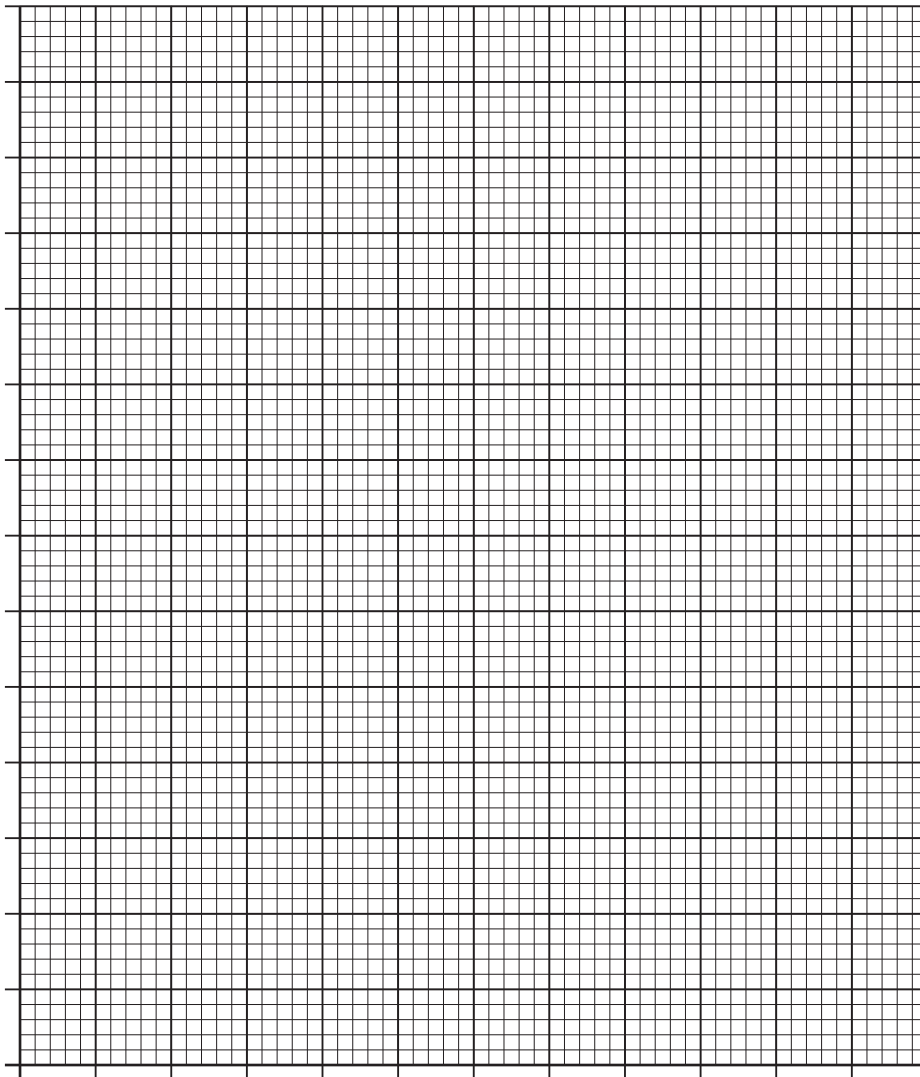

13. (b) (continued)

MARKS
DO NOT
WRITE IN
THIS
MARGIN

(ii) Use your graph to determine the half-life of the gamma radiation source.

1

(c) The technician repeats the experiment with an alpha radiation source.

(i) Suggest a change the technician must make to the experimental set-up to determine the half-life of the alpha radiation source.

Justify your answer.

2

(ii) During the first 15 s of the experiment the alpha radiation source has an average activity of 520 Bq.

Calculate the number of nuclear disintegrations that occur in the source in the first 15 s of the experiment.

3

Space for working and answer

[END OF QUESTION PAPER]



* X 8 5 7 7 5 0 1 4 1 *

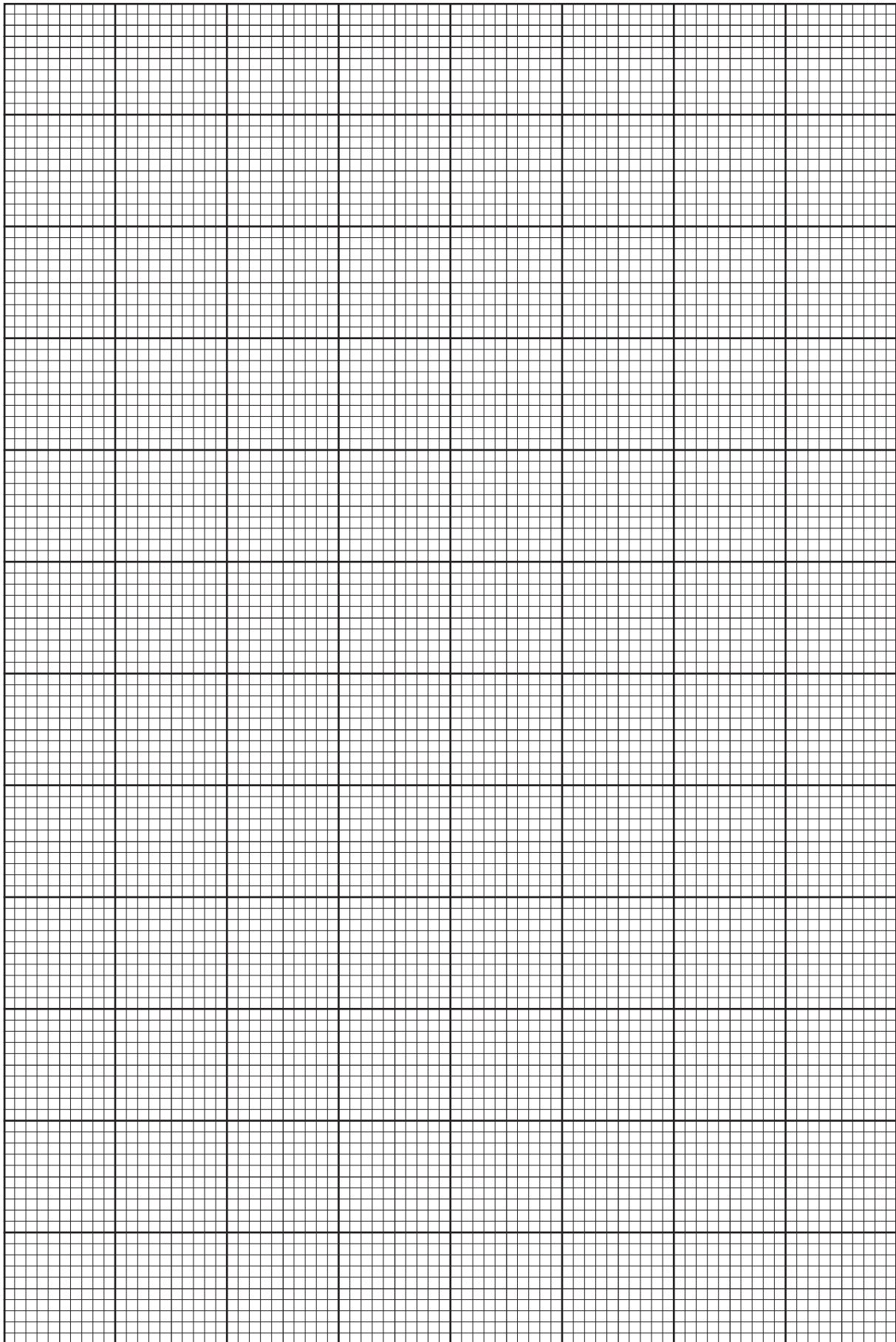

* X 8 5 7 7 5 0 1 4 2 *

ADDITIONAL SPACE FOR ANSWERS AND ROUGH WORKING

Additional diagram for Q2 (c)

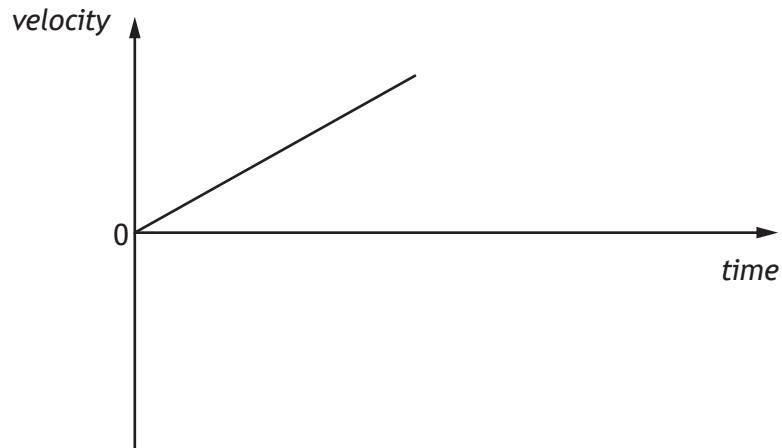

Additional diagram for Q3 (c)

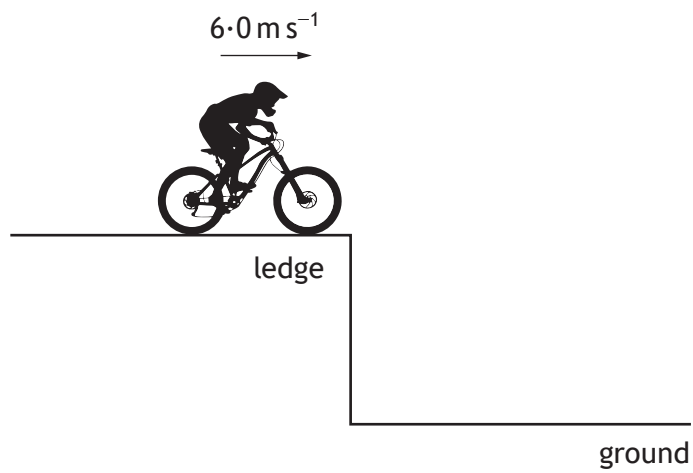

* X 8 5 7 7 5 0 1 4 3 *

MARKS

DO NOT
WRITE IN
THIS
MARGIN

ADDITIONAL SPACE FOR ANSWERS AND ROUGH WORKING

Additional diagram for Q11 (c)

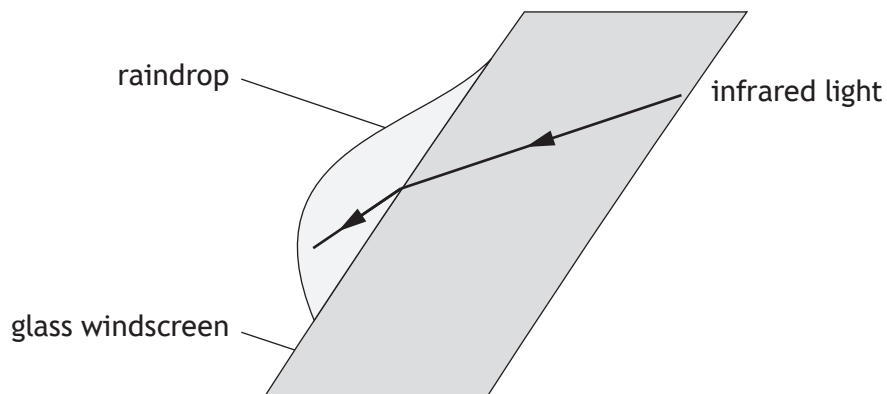

* X 8 5 7 7 5 0 1 4 4 *

MARKS

DO NOT
WRITE IN
THIS
MARGIN

ADDITIONAL SPACE FOR ANSWERS AND ROUGH WORKING

Additional graph paper for Q13 (b) (i)

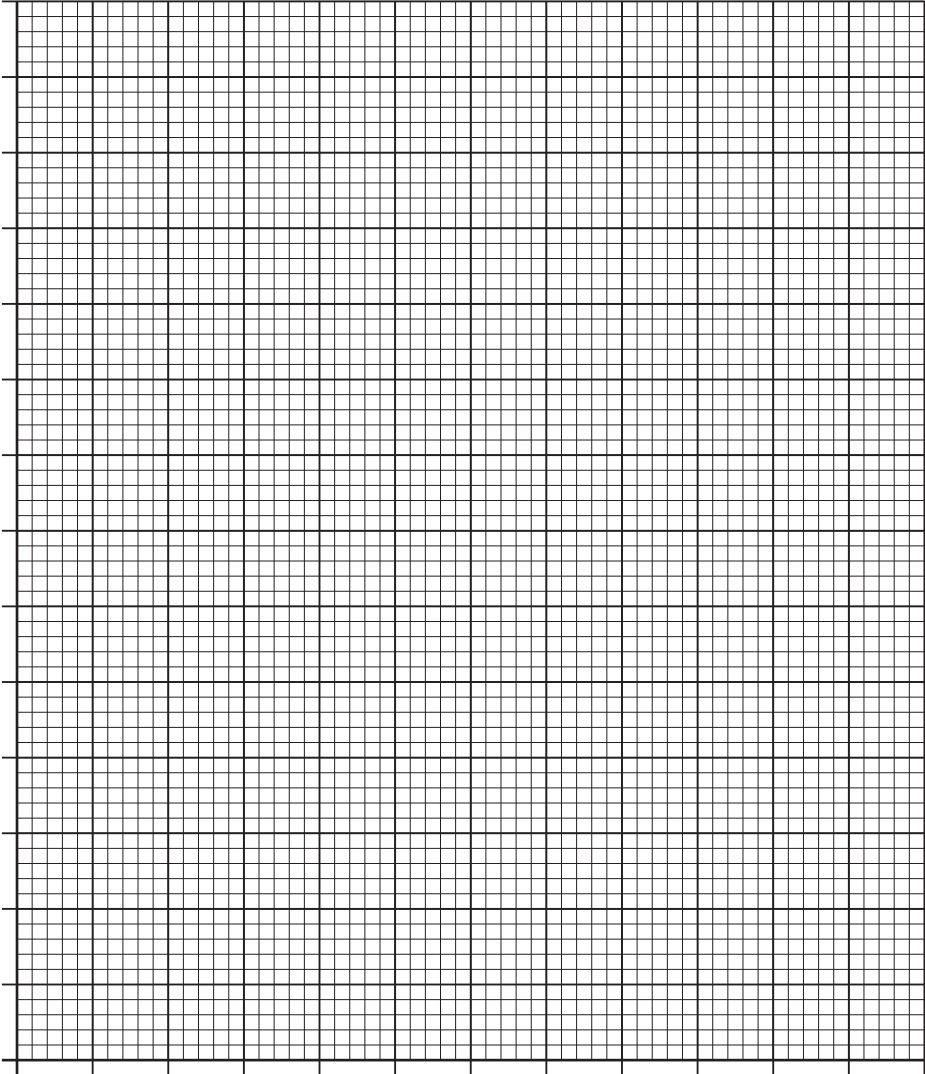



MARKS

DO NOT
WRITE IN
THIS
MARGIN

ADDITIONAL SPACE FOR ANSWERS AND ROUGH WORKING

--



* X 8 5 7 7 5 0 1 4 6 *

MARKS

DO NOT
WRITE IN
THIS
MARGIN

ADDITIONAL SPACE FOR ANSWERS AND ROUGH WORKING



* X 8 5 7 7 5 0 1 4 7 *

ACKNOWLEDGEMENTS

Question 5 – Image is taken from <https://pixabay.com/en/astronauts-floating-fruit-space-625540/>.
Licensed under CCO Creative Commons.

Question 10 – SpeedKingz/Shutterstock.com
arslaan/Shutterstock.com
Atiketta Sangasaeng/Shutterstock.com



* X 8 5 7 7 5 0 1 4 8 *