



National
Qualifications
2021 ASSESSMENT RESOURCE

X857/75/02

Physics
Section 1 — Questions

Duration — 2 hours 30 minutes

Instructions for the completion of Section 1 are given on *page 02* of your question and answer booklet X857/75/01.

Record your answers on the answer grid on *page 03* of your question and answer booklet.

Reference may be made to the Data sheet on *page 02* of this booklet and to the Relationships sheet X857/75/11.

Before leaving the examination room you must give your question and answer booklet to the Invigilator; if you do not, you may lose all the marks for this paper.



* X 8 5 7 7 5 0 2 *

DATA SHEET

Speed of light in materials

Material	Speed in m s^{-1}
Air	3.0×10^8
Carbon dioxide	3.0×10^8
Diamond	1.2×10^8
Glass	2.0×10^8
Glycerol	2.1×10^8
Water	2.3×10^8

Gravitational field strengths

	Gravitational field strength on the surface in N kg^{-1}
Earth	9.8
Jupiter	23
Mars	3.7
Mercury	3.7
Moon	1.6
Neptune	11
Saturn	9.0
Sun	270
Uranus	8.7
Venus	8.9

Specific latent heat of fusion of materials

Material	Specific latent heat of fusion in J kg^{-1}
Alcohol	0.99×10^5
Aluminium	3.95×10^5
Carbon Dioxide	1.80×10^5
Copper	2.05×10^5
Iron	2.67×10^5
Lead	0.25×10^5
Water	3.34×10^5

Specific latent heat of vaporisation of materials

Material	Specific latent heat of vaporisation in J kg^{-1}
Alcohol	11.2×10^5
Carbon Dioxide	3.77×10^5
Glycerol	8.30×10^5
Turpentine	2.90×10^5
Water	22.6×10^5

Speed of sound in materials

Material	Speed in m s^{-1}
Aluminium	5200
Air	340
Bone	4100
Carbon dioxide	270
Glycerol	1900
Muscle	1600
Steel	5200
Tissue	1500
Water	1500

Specific heat capacity of materials

Material	Specific heat capacity in $\text{J kg}^{-1} \text{ }^\circ\text{C}^{-1}$
Alcohol	2350
Aluminium	902
Copper	386
Glass	500
Ice	2100
Iron	480
Lead	128
Oil	2130
Water	4180

Melting and boiling points of materials

Material	Melting point in $^\circ\text{C}$	Boiling point in $^\circ\text{C}$
Alcohol	-98	65
Aluminium	660	2470
Copper	1077	2567
Lead	328	1737
Iron	1537	2737
Water	-	100

Radiation weighting factors

Type of radiation	Radiation weighting factor
alpha	20
beta	1
fast neutrons	10
gamma	1
slow neutrons	3
X-rays	1

SECTION 1

Attempt ALL questions

1. Which of the following is a vector quantity?
- A force
 - B distance
 - C mass
 - D time
 - E energy
2. A skydiver falling from an aircraft reaches terminal velocity because
- A the air is very thin at high altitude
 - B there is very little friction acting on the skydiver
 - C gravitational field strength is less at high altitude
 - D the skydiver's weight is balanced by air friction
 - E the skydiver is streamlined.
3. A block of mass 5.0 kg is placed on a smooth, horizontal surface. Two forces are applied to the block as shown.

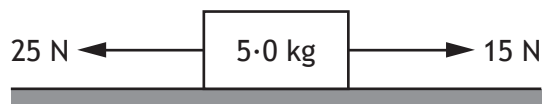

The acceleration of the block is

- A 0.50 m s^{-2}
- B 2.0 m s^{-2}
- C 3.0 m s^{-2}
- D 5.0 m s^{-2}
- E 8.0 m s^{-2} .

[Turn over

4. A student designs an experiment to investigate the relationship between the extension y of a spring and the magnitude of the force F applied to it. Different masses are attached to the spring and the length of the spring is recorded for each mass.

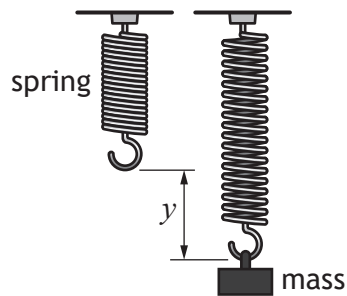

The relationship between F and y is

$$F = ky$$

where k is the spring constant of the spring.

The length of the spring with no mass attached is 0.080 m.

When a mass is attached to the spring, the length of the spring increases to 0.110 m.

The spring constant of the spring is 12 N m^{-1} .

The magnitude of the force applied to the spring is

- A 0.0025 N
- B 0.36 N
- C 1.3 N
- D 2.3 N
- E 400 N.

5. An arrow is fired horizontally with a velocity of 60 m s^{-1} .

The effects of air resistance on the arrow can be ignored.

Which pair of graphs shows how the horizontal velocity v_h and vertical velocity v_v of the arrow varies with time t during the first second of its flight?

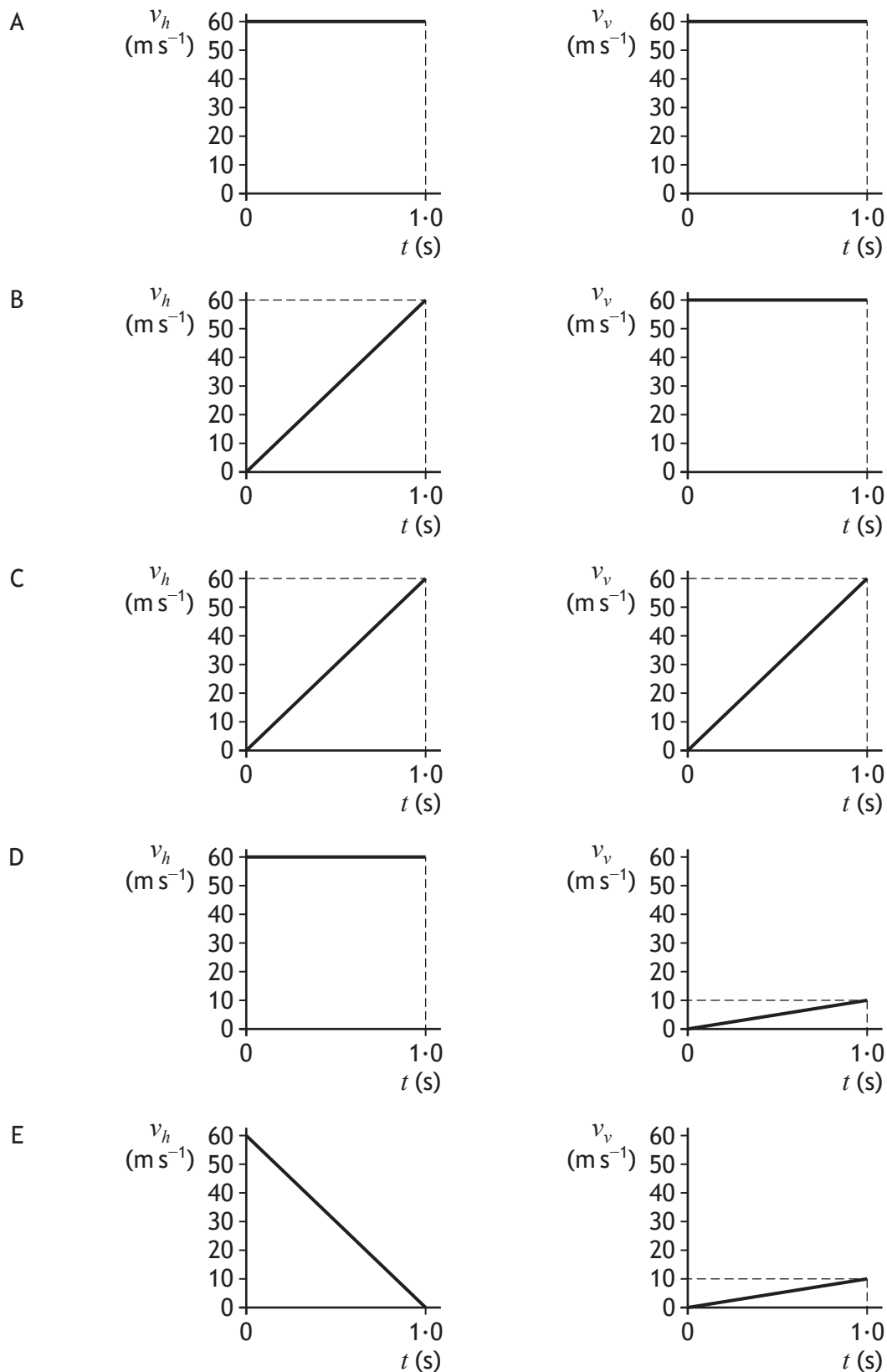

[Turn over

6. A satellite orbits the Earth at an altitude of 540 km.

The graph shows how gravitational field strength varies with altitude.

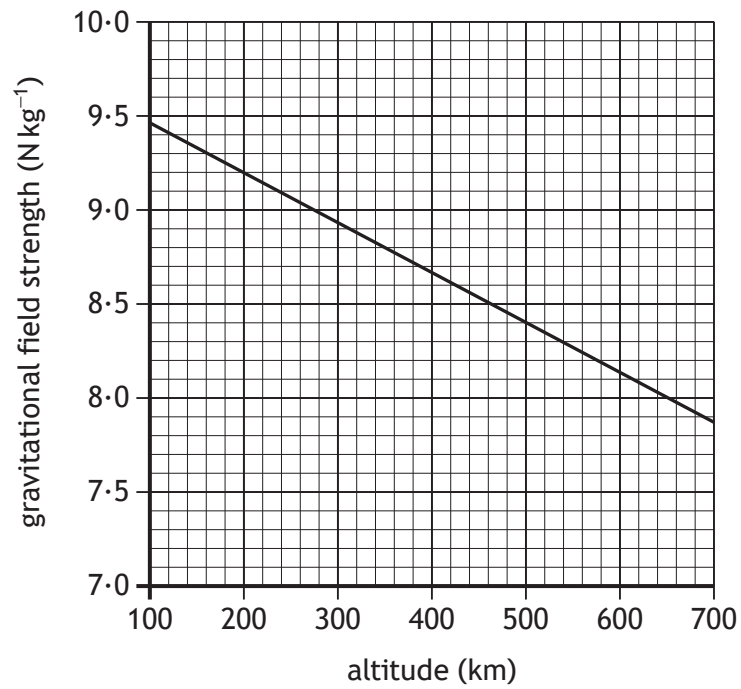

The mass of the satellite is 78 kg.

The weight of the satellite at this altitude is

- A 620 N
- B 640 N
- C 650 N
- D 740 N
- E 760 N.

7. A student makes the following statements about geostationary satellites in orbit around the Earth.
- I The orbital period of a geostationary satellite is 24 hours.
 - II Geostationary satellites remain above the same point on the Earth's surface.
 - III Geostationary satellites orbit at different altitudes.

Which of these statements is/are correct?

- A I only
 - B II only
 - C I and II only
 - D II and III only
 - E I, II and III
8. A star is 2.4×10^{18} m from Earth.

This distance in light-years is

- A 3.9×10^{-3}
- B 2.5×10^2
- C 1.5×10^4
- D 8.0×10^9
- E 9.5×10^{15} .

[Turn over

9. Light from a star is split into a line spectrum of different colours. The line spectrum from the star is shown, along with the line spectra of the elements calcium, helium, hydrogen, and sodium.

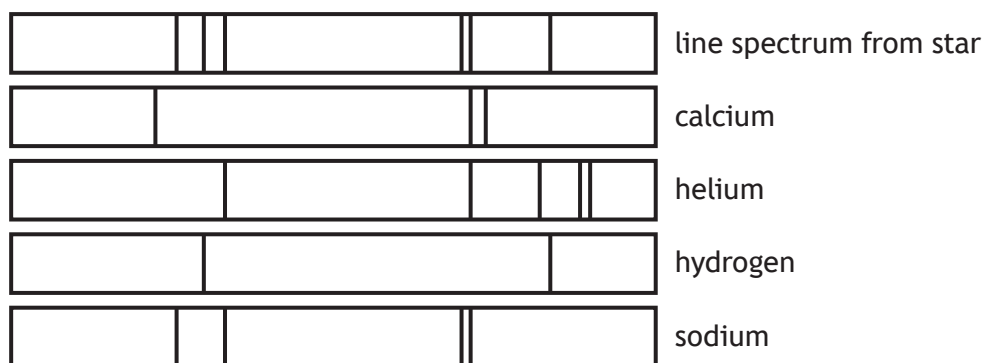

The elements present in this star are

- A sodium and calcium
- B calcium and helium
- C hydrogen and sodium
- D helium and hydrogen
- E calcium, sodium and hydrogen.

10. A heating element is connected to a 12 V supply.
The power rating of the heating element is 48 W.
The charge that passes through the heating element in 5 minutes is

- A 0.80 C
- B 1.25 C
- C 20 C
- D 75 C
- E 1200 C.

11. An oscilloscope is used to test three different power supplies.
The diagrams represent the traces seen on the screen of the oscilloscope.

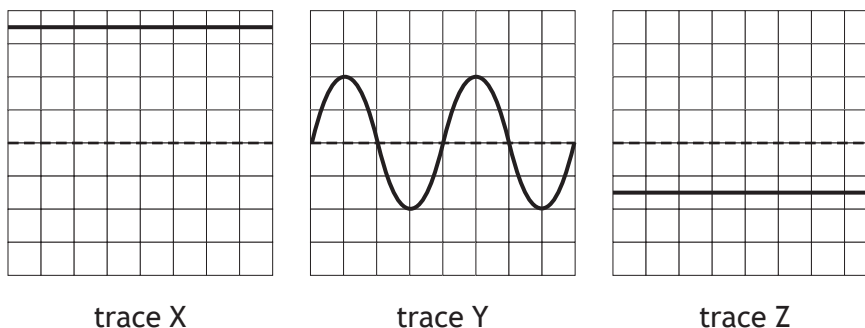

Which of these traces represent a d.c. signal?

- A X only
- B Y only
- C X and Y only
- D X and Z only
- E X, Y and Z

[Turn over

12. The graph shows how the voltage varies with current for three resistors X, Y and Z.

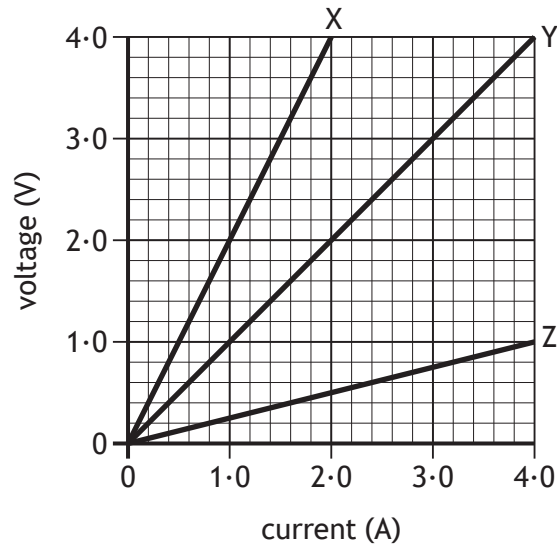

A student makes the following statements using information from the graph.

- I The resistance of resistor X is greater than that of resistors Y and Z.
- II When the voltage across resistor Y is 2.0 V, the current in the resistor is 2.0 A.
- III The resistance of resistor Z is 0.25 Ω .

Which of these statements is/are correct?

- A I only
- B II only
- C III only
- D II and III only
- E I, II and III

13. In which of the following circuits would the readings on the meters allow the resistance of R_2 to be calculated?

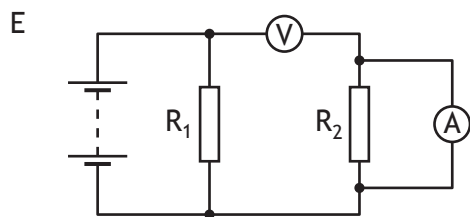
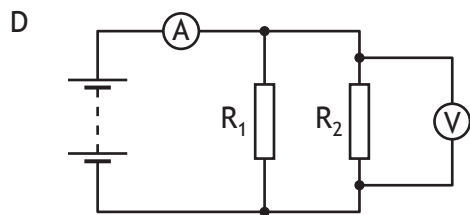
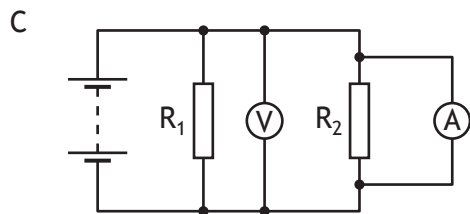
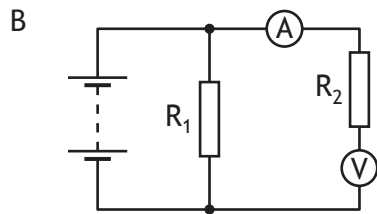
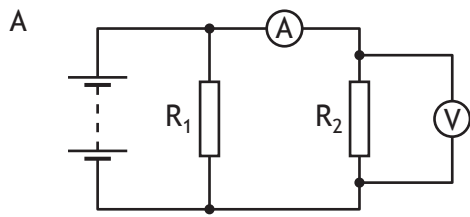

[Turn over

14. A heater is immersed in a substance.

The heater is then switched on.

The graph shows the temperature T of the substance over a period of time t .

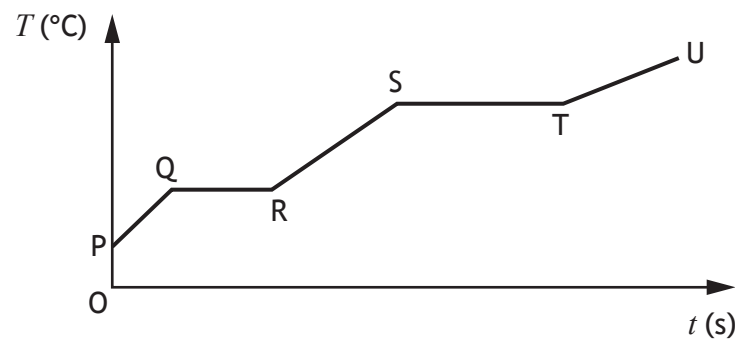

Which row in the table identifies the sections of the graph when the substance is changing state from a solid to a liquid and from a liquid to a gas?

	solid to liquid	liquid to gas
A	QR	TU
B	QR	ST
C	PQ	RS
D	PQ	TU
E	ST	QR

15. A sample of water is at a temperature of $100\text{ }^{\circ}\text{C}$.
The sample absorbs $9.0 \times 10^4\text{ J}$ of energy.
The mass of water changed to steam at $100\text{ }^{\circ}\text{C}$ is

- A 0.027 kg
- B 0.040 kg
- C 0.22 kg
- D 22 kg
- E 25 kg.

16. A solid rectangular block is placed on a flat, smooth table as shown.

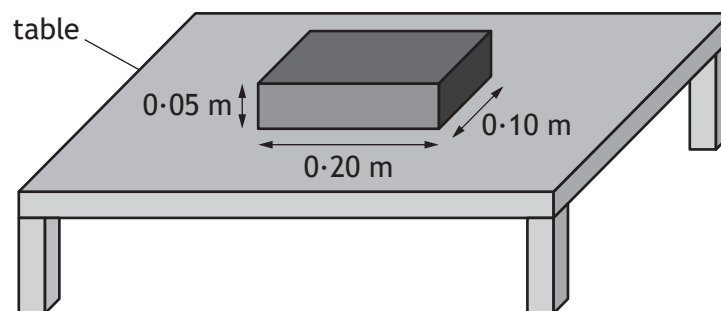

The weight of the block is 28 N.
The pressure exerted on the table by the block is

- A 140 Pa
 - B 280 Pa
 - C 560 Pa
 - D 1400 Pa
 - E 28 000 Pa.
17. A gas is contained inside a sealed syringe.
The volume of the gas in the syringe is decreased.
During this time the temperature of the gas is unchanged.
This change in volume causes the gas particles to
- A move faster
 - B hit the walls of the syringe less often
 - C move slower
 - D gain kinetic energy
 - E hit the walls of the syringe more often.

[Turn over

18. A liquid is heated from 22 °C to 64 °C.

The temperature rise in kelvin is

- A 42 K
- B 86 K
- C 315 K
- D 337 K
- E 359 K.

19. Five water waves pass a point in a time of 10 seconds.

Which row in the table shows the frequency of the waves and the period of the waves?

	Frequency of the waves (Hz)	Period of the waves (s)
A	0.5	2
B	0.5	0.5
C	2	0.5
D	50	0.02
E	50	2

20. A ray of red light travels from air into a glass block.

Which row in the table shows the effect, if any, on the wavelength and speed of the red light as it passes into the glass block?

	Wavelength	Speed
A	decreases	stays the same
B	stays the same	increases
C	decreases	decreases
D	stays the same	decreases
E	increases	increases

21. Which of the following diagrams shows the path of a ray of red light as it passes from air into a glass block?

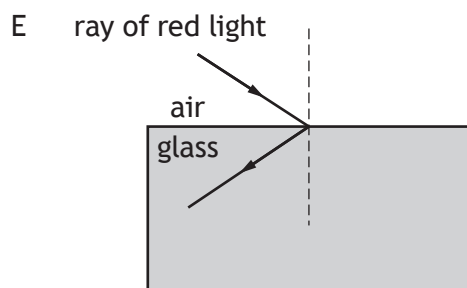
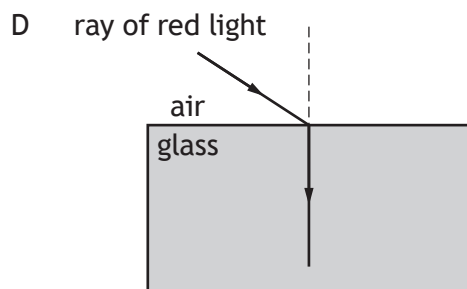
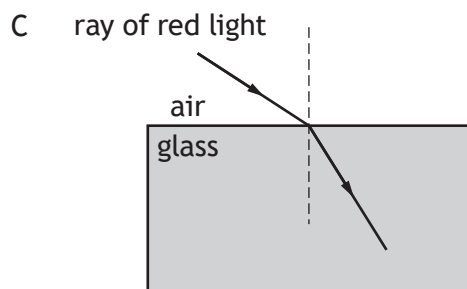
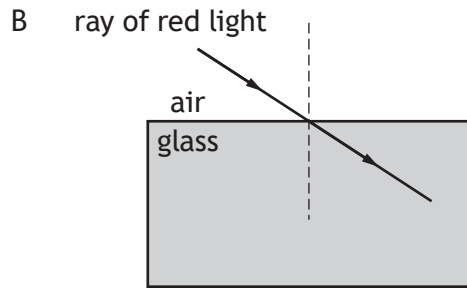
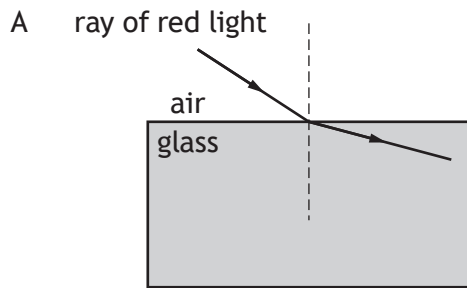

[Turn over

22. A uniform electric field exists between two oppositely charged parallel metal plates. An alpha particle, a beta particle and a gamma ray each pass between the metal plates. They follow different paths as shown.

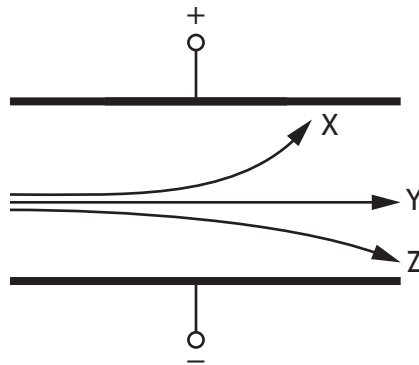

Which row in the table shows the types of radiation that follow paths X, Y and Z?

	Type of radiation that follows path X	Type of radiation that follows path Y	Type of radiation that follows path Z
A	alpha	beta	gamma
B	alpha	gamma	beta
C	beta	alpha	gamma
D	beta	gamma	alpha
E	gamma	alpha	beta

23. During ionisation an atom becomes a positive ion.
Which of the following has been removed from the atom?
- A An electron
 - B An alpha particle
 - C A proton
 - D A neutron
 - E A gamma ray

24. A Geiger-Müller tube connected to a counter is placed in front of a radioactive source.

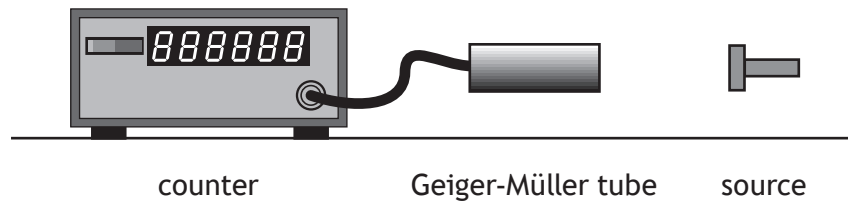

The number of counts recorded in one minute is 3890.

Different shielding materials are now placed in turn between the source and the Geiger-Müller tube, and the number of counts per minute is recorded.

Shielding material	Number of counts per minute
no shielding material	3890
sheet of paper	2110
1 cm of aluminium	2112
5 cm of lead	365

The source is emitting

- A alpha radiation only
- B beta radiation only
- C alpha and beta radiation only
- D alpha and gamma radiation only
- E beta and gamma radiation only.

25. During radiation treatment, a patient's liver absorbs 90 μJ of gamma radiation.

The mass of the liver is 2.0 kg.

The absorbed dose received by the liver is

- A 45 μGy
- B 88 μGy
- C 90 μGy
- D 92 μGy
- E 180 μGy .

[END OF SECTION 1. NOW ATTEMPT THE QUESTIONS IN SECTION 2 OF YOUR QUESTION AND ANSWER BOOKLET]

[BLANK PAGE]

DO NOT WRITE ON THIS PAGE

[BLANK PAGE]

DO NOT WRITE ON THIS PAGE

[BLANK PAGE]

DO NOT WRITE ON THIS PAGE

FOR OFFICIAL USE



National
Qualifications
2021 ASSESSMENT RESOURCE

Mark

X857/75/01

**Physics
Section 1 — Answer grid
and Section 2**

Duration — 2 hours 30 minutes



Fill in these boxes and read what is printed below.

Full name of centre

Town

Forename(s)

Surname

Number of seat

Date of birth

Day

Month

Year

Scottish candidate number

Total marks — 135

SECTION 1 — 25 marks

Attempt ALL questions.

Instructions for completion of Section 1 are given on *page 02*.

SECTION 2 — 110 marks

Attempt ALL questions.

Reference may be made to the Data sheet on *page 02* of the question paper X857/75/02 and to the Relationships sheet X857/75/11.

Write your answers clearly in the spaces provided in this booklet. Additional space for answers and rough work is provided at the end of this booklet. If you use this space you must clearly identify the question number you are attempting. Any rough work must be written in this booklet. Score through your rough work when you have written your final copy.

Use **blue** or **black** ink.

Before leaving the examination room you must give this booklet to the Invigilator; if you do not, you may lose all the marks for this paper.



The questions for Section 1 are contained in the question paper X857/75/02.

Read these and record your answers on the answer grid on *page 03* opposite.

Use **blue** or **black** ink. Do NOT use gel pens or pencil.

1. The answer to each question is **either** A, B, C, D or E. Decide what your answer is, then fill in the appropriate bubble (see sample question below).
2. There is **only one correct** answer to each question.
3. Any rough work must be written in the additional space for answers and rough work at the end of this booklet.

Sample question

The energy unit measured by the electricity meter in your home is the

- A ampere
- B kilowatt-hour
- C watt
- D coulomb
- E volt.

The correct answer is **B** — kilowatt-hour. The answer **B** bubble has been clearly filled in (see below).

A	B	C	D	E
<input type="radio"/>	<input checked="" type="radio"/>	<input type="radio"/>	<input type="radio"/>	<input type="radio"/>

Changing an answer

If you decide to change your answer, cancel your first answer by putting a cross through it (see below) and fill in the answer you want. The answer below has been changed to **D**.

A	B	C	D	E
<input type="radio"/>	<input checked="" type="radio"/>	<input type="radio"/>	<input checked="" type="radio"/>	<input type="radio"/>

If you then decide to change back to an answer you have already scored out, put a tick (✓) to the **right** of the answer you want, as shown below:

A	B	C	D	E	or	A	B	C	D	E
<input type="radio"/>	<input checked="" type="radio"/>	<input type="radio"/>	<input checked="" type="radio"/>	<input type="radio"/>		<input type="radio"/>	<input checked="" type="radio"/>	<input type="radio"/>	<input type="radio"/>	<input type="radio"/>



SECTION 1 — Answer grid



* O B J 2 5 A E 1 *

	A	B	C	D	E
1	<input type="radio"/>	<input type="radio"/>	<input type="radio"/>	<input type="radio"/>	<input type="radio"/>
2	<input type="radio"/>	<input type="radio"/>	<input type="radio"/>	<input type="radio"/>	<input type="radio"/>
3	<input type="radio"/>	<input type="radio"/>	<input type="radio"/>	<input type="radio"/>	<input type="radio"/>
4	<input type="radio"/>	<input type="radio"/>	<input type="radio"/>	<input type="radio"/>	<input type="radio"/>
5	<input type="radio"/>	<input type="radio"/>	<input type="radio"/>	<input type="radio"/>	<input type="radio"/>
6	<input type="radio"/>	<input type="radio"/>	<input type="radio"/>	<input type="radio"/>	<input type="radio"/>
7	<input type="radio"/>	<input type="radio"/>	<input type="radio"/>	<input type="radio"/>	<input type="radio"/>
8	<input type="radio"/>	<input type="radio"/>	<input type="radio"/>	<input type="radio"/>	<input type="radio"/>
9	<input type="radio"/>	<input type="radio"/>	<input type="radio"/>	<input type="radio"/>	<input type="radio"/>
10	<input type="radio"/>	<input type="radio"/>	<input type="radio"/>	<input type="radio"/>	<input type="radio"/>
11	<input type="radio"/>	<input type="radio"/>	<input type="radio"/>	<input type="radio"/>	<input type="radio"/>
12	<input type="radio"/>	<input type="radio"/>	<input type="radio"/>	<input type="radio"/>	<input type="radio"/>
13	<input type="radio"/>	<input type="radio"/>	<input type="radio"/>	<input type="radio"/>	<input type="radio"/>
14	<input type="radio"/>	<input type="radio"/>	<input type="radio"/>	<input type="radio"/>	<input type="radio"/>
15	<input type="radio"/>	<input type="radio"/>	<input type="radio"/>	<input type="radio"/>	<input type="radio"/>
16	<input type="radio"/>	<input type="radio"/>	<input type="radio"/>	<input type="radio"/>	<input type="radio"/>
17	<input type="radio"/>	<input type="radio"/>	<input type="radio"/>	<input type="radio"/>	<input type="radio"/>
18	<input type="radio"/>	<input type="radio"/>	<input type="radio"/>	<input type="radio"/>	<input type="radio"/>
19	<input type="radio"/>	<input type="radio"/>	<input type="radio"/>	<input type="radio"/>	<input type="radio"/>
20	<input type="radio"/>	<input type="radio"/>	<input type="radio"/>	<input type="radio"/>	<input type="radio"/>
21	<input type="radio"/>	<input type="radio"/>	<input type="radio"/>	<input type="radio"/>	<input type="radio"/>
22	<input type="radio"/>	<input type="radio"/>	<input type="radio"/>	<input type="radio"/>	<input type="radio"/>
23	<input type="radio"/>	<input type="radio"/>	<input type="radio"/>	<input type="radio"/>	<input type="radio"/>
24	<input type="radio"/>	<input type="radio"/>	<input type="radio"/>	<input type="radio"/>	<input type="radio"/>
25	<input type="radio"/>	<input type="radio"/>	<input type="radio"/>	<input type="radio"/>	<input type="radio"/>



* X 8 5 7 7 5 0 1 0 3 *

[BLANK PAGE]

DO NOT WRITE ON THIS PAGE



* X 8 5 7 7 5 0 1 0 4 *

SECTION 2 — 110 marks

Attempt ALL questions

1. A ferry makes a crossing from port A on the island of Islay to port B on the island of Jura.

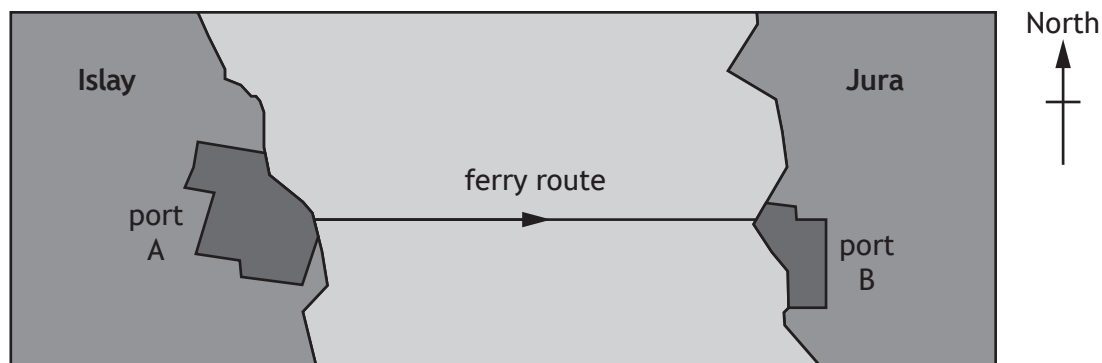

Port B is 870 m due East (090) of port A.

- (a) The ferry travels directly from port A to port B at an average speed of 2.9 m s^{-1} .

- (i) Calculate the time taken for this crossing.

3

Space for working and answer

- (ii) State the average velocity of the ferry for this crossing.

1

[Turn over



1. (continued)

- (b) The graph shows how the speed of the ferry varies during the first 30 s of the crossing.

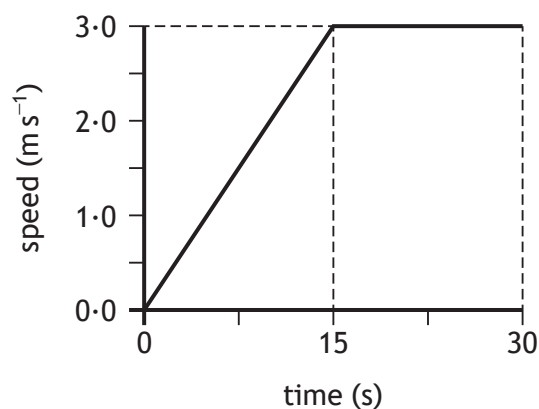

- (i) Determine the acceleration of the ferry during the first 15 s of the crossing.

3

Space for working and answer

- (ii) Determine the distance travelled by the ferry in the first 30 s of the crossing.

3

Space for working and answer



1. (continued)

- (c) During this crossing a strong current of 2.6 m s^{-1} flows due South (180) between the islands.

In order to complete the crossing the ferry must steer against the current as shown.

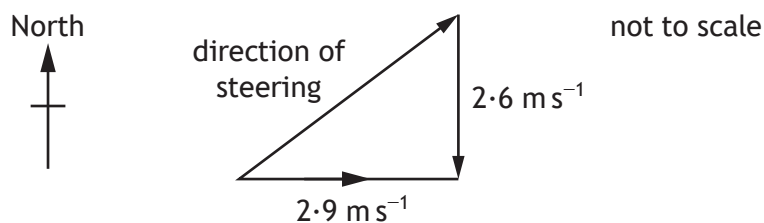

By scale diagram or otherwise, determine the direction the ferry must steer in order to travel directly between port A and B.

2

Space for working and answer

[Turn over



2. A student sets up an experiment using a linear air track as shown.

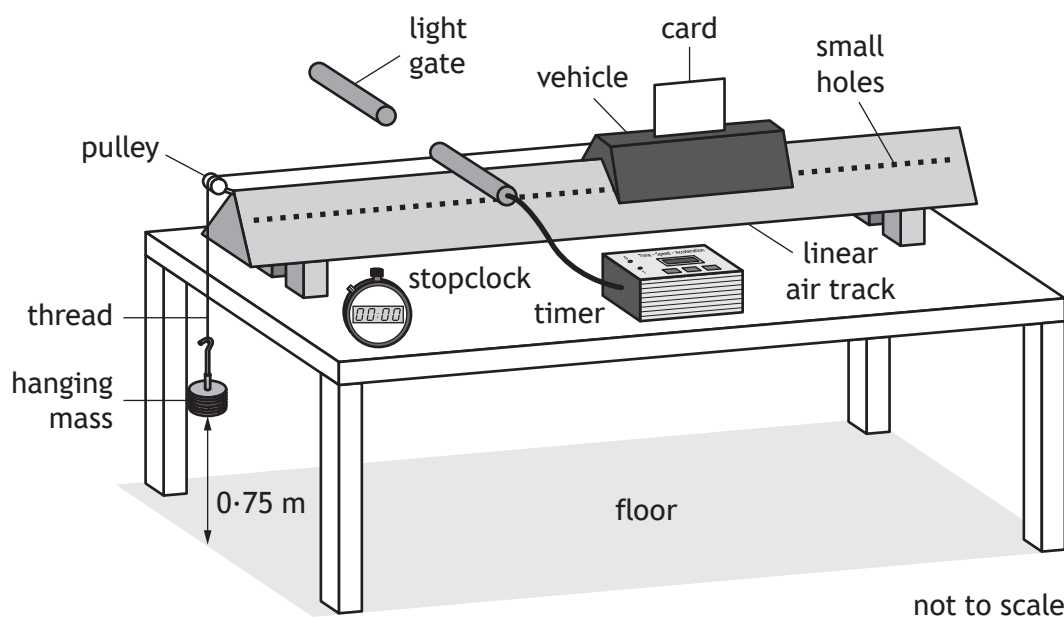

A vehicle is mounted on the track.

Air is blown into the track and out through small holes in the sides of the track, causing the vehicle to be lifted slightly above the track.

The vehicle is released from rest and the card mounted on it passes through the light gate.

(a) (i) Explain the purpose of using air to lift the vehicle slightly above the track.

1

(ii) State the measurements the student must make in this experiment to determine the acceleration of the vehicle.

3



2. (continued)

- (b) The student carries out the experiment using a range of hanging masses. The results are shown in the table.

Mass of hanging mass (kg)	Weight of hanging mass (N)	Acceleration of vehicle (m s^{-2})
0.02	0.20	0.40
0.04	0.39	0.79
0.06	0.59	1.21
0.08	0.78	1.80
0.10	0.98	2.01

The student identifies that one of their values of acceleration needs to be measured again.

State which value of acceleration needs to be measured again.

Justify your answer.

2

- (c) State the main energy change that takes place as the hanging mass falls to the floor.

1

[Turn over



* X 8 5 7 7 5 0 1 0 9 *

3. An athlete is training on a rowing machine. Each movement back and forward on the machine is known as a stroke. The display unit on the machine shows data about the training session.

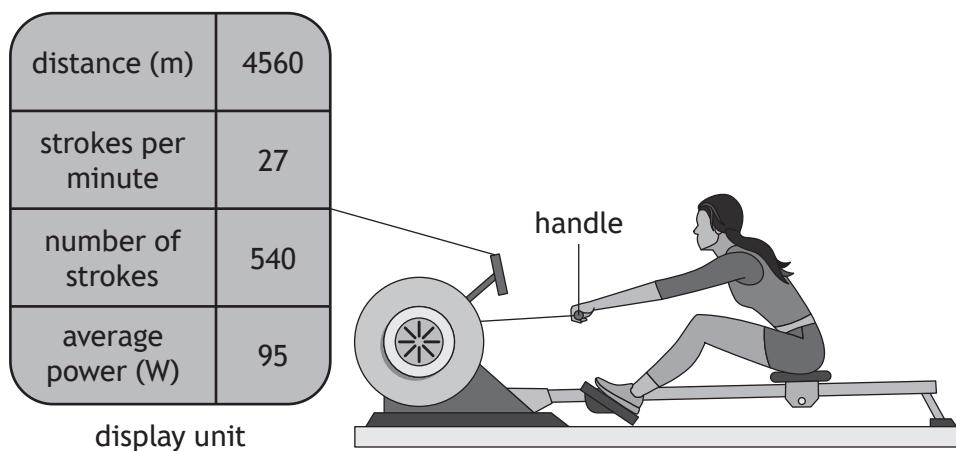

- (a) Show that the frequency of the strokes is 0.45 Hz. 2
Space for working and answer

- (b) (i) The athlete trains for 1200 s. Calculate the energy transferred to the machine by the athlete during this time. 3
Space for working and answer



3. (b) (continued)

(ii) Explain why, during this time, the athlete produces more energy than that calculated in (b) (i).

1

(c) During a stroke, the athlete pulls the handle backward through a distance of 1.3 m.

This movement transfers 208 J of energy to the rowing machine.

Calculate the average force exerted on the handle by the athlete during this movement.

3

Space for working and answer

[Turn over



* X 8 5 7 7 5 0 1 1 1 *

4. The table shows information about the moons of the dwarf planet Pluto.

Name	Mass (kg)	Orbital period (days)	Approximate diameter (km)
Charon	1.6×10^{21}	6.39	1200
Nix	5.0×10^{16}	24.9	50
Hydra	5.0×10^{16}	38.2	51
Kerberos	1.6×10^{16}	32.2	19
Styx	7.5×10^{15}	20.2	16

(a) State what is meant by the term *moon*. 1

(b) State which of these moons orbits at the greatest distance from Pluto. Justify your answer. 2

(c) On its journey to Pluto, the space probe New Horizons passed close by the planet Jupiter. 2
 Explain how passing close to Jupiter reduced the journey time to Pluto.



4. (continued)

- (d) After passing Jupiter, New Horizons was travelling at a speed of 23.0 km s^{-1} .

The mass of New Horizons at this time was 454 kg.

- (i) Calculate the kinetic energy of New Horizons at this time.

3

Space for working and answer

- (ii) New Horizons maintained this speed as it travelled on towards Pluto.

Explain, in terms of forces, why New Horizons did not have to use any fuel in order to maintain this speed.

2

- (e) When it reached Pluto, radio signals sent from New Horizons took 4.4 hours to reach Earth.

Determine the distance travelled by the signals.

3

Space for working and answer



* X 8 5 7 7 5 0 1 1 3 *

5. The Andromeda Galaxy is more than 2 million light-years from Earth and is visible with the naked eye. However, there are many astronomical objects that are not visible with the naked eye.

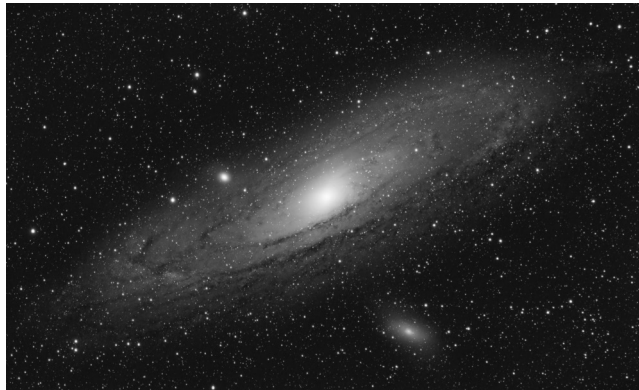

Andromeda Galaxy

Using your knowledge of physics, comment on how astronomers obtain information about astronomical objects.

3



* X 8 5 7 7 5 0 1 1 4 *

DO NOT
WRITE IN
THIS
MARGIN

5. (continued)



* X 8 5 7 7 5 0 1 1 5 *

6. An LED strip is a long strip of plastic with red, green and blue LEDs placed at regular intervals.

The circuit for one group of LEDs is shown.

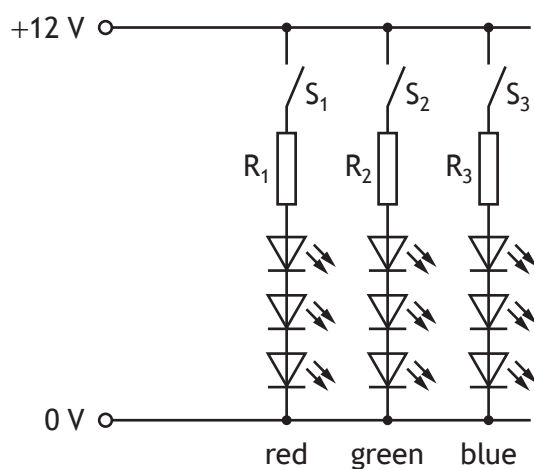

- (a) Switch S_1 is closed and the red LEDs light.

Each red LED operates at a voltage of 1.8 V and a current of 0.020 A.

- (i) State the purpose of the resistor connected in series with the LEDs. 1

- (ii) Determine the resistance of resistor R_1 . 4

Space for working and answer



6. (a) (continued)

(iii) Resistors R_1 , R_2 and R_3 have different resistances.

Suggest a reason why different coloured LEDs require different resistances connected in series.

1

(b) All three switches are now closed.

State whether the red LEDs will be brighter, dimmer or the same brightness compared to when only S_1 is closed.

You must justify your answer.

2

[Turn over



* X 8 5 7 7 5 0 1 1 7 *

7. A security floodlight is used to automatically illuminate an area outside a building when it gets dark.

The circuit for this system is shown.

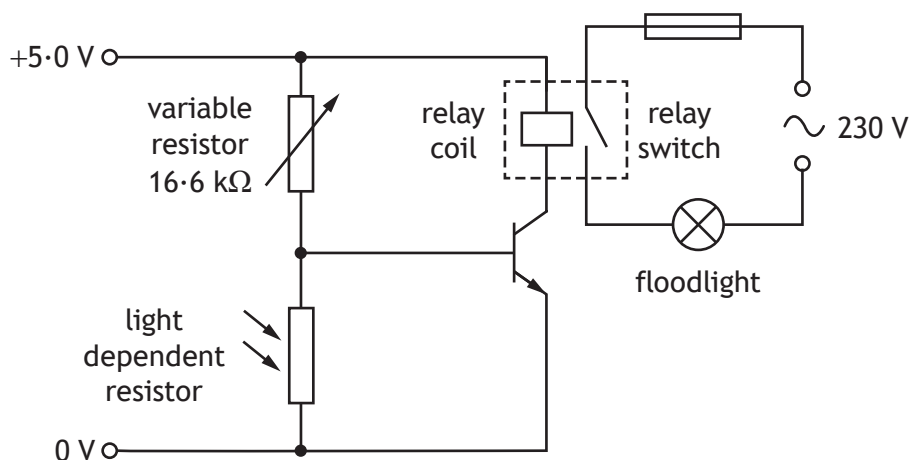

The resistance of the variable resistor is set to $16.6 \text{ k}\Omega$.

The transistor in this circuit has a switch on voltage of 0.7 V .

- (a) The light level decreases to the point where the resistance of the light dependent resistor is $3.4 \text{ k}\Omega$.

Show by calculation that the transistor is switched on at this light level.

3

Space for working and answer



* X 8 5 7 7 5 0 1 1 8 *

7. (continued)

(b) The floodlight is connected in a part of the circuit controlled by a relay.

(i) Explain why a relay is used in the circuit.

1

(ii) The floodlight has a power rating of 575 W.

Calculate the current in the floodlight when it is switched on.

3

Space for working and answer

(iii) The following fuses are available for use with the floodlight.

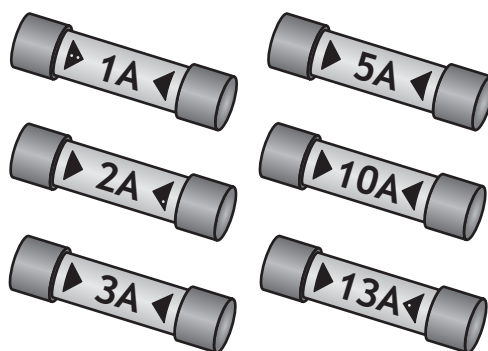

State which of these fuses is the most appropriate for use with the floodlight.

1

[Turn over



8. A storage heater heats a material overnight then allows the material to radiate this heat during the day.

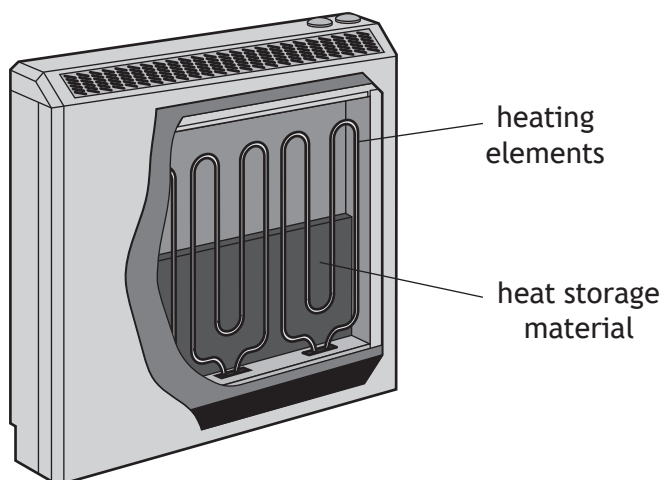

A manufacturer is testing heat storage materials with different specific heat capacities.

In each test the temperature of 2.5 kg of material is raised from 22 °C to 250 °C.

- (a) One of the materials being tested by the manufacturer is clay brick.

Clay brick has a specific heat capacity of $810 \text{ J kg}^{-1} \text{ }^\circ\text{C}^{-1}$.

Calculate the minimum energy required to heat 2.5 kg of clay brick from 22 °C to 250 °C.

3

Space for working and answer



8. (continued)

MARKS
DO NOT
WRITE IN
THIS
MARGIN

(b) The circuit for the heating elements in the storage heater is shown.

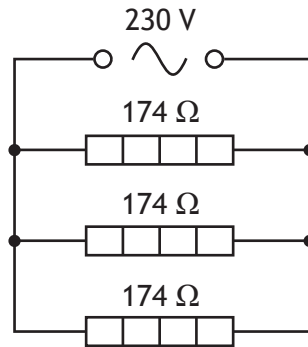

(i) Calculate the total resistance of the circuit.

3

Space for working and answer

(ii) Calculate the total power developed in the circuit.

3

Space for working and answer

(c) The manufacturer repeats the test using oil instead of clay brick.

State whether the time taken to heat the oil is less than, equal to or greater than the time to heat the clay brick.

Justify your answer.

2



9. A scuba diver uses compressed air from a cylinder to breathe underwater.



- (a) When the cylinder is full, the volume of compressed air in the cylinder is equivalent to 960 litres of air at a pressure of 2.5×10^5 Pa.

The cylinder has a fixed volume of 12 litres.

Show that the pressure inside a full cylinder is 2.0×10^7 Pa.

2

Space for working and answer



* X 8 5 7 7 5 0 1 2 2 *

9. (continued)

- (b) A full cylinder containing air at a pressure of 2.0×10^7 Pa is stored at a temperature of 21 °C before the dive.

When the cylinder is submerged in the water, the temperature of the air in the cylinder reduces to the temperature of the water.

This causes the pressure of the air in the full cylinder to reduce to 1.9×10^7 Pa.

- (i) Calculate the temperature of the water.

3

Space for working and answer

- (ii) Using the kinetic model, explain why the pressure of the gas inside the full cylinder decreases as the temperature decreases.

3

[Turn over



* X 8 5 7 7 5 0 1 2 3 *

10. Electric vehicles are being promoted as an environmentally friendly method of transport.



Currently one of the limitations of electric vehicles is their range. The range is the maximum distance that an electric vehicle can travel before its batteries need to be recharged.

Using your knowledge of physics comment on possible factors affecting the range of an electric vehicle.

3



MARKS

DO NOT
WRITE IN
THIS
MARGIN

10. (continued)



* X 8 5 7 7 5 0 1 2 5 *

[BLANK PAGE]

DO NOT WRITE ON THIS PAGE



* X 8 5 7 7 5 0 1 2 6 *

11. A student investigating sound cuts a drinking straw as shown.



(a) The student blows through the straw to produce a sound.

A microphone is connected to an oscilloscope. The oscilloscope displays a trace of the sound wave produced by the straw as shown.

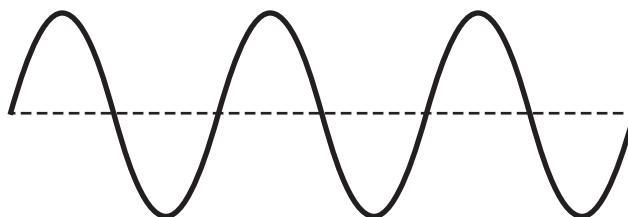

On the trace, draw **and** label

- (i) the amplitude 1
- (ii) the wavelength, λ . 1

(An additional diagram, if required, can be found on *page 35*.)

(b) The sound produced has a frequency of 250 Hz.
 Calculate the wavelength of the sound in air. 3
Space for working and answer

[Turn over



11. (continued)

- (c) The student carries out an experiment to investigate how the length of the straw affects the frequency of the sound produced.

The results of this experiment are as shown.

Length of straw (mm)	Frequency (Hz)
20	1204
40	597
60	420
80	282
100	250

- (i) Using the graph paper below, draw a graph of these results.
 (Additional graph paper, if required, can be found on *page 35*.)

3

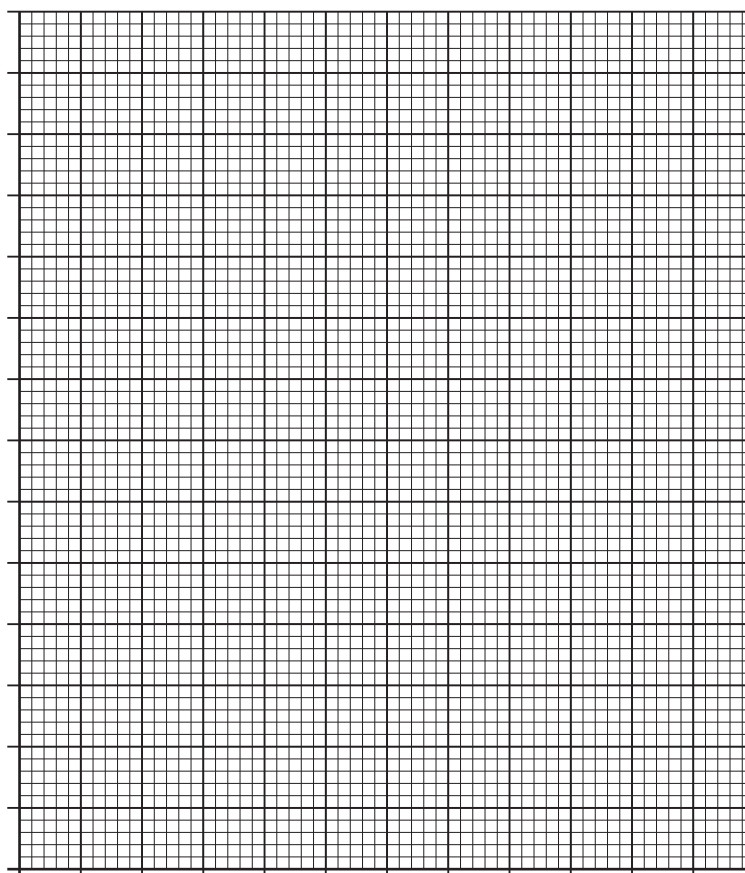

MARKS

DO NOT
WRITE IN
THIS
MARGIN

11. (c) (continued)

(ii) Use your graph to predict the frequency of sound produced by a straw that is 30 mm in length.

1

(iii) Suggest one change that could be made to improve the reliability of this experiment.

1

[Turn over



* X 8 5 7 7 5 0 1 2 9 *

12. A scientist studying human genetics uses a technique involving a radioactive tracer called a DNA probe.

The DNA probe allows the scientist to identify if a particular section of DNA is present within a sample of tissue.

- (a) The scientist prepares a solution containing the DNA probe and labels it as shown.

DNA Probe Solution
Date prepared: Monday 20 April 2020
Half-life: 22 hours
Radiation emitted: Beta particles

Suggest why this solution would be unsuitable to use one week after it was prepared.

1

- (b) The scientist uses the equipment shown to test a tissue sample to identify if the DNA probe is present.

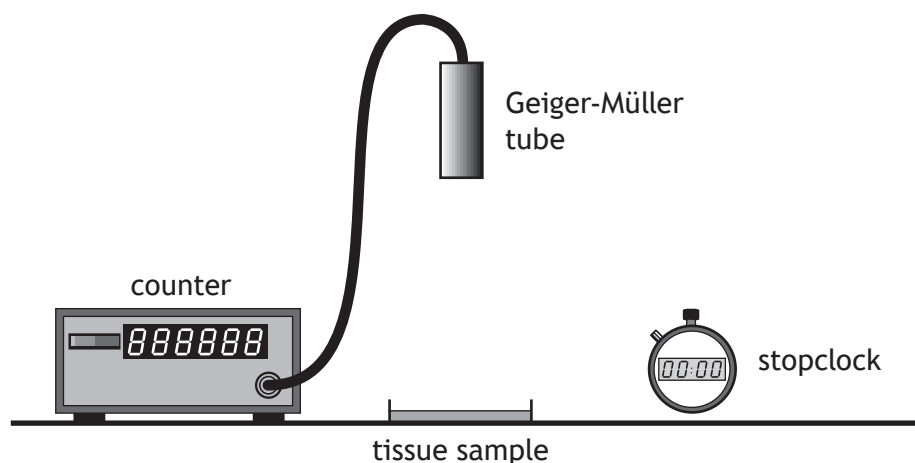

The average background count rate is 18 counts per minute.



12. (b) (continued)

(i) State a source of background radiation.

1

(ii) The tissue sample has an activity of 5.5 Bq.

Calculate the number of decays that occur in this sample each minute.

3

Space for working and answer

(iii) In practice, the number of decays per minute detected by the Geiger-Müller tube is much less than the number of decays calculated in (b) (ii).

This makes it difficult to distinguish the count rate due to the DNA probe from that due to background radiation.

Suggest one change to the set up that would increase the number of decays per minute detected by the Geiger-Müller tube due to the DNA probe in this sample.

1

[Turn over



* X 8 5 7 7 5 0 1 3 1 *

13. In a nuclear power station, nuclear reactions are used to generate electrical energy.



- (a) In a nuclear reaction a uranium nucleus is split by a neutron to produce two smaller nuclei, two or three neutrons and energy.
- (i) State the name given to this type of nuclear reaction. 1
- (ii) Explain how a single reaction can lead to the continuous generation of energy. 2



13. (continued)

MARKS

DO NOT
WRITE IN
THIS
MARGIN

- (b) The waste products from nuclear power stations are radioactive and need to be stored until their activity reaches a safe level.

One type of waste has a half-life of 32 years.

Determine the time taken for the activity of this waste to decrease to one eighth of its original value.

3

Space for working and answer

- (c) During a typical shift, a worker handling radioactive material receives an absorbed dose of $2.2 \mu\text{Gy}$ from slow neutrons and $3.4 \mu\text{Gy}$ from gamma radiation.

- (i) Determine the total equivalent dose received by the worker during a typical shift.

4

Space for working and answer

- (ii) The annual dose limit for a radiation worker is 20 mSv.

Determine the number of typical shifts that it would take for the worker to receive a dose of 20 mSv.

2

Space for working and answer

[END OF QUESTION PAPER]



* X 8 5 7 7 5 0 1 3 3 *

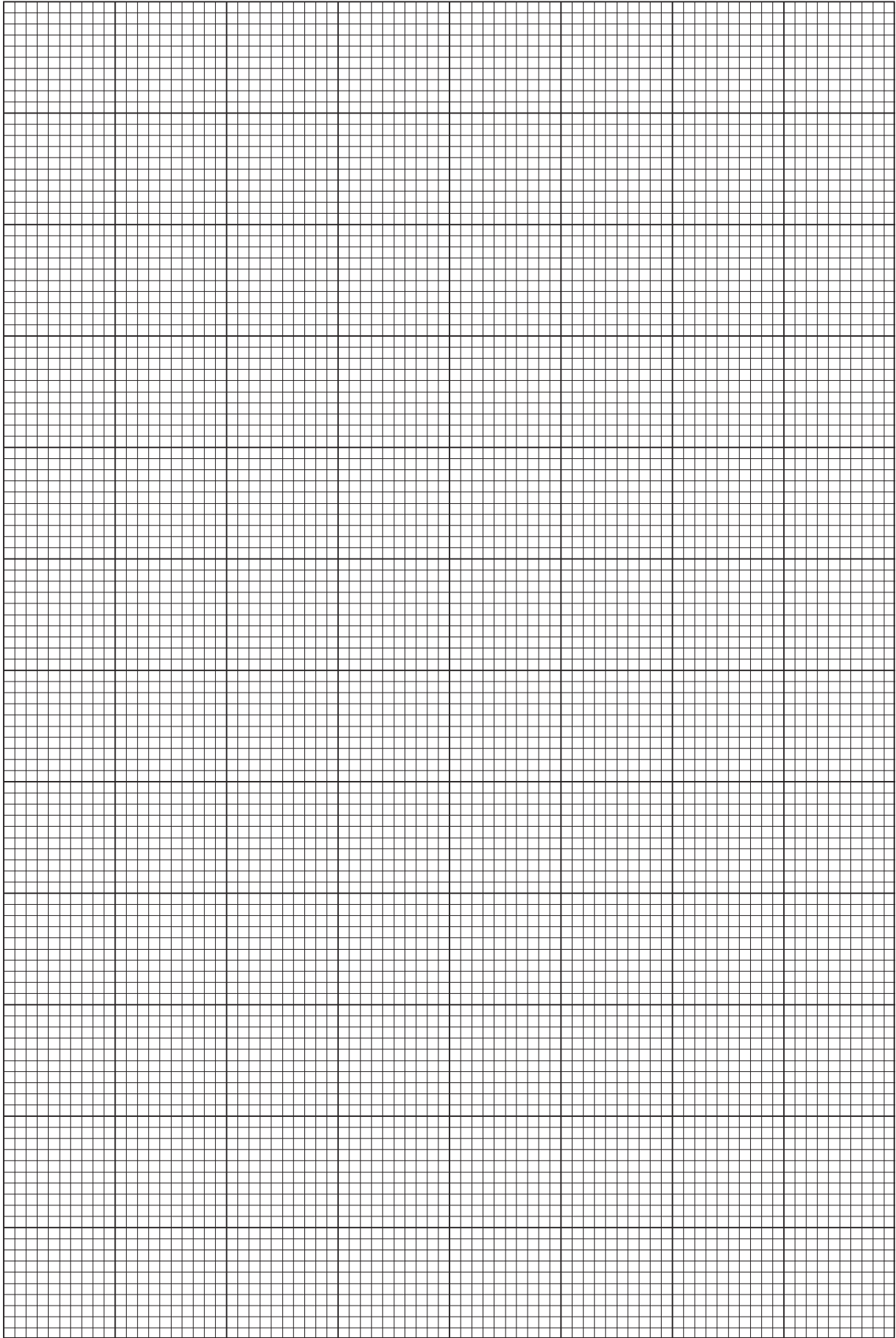

* X 8 5 7 7 5 0 1 3 4 *

ADDITIONAL SPACE FOR ANSWERS AND ROUGH WORK

Additional diagram for question 11 (a)

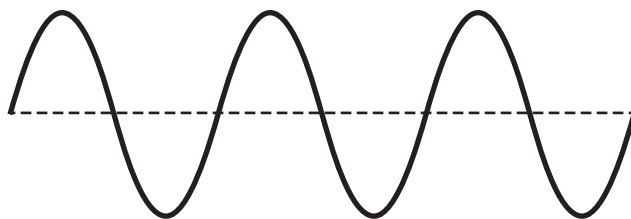

Additional graph paper for question 11 (c) (i)

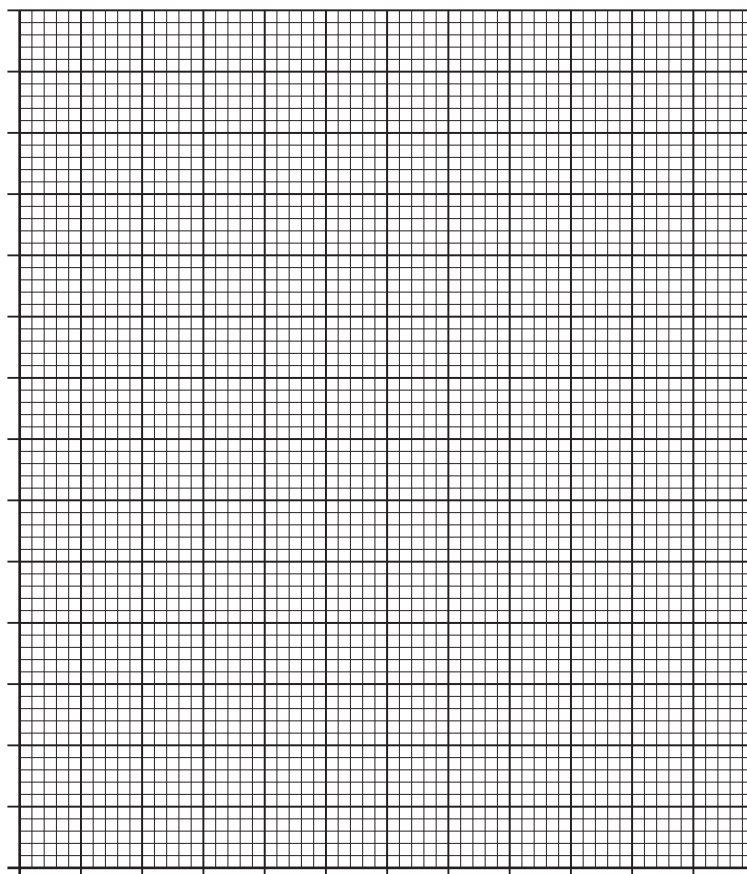

MARKS

DO NOT
WRITE IN
THIS
MARGIN

ADDITIONAL SPACE FOR ANSWERS AND ROUGH WORK



* X 8 5 7 7 5 0 1 3 6 *

MARKS

DO NOT
WRITE IN
THIS
MARGIN

ADDITIONAL SPACE FOR ANSWERS AND ROUGH WORK



* X 8 5 7 7 5 0 1 3 7 *

[BLANK PAGE]

DO NOT WRITE ON THIS PAGE



* X 8 5 7 7 5 0 1 3 8 *

[BLANK PAGE]

DO NOT WRITE ON THIS PAGE



* X 8 5 7 7 5 0 1 3 9 *

[BLANK PAGE]

DO NOT WRITE ON THIS PAGE

Acknowledgement of copyright

- Question 3 colonga123456/shutterstock.com
- Question 5 drivingcat/shutterstock.com
- Question 9 Natali Snailcat/shutterstock.com
- Question 10 Ververidis Vasilis/shutterstock.com
- Question 13 SpaceKris/shutterstock.com



* X 8 5 7 7 5 0 1 4 0 *