



National
Qualifications
2024

X857/75/02

Physics
Section 1 — Questions

THURSDAY, 25 APRIL

1:00 PM – 3:30 PM

Instructions for the completion of Section 1 are given on *page 02* of your question and answer booklet X857/75/01.

Record your answers on the answer grid on *page 03* of your question and answer booklet.

Reference may be made to the data sheet on *page 02* of this booklet and to the relationships sheet X857/75/11.

Before leaving the examination room you must give your question and answer booklet to the Invigilator; if you do not, you may lose all the marks for this paper.



* X 8 5 7 7 5 0 2 *

DATA SHEET

Speed of light in materials

Material	Speed in m s^{-1}
Air	3.0×10^8
Carbon dioxide	3.0×10^8
Diamond	1.2×10^8
Glass	2.0×10^8
Glycerol	2.1×10^8
Water	2.3×10^8

Gravitational field strengths

	Gravitational field strength on the surface in N kg^{-1}
Earth	9.8
Jupiter	23
Mars	3.7
Mercury	3.7
Moon	1.6
Neptune	11
Saturn	9.0
Sun	270
Uranus	8.7
Venus	8.9

Specific latent heat of fusion of materials

Material	Specific latent heat of fusion in J kg^{-1}
Alcohol	0.99×10^5
Aluminium	3.95×10^5
Carbon dioxide	1.80×10^5
Copper	2.05×10^5
Iron	2.67×10^5
Lead	0.25×10^5
Water	3.34×10^5

Specific latent heat of vaporisation of materials

Material	Specific latent heat of vaporisation in J kg^{-1}
Alcohol	11.2×10^5
Carbon dioxide	3.77×10^5
Glycerol	8.30×10^5
Turpentine	2.90×10^5
Water	22.6×10^5

Speed of sound in materials

Material	Speed in m s^{-1}
Aluminium	5200
Air	340
Bone	4100
Carbon dioxide	270
Glycerol	1900
Muscle	1600
Steel	5200
Tissue	1500
Water	1500

Specific heat capacity of materials

Material	Specific heat capacity in $\text{J kg}^{-1} \text{ } ^\circ\text{C}^{-1}$
Alcohol	2350
Aluminium	902
Copper	386
Glass	500
Ice	2100
Iron	480
Lead	128
Oil	2130
Water	4180

Melting and boiling points of materials

Material	Melting point in $^\circ\text{C}$	Boiling point in $^\circ\text{C}$
Alcohol	-98	65
Aluminium	660	2470
Copper	1077	2567
Lead	328	1737
Iron	1537	2737
Water	-	100

Radiation weighting factors

Type of radiation	Radiation weighting factor
alpha	20
beta	1
fast neutrons	10
gamma	1
slow neutrons	3
X-rays	1

SECTION 1 — 25 marks

Attempt ALL questions

1. Which row in the table classifies speed, weight, and energy correctly?

	Speed	Weight	Energy
A	scalar	scalar	scalar
B	vector	scalar	vector
C	scalar	vector	vector
D	vector	vector	vector
E	scalar	vector	scalar

2. A student uses the apparatus shown to determine the average speed and instantaneous speed of a trolley as it travels down a slope.

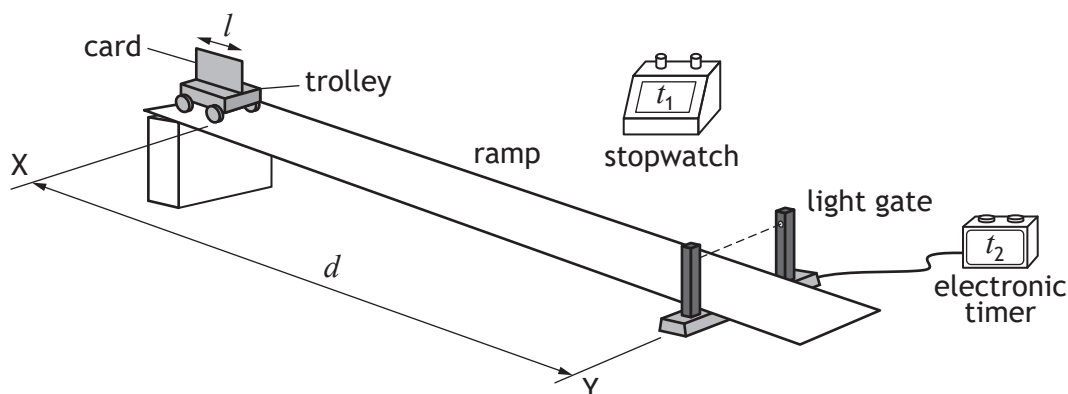

The trolley is released at X and travels down the slope.

The distance between X and the light gate at Y is d .

The time taken for the trolley to reach the light gate is t_1 .

The length of the card on the trolley is l .

The time taken for the card to pass through the light gate is t_2 .

Which row in the table shows the measurements required to determine the average speed of the trolley between X and Y, and the instantaneous speed of the trolley at Y?

	Measurements for average speed between X and Y	Measurements for instantaneous speed at Y
A	l and t_1	d and t_2
B	d and t_1	l and t_2
C	l and t_2	d and t_1
D	d and t_2	l and t_2
E	d and t_1	l and t_1

3. A rocket is taking off from the surface of the Earth. The rocket engines exert a force on the exhaust gases.

Which of the following is the reaction to this force?

- A The force of the Earth on the exhaust gases.
 - B The force of the Earth on the rocket engines.
 - C The force of the rocket engines on the Earth.
 - D The force of the exhaust gases on the Earth.
 - E The force of the exhaust gases on the rocket engines.
4. A motor raises a mass of 2400 kg vertically through a height of 5.0 m in 2 minutes.
The minimum power rating of the motor to raise the mass is
- A 100 W
 - B 980 W
 - C 24 000 W
 - D 59 000 W
 - E 120 000 W.
5. A satellite is in circular orbit around a planet.

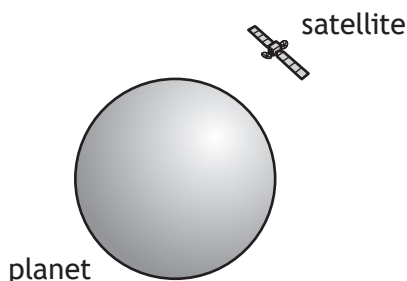

A group of students make the following statements about the satellite in orbit:

- I The horizontal speed of the satellite is constant.
- II The satellite does not move.
- III While orbiting the planet the satellite is weightless.

Which of these statements is/are correct?

- A I only
- B II only
- C III only
- D I and III only
- E II and III only

6. A pulse of light from a laser is transmitted from the Earth to the Moon.

The light reflects from a mirror on the Moon and is detected back on Earth 2.6 s after being transmitted.

The distance from the Earth to the Moon is

- A 8.8×10^2 m
 - B 1.2×10^8 m
 - C 2.3×10^8 m
 - D 3.9×10^8 m
 - E 7.8×10^8 m.
7. The table shows the altitude and period of four satellites.

Satellite	Altitude (km)	Period (minutes)
International Space Station	408	93
AprizeSat-3	686	
Intelsat-18	35 800	1440
Hubble Space Telescope	537	95

The period of the AprizeSat-3 satellite is

- A 85 minutes
 - B 94 minutes
 - C 98 minutes
 - D 1440 minutes
 - E 1600 minutes.
8. A student makes the following statements about the Universe:
- I One light-year is the time taken for light to travel from the Sun to the Earth.
 - II The approximate age of the Universe is 13.8 billion years.
 - III The 'Big Bang' theory describes the origin of the Universe.

Which of these statements is/are correct?

- A II only
- B III only
- C I and III only
- D II and III only
- E I, II and III

9. An electric field exists around two point charges Q and R. The diagram shows the path taken by a charged particle as it travels through the field. The motion of the particle is as shown.

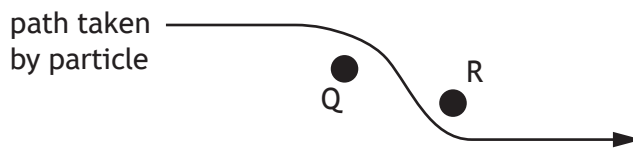

Which row in the table identifies the charge on the particle, the charge on Q, and the charge on R?

	Charge on particle	Charge on Q	Charge on R
A	positive	negative	negative
B	negative	negative	positive
C	negative	positive	negative
D	positive	negative	positive
E	positive	positive	positive

10. A toaster is connected to a 230 V mains supply and switched on. The heating element in the toaster has a power rating of 1.2 kW. A student makes the following statements about the toaster:
- I The heating element transfers 12 000 J of electrical energy each second.
 - II The plug of the toaster should be fitted with a fuse rated at 13 A.
 - III The charge passing through the heating element each second is 230 C.

Which of these statements is/are correct?

- A I only
- B II only
- C I and II only
- D II and III only
- E I, II and III

11. A circuit is set up as shown.

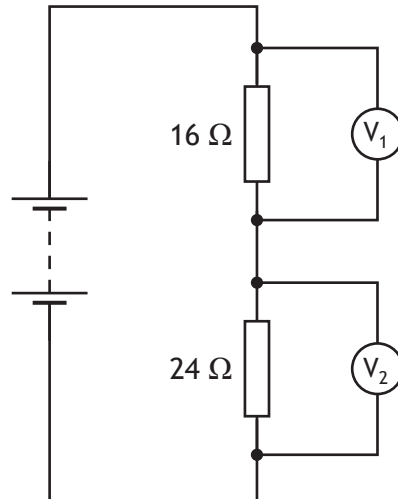

The reading on voltmeter V_1 is 3.6 V.

The reading on voltmeter V_2 is

- A 0.4 V
- B 2.2 V
- C 2.4 V
- D 3.6 V
- E 5.4 V.

[Turn over

12. A circuit is set up as shown.

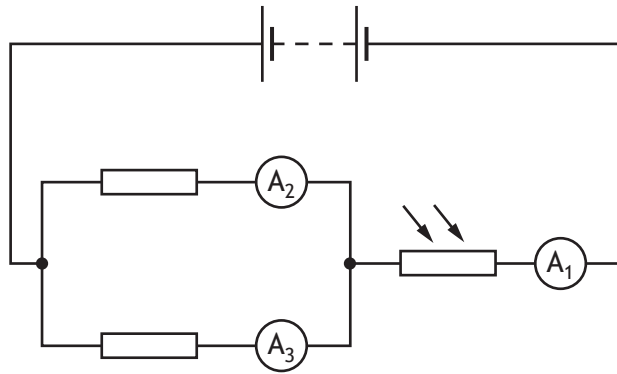

The resistance of the LDR increases as the light level decreases.

The light level incident on the LDR decreases.

Which row in the table describes the effect of this change on the readings on the ammeters?

	Reading on ammeter A_1	Reading on ammeter A_2	Reading on ammeter A_3
A	decreases	decreases	decreases
B	decreases	stays the same	stays the same
C	stays the same	stays the same	stays the same
D	increases	stays the same	stays the same
E	increases	increases	increases

13. Three resistors are connected as shown.

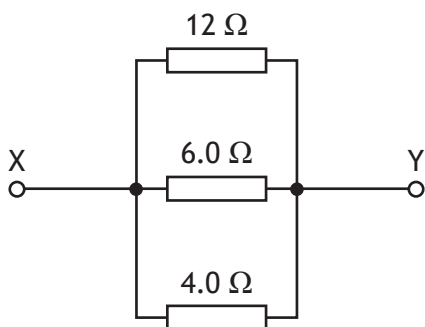

The total resistance between X and Y is

- A 0.5 Ω
- B 2.0 Ω
- C 4.0 Ω
- D 6.0 Ω
- E 22 Ω .

14. A length of wire has a resistance of 8.0Ω .

The current in the wire is 1.5 A .

The power developed in the wire is

- A 5.3 W
- B 12 W
- C 18 W
- D 43 W
- E 96 W .

15. A student carries out an experiment to determine the specific heat capacity of copper.

The setup used by the student is shown.

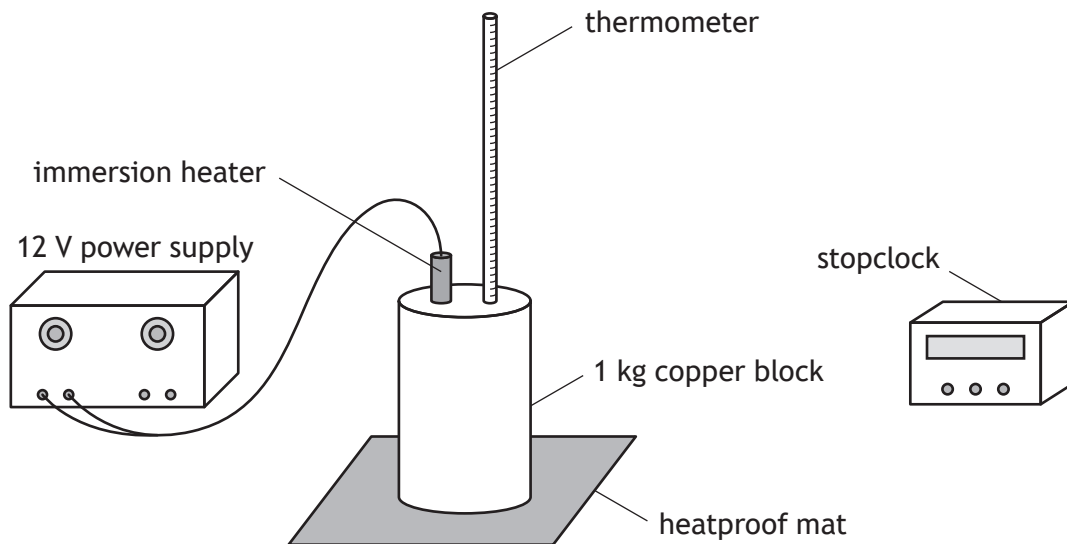

The student heats the copper block for 5 minutes.

The temperature of the block increases by $14 \text{ }^\circ\text{C}$.

The value of the specific heat capacity of copper determined by the student using this method is found to be inaccurate.

Which of the following changes would improve the accuracy of this experiment?

- A Heating the copper block for a longer time.
- B Placing insulation around the copper block.
- C Replacing the copper block with one of less mass.
- D Replacing the immersion heater with one of a higher power rating.
- E Removing the heatproof mat.

[Turn over

16. A solid substance is placed in an insulated container and heated.
The graph shows how the temperature T of the substance varies with time t .

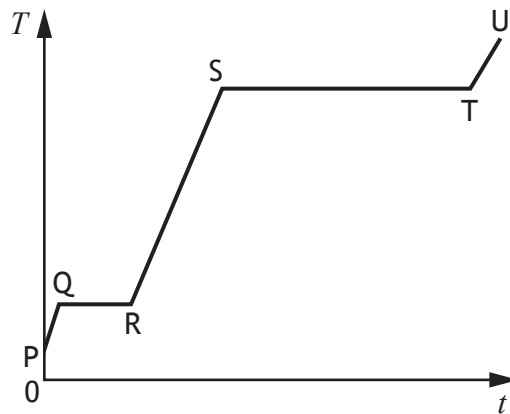

To determine the specific latent heat of vaporisation of the substance, a student would use the time from section

- A PQ
 - B QR
 - C RS
 - D ST
 - E TU.
17. A syringe containing air is sealed at one end as shown.

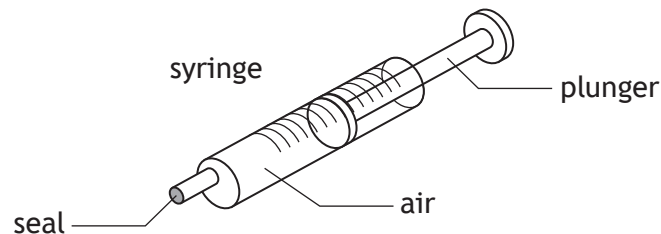

The initial volume of the air in the syringe is $1.40 \times 10^{-6} \text{ m}^3$ and the pressure is 120 kPa.
The plunger is pushed in causing the volume to be **reduced by** $0.30 \times 10^{-6} \text{ m}^3$.
The temperature of the air inside the syringe remains constant.
The pressure of the air inside the syringe is now

- A 26 kPa
- B 94 kPa
- C 99 kPa
- D 153 kPa
- E 560 kPa.

18. The size of the buoyancy force F_b acting on an object immersed in a fluid is given by the relationship

$$F_b = \rho g V$$

where: ρ is the density of the fluid in kg m^{-3}

g is the gravitational field strength in N kg^{-1}

V is the volume of the object in m^3 .

The volume of an object that experiences a buoyancy force of 360 N when immersed in a fluid of density 1020 kg m^{-3} is

- A 0.036 m^3
B 0.33 m^3
C 3.5 m^3
D 28 m^3
E 37 000 m^3 .
19. The diagram represents a wave travelling from X to Y.

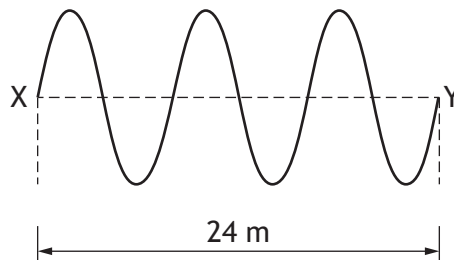

The speed of the wave is 48 m s^{-1} .

The frequency of the wave is

- A 0.50 Hz
B 2.0 Hz
C 6.0 Hz
D 144 Hz
E 384 Hz.

[Turn over

20. The letters X, Y, and Z represent missing words or phrases from the following passage.

Infrared has aX.... wavelength than visible light.

Infrared diffractsY.... than visible light.

The speed of infrared isZ.... visible light.

Which row in the table shows the missing words or phrases?

	X	Y	Z
A	longer	less	the same as
B	shorter	less	slower than
C	longer	more	the same as
D	shorter	more	faster than
E	longer	more	faster than

21. The diagram shows the path of a ray of red light as it passes through and out of a semicircular glass block.

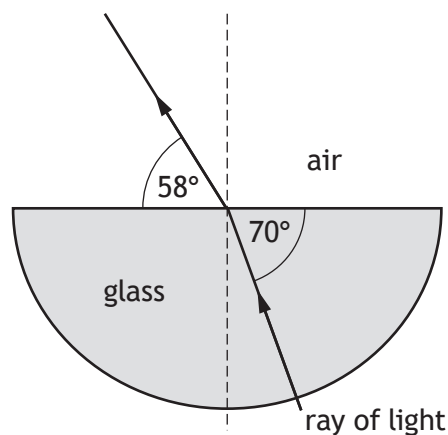

Which row in the table shows the angle of incidence in the glass and the angle of refraction in air?

	Angle of incidence in glass	Angle of refraction in air
A	20°	32°
B	32°	20°
C	58°	70°
D	70°	32°
E	70°	58°

22. Which of the following statements describes the term *ionisation*?
- A The removal of a proton from an atom to form a charged particle.
 - B The removal of an electron from an atom to form a charged particle.
 - C The removal of a neutron from an atom.
 - D The splitting of a large nucleus into smaller nuclei.
 - E The joining of small nuclei to form a larger nucleus.
23. In a radioactive source 1.8×10^6 nuclei decay in 10 hours.
The activity of the source is
- A 1.8×10^5 Bq
 - B 3.0×10^4 Bq
 - C 3.0×10^3 Bq
 - D 500 Bq
 - E 50 Bq.
24. A sample of tissue receives an absorbed dose of $0.20 \mu\text{Gy}$ from a source of alpha radiation and an absorbed dose of $6.0 \mu\text{Gy}$ from a source of slow neutrons.
The total equivalent dose received by the sample of tissue is
- A $6.2 \mu\text{Sv}$
 - B $19 \mu\text{Sv}$
 - C $22 \mu\text{Sv}$
 - D $64 \mu\text{Sv}$
 - E $140 \mu\text{Sv}$.

[Turn over

25. A technician carries out an experiment, using the apparatus shown, to determine the half-life of a radioactive source.

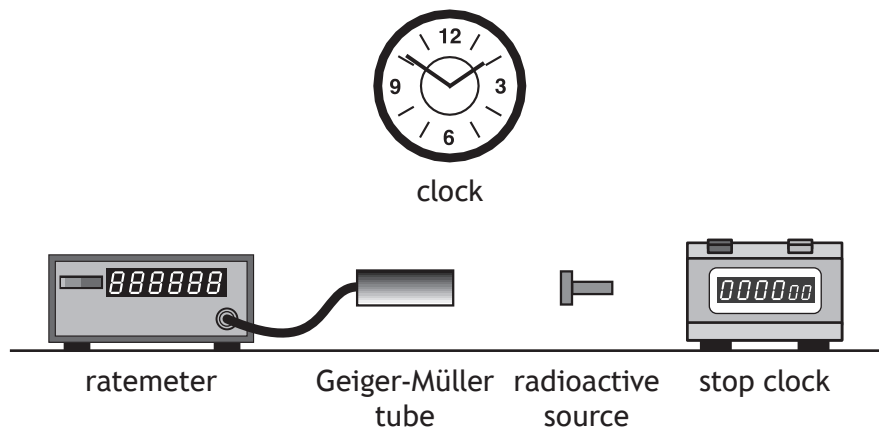

Before carrying out the experiment the technician measures the background count rate.

The technician takes readings of the count rate displayed on the ratemeter every 60 s for a period of 20 minutes.

A graph of the technician's measurements is as shown.

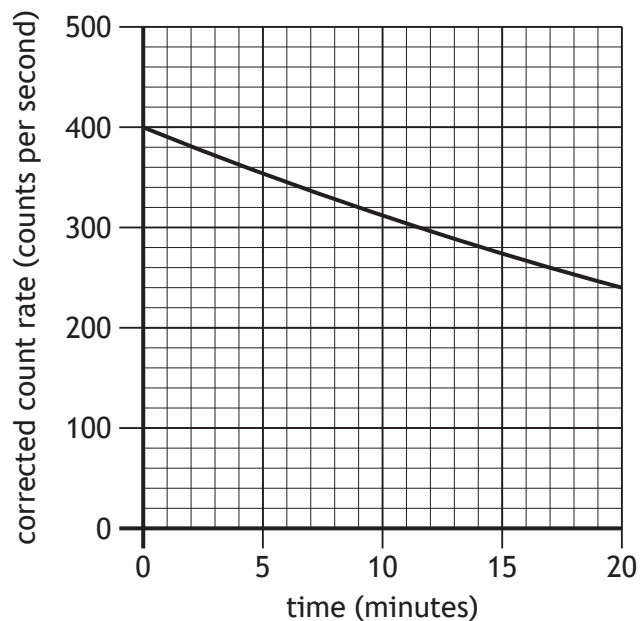

Which of the following changes would allow the technician to more easily determine the half-life of the radioactive source?

- A Take readings of the count rate every 30 seconds for 20 minutes.
- B Take readings of the count rate every 60 seconds for 40 minutes.
- C Place lead shielding around the radioactive source.
- D Move the radioactive source closer to the Geiger-Müller tube.
- E Move the radioactive source further away from the Geiger-Müller tube.

[END OF SECTION 1. NOW ATTEMPT THE QUESTIONS IN SECTION 2 OF YOUR QUESTION AND ANSWER BOOKLET]

[BLANK PAGE]

DO NOT WRITE ON THIS PAGE

[BLANK PAGE]

DO NOT WRITE ON THIS PAGE

FOR OFFICIAL USE



National
Qualifications
2024

Mark

X857/75/01

**Physics
Section 1 — Answer grid
and Section 2**

THURSDAY, 25 APRIL

1:00 PM – 3:30 PM



* X 8 5 7 7 5 0 1 *

Fill in these boxes and read what is printed below.

Full name of centre

Town

Forename(s)

Surname

Number of seat

Date of birth

Day

Month

Year

Scottish candidate number

Total marks — 135

SECTION 1 — 25 marks

Attempt ALL questions.

Instructions for completion of Section 1 are given on *page 02*.

SECTION 2 — 110 marks

Attempt ALL questions.

Reference may be made to the data sheet on *page 02* of the question paper X857/75/02 and to the relationships sheet X857/75/11.

Write your answers clearly in the spaces provided in this booklet. Additional space for answers and rough work is provided at the end of this booklet. If you use this space you must clearly identify the question number you are attempting. Any rough work must be written in this booklet. Score through your rough work when you have written your final copy.

Use **blue** or **black** ink.

Before leaving the examination room you must give this booklet to the Invigilator; if you do not, you may lose all the marks for this paper.



* X 8 5 7 7 5 0 1 0 1 *

SECTION 1 — 25 marks

The questions for Section 1 are contained in the question paper X857/75/02.

Read these and record your answers on the answer grid on *page 03* opposite.

Use **blue** or **black** ink. Do NOT use gel pens or pencil.

1. The answer to each question is **either** A, B, C, D or E. Decide what your answer is, then fill in the appropriate bubble (see sample question below).
2. There is **only one correct** answer to each question.
3. Any rough work must be written in the additional space for answers and rough work at the end of this booklet.

Sample question

The energy unit measured by the electricity meter in your home is the

- A ampere
- B kilowatt-hour
- C watt
- D coulomb
- E volt.

The correct answer is **B** — kilowatt-hour. The answer **B** bubble has been clearly filled in (see below).

A	B	C	D	E
<input type="radio"/>	<input checked="" type="radio"/>	<input type="radio"/>	<input type="radio"/>	<input type="radio"/>

Changing an answer

If you decide to change your answer, cancel your first answer by putting a cross through it (see below) and fill in the answer you want. The answer below has been changed to **D**.

A	B	C	D	E
<input type="radio"/>	<input checked="" type="radio"/>	<input type="radio"/>	<input checked="" type="radio"/>	<input type="radio"/>

If you then decide to change back to an answer you have already scored out, put a tick (✓) to the **right** of the answer you want, as shown below:

A	B	C	D	E	or	A	B	C	D	E
<input type="radio"/>	<input checked="" type="radio"/>	<input type="radio"/>	<input checked="" type="radio"/>	<input type="radio"/>		<input type="radio"/>	<input checked="" type="radio"/>	<input type="radio"/>	<input type="radio"/>	<input type="radio"/>



SECTION 1 — Answer grid



	A	B	C	D	E
1	<input type="radio"/>	<input type="radio"/>	<input type="radio"/>	<input type="radio"/>	<input type="radio"/>
2	<input type="radio"/>	<input type="radio"/>	<input type="radio"/>	<input type="radio"/>	<input type="radio"/>
3	<input type="radio"/>	<input type="radio"/>	<input type="radio"/>	<input type="radio"/>	<input type="radio"/>
4	<input type="radio"/>	<input type="radio"/>	<input type="radio"/>	<input type="radio"/>	<input type="radio"/>
5	<input type="radio"/>	<input type="radio"/>	<input type="radio"/>	<input type="radio"/>	<input type="radio"/>
6	<input type="radio"/>	<input type="radio"/>	<input type="radio"/>	<input type="radio"/>	<input type="radio"/>
7	<input type="radio"/>	<input type="radio"/>	<input type="radio"/>	<input type="radio"/>	<input type="radio"/>
8	<input type="radio"/>	<input type="radio"/>	<input type="radio"/>	<input type="radio"/>	<input type="radio"/>
9	<input type="radio"/>	<input type="radio"/>	<input type="radio"/>	<input type="radio"/>	<input type="radio"/>
10	<input type="radio"/>	<input type="radio"/>	<input type="radio"/>	<input type="radio"/>	<input type="radio"/>
11	<input type="radio"/>	<input type="radio"/>	<input type="radio"/>	<input type="radio"/>	<input type="radio"/>
12	<input type="radio"/>	<input type="radio"/>	<input type="radio"/>	<input type="radio"/>	<input type="radio"/>
13	<input type="radio"/>	<input type="radio"/>	<input type="radio"/>	<input type="radio"/>	<input type="radio"/>
14	<input type="radio"/>	<input type="radio"/>	<input type="radio"/>	<input type="radio"/>	<input type="radio"/>
15	<input type="radio"/>	<input type="radio"/>	<input type="radio"/>	<input type="radio"/>	<input type="radio"/>
16	<input type="radio"/>	<input type="radio"/>	<input type="radio"/>	<input type="radio"/>	<input type="radio"/>
17	<input type="radio"/>	<input type="radio"/>	<input type="radio"/>	<input type="radio"/>	<input type="radio"/>
18	<input type="radio"/>	<input type="radio"/>	<input type="radio"/>	<input type="radio"/>	<input type="radio"/>
19	<input type="radio"/>	<input type="radio"/>	<input type="radio"/>	<input type="radio"/>	<input type="radio"/>
20	<input type="radio"/>	<input type="radio"/>	<input type="radio"/>	<input type="radio"/>	<input type="radio"/>
21	<input type="radio"/>	<input type="radio"/>	<input type="radio"/>	<input type="radio"/>	<input type="radio"/>
22	<input type="radio"/>	<input type="radio"/>	<input type="radio"/>	<input type="radio"/>	<input type="radio"/>
23	<input type="radio"/>	<input type="radio"/>	<input type="radio"/>	<input type="radio"/>	<input type="radio"/>
24	<input type="radio"/>	<input type="radio"/>	<input type="radio"/>	<input type="radio"/>	<input type="radio"/>
25	<input type="radio"/>	<input type="radio"/>	<input type="radio"/>	<input type="radio"/>	<input type="radio"/>



[BLANK PAGE]

DO NOT WRITE ON THIS PAGE



* X 8 5 7 7 5 0 1 0 4 *

[Turn over for SECTION 2

DO NOT WRITE ON THIS PAGE



* X 8 5 7 7 5 0 1 0 5 *

SECTION 2 — 110 marks

Attempt ALL questions

1. The graph represents the motion of a bus travelling along a straight, level road between two stops.

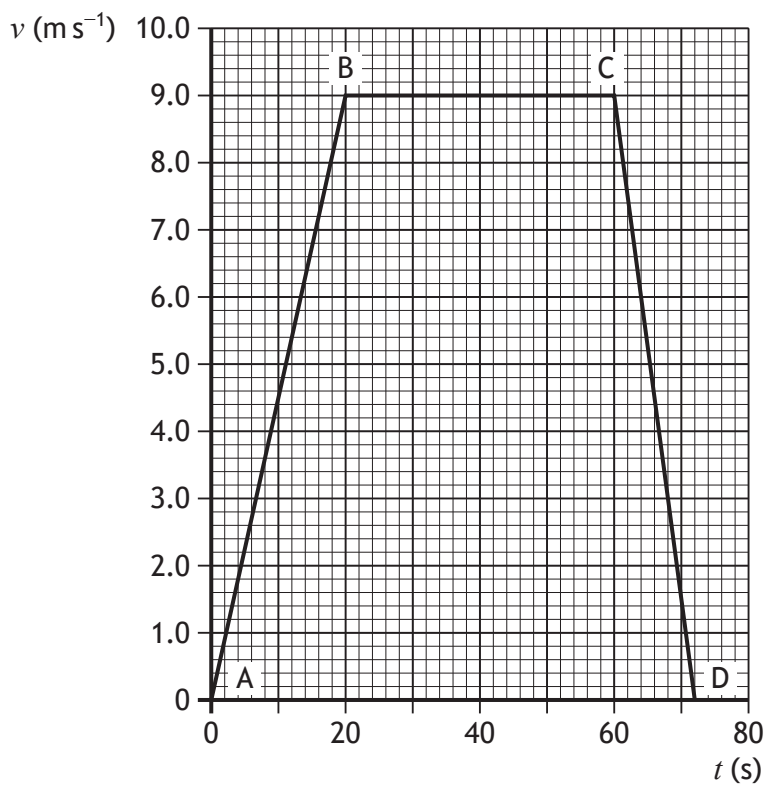

(a) Describe the motion of the bus:

(i) between A and B

1

(ii) between B and C.

1



1. (continued)

(b) Calculate the acceleration of the bus between C and D.

Space for working and answer

3

(c) Determine the distance travelled by the bus between A and D.

Space for working and answer

3

[Turn over



* X 8 5 7 7 5 0 1 0 7 *

2. The triathlon is an endurance race consisting of three stages: swimming, cycling, and running.

(a) The first stage of the triathlon is a 1.5 km open-water swim.

At one point during the swim, the unbalanced forward force on the triathlete is 25 N at a bearing of 090.

At this point, a current exerts a force on the triathlete of 12 N at a bearing of 180.

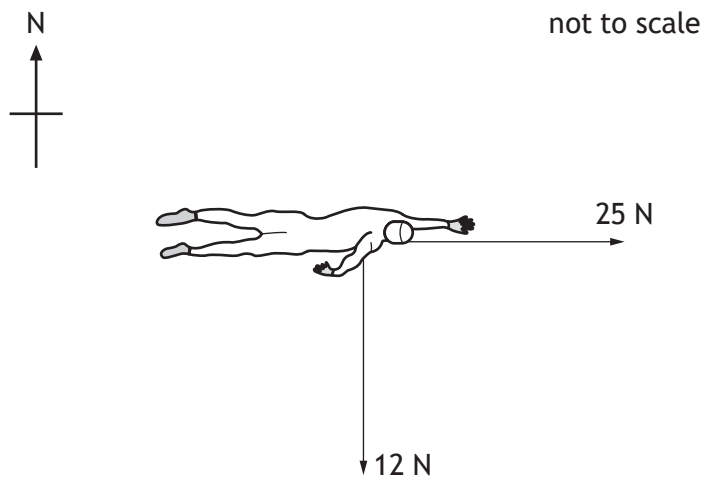

(i) (A) By scale drawing or otherwise, determine the magnitude of the resultant of these forces.

2

Space for working and answer



2. (a) (i) (continued)

(B) By scale drawing or otherwise, determine the direction of the resultant of these forces.

2

Space for working and answer

(ii) The triathlete has a mass of 75 kg.

Calculate the acceleration of the triathlete.

3

Space for working and answer

(b) The second stage of the triathlon is a 40 km cycle.

Suggest one way in which the triathlete could reduce the frictional forces acting against them when cycling.

1

[Turn over



* X 8 5 7 7 5 0 1 0 9 *

2. (continued)

- (c) The third stage of the triathlon involves running four laps of a 2.5 km course. The triathlete takes 38 minutes to complete this stage.

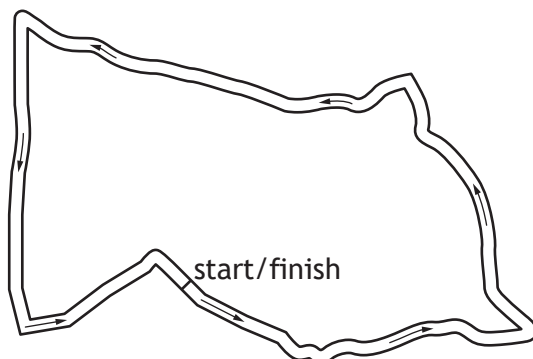

- (i) Determine the average speed of the triathlete for this stage.

3

Space for working and answer

- (ii) State the magnitude of the average velocity of the triathlete for this stage.

1



[Turn over for next question

DO NOT WRITE ON THIS PAGE



* X 8 5 7 7 5 0 1 1 1 *

3. A boardslide is a common trick where a skateboarder uses the middle of the skateboard to slide along a horizontal rail.



The skateboarder and board have a combined mass of 65 kg.

- (a) At the start of the rail, the speed of the skateboarder and board is 7.0 m s^{-1} .
 At the end of the rail, the speed of the skateboarder and board is 3.0 m s^{-1} .
- (i) Determine the decrease in kinetic energy as the skateboarder and board slide along the length of the rail.

4

Space for working and answer



3. (a) (continued)

(ii) The length of the rail is 2.0 m.

Calculate the average frictional force between the rail and the skateboard.

3

Space for working and answer

(b) The skateboarder and board slide off the end of the rail.

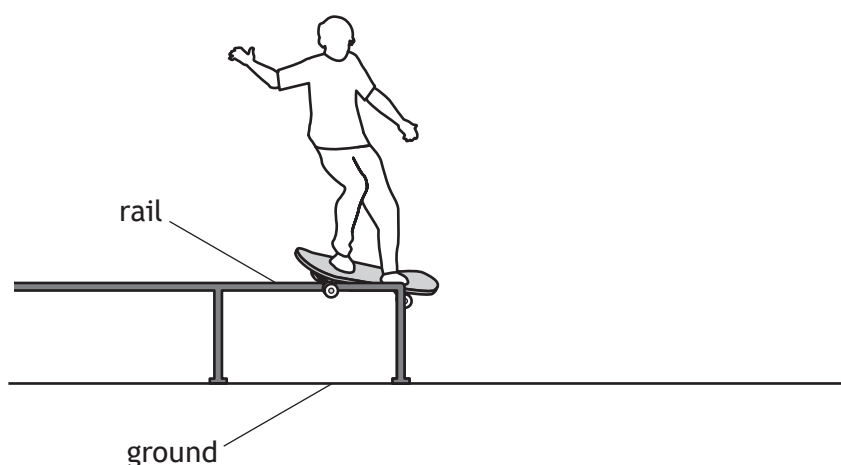

On the diagram above, sketch the path of the skateboarder and board between leaving the rail and reaching the ground.

1

(An additional diagram, if required, can be found on *page 46.*)

[Turn over



* X 8 5 7 7 5 0 1 1 3 *

4. NASA is planning a crewed mission to the Moon.

(a) Part of the mission includes placing a spacecraft in orbit at an altitude of 140 km above the surface of the Moon.

The graph shows the gravitational field strength at different altitudes above the surface of the Moon.

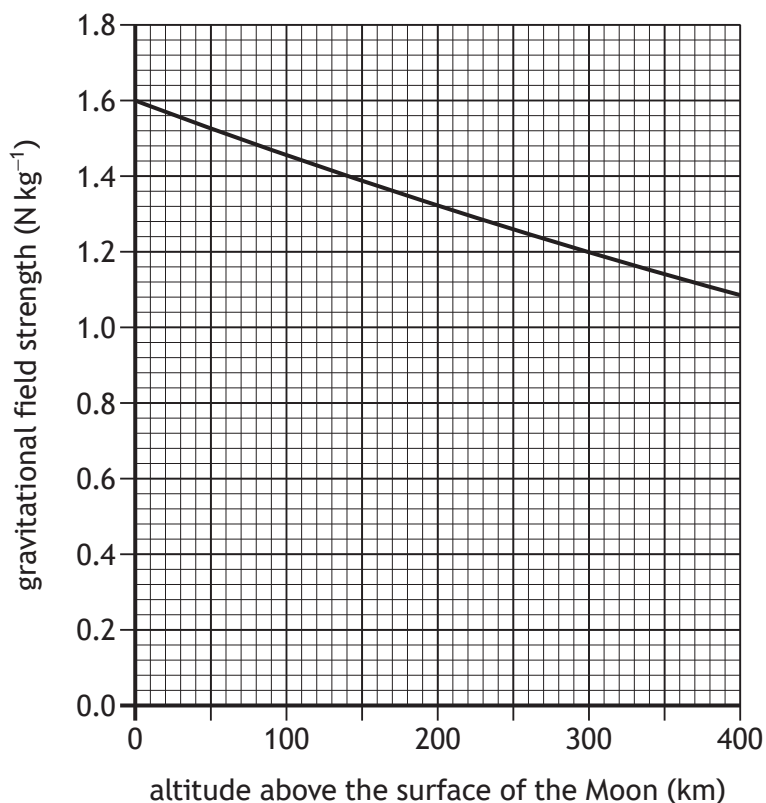

One of the astronauts selected for the mission has a mass of 67 kg.

Calculate the weight of this astronaut when they are at an altitude of 140 km above the surface of the Moon.

3

Space for working and answer



4. (continued)

- (b) Once the spacecraft is in orbit, some of the astronauts will travel to the surface of the Moon in a transportation module.

These astronauts will remain on the surface of the Moon for approximately one week.

Describe one physics-related challenge these astronauts will face while on the surface of the Moon.

1

- (c) After spending time on the Moon, the astronauts will return to the orbiting spacecraft using the transportation module.

During the first part of this return journey, the rockets on the transportation module will exert a constant upward force.

State what will happen to the acceleration of the transportation module during this part of the journey.

You must justify your answer.

3

[Turn over



* X 8 5 7 7 5 0 1 1 5 *

5. Around 500 years ago Nicolaus Copernicus, a Polish astronomer, proposed a model of the Universe with the Sun motionless at its centre and the stars fixed in position in the night sky.

Using your knowledge of physics, comment on this model.

3



* X 8 5 7 7 5 0 1 1 6 *

5. (continued)

[Turn over



* X 8 5 7 7 5 0 1 1 7 *

6. Launched in 2022, the James Webb Space Telescope (JWST) is the world's premier space-based science observatory.
The NASA website states that the JWST will solve mysteries in our Solar System and probe the mysterious structures and origins of our Universe.
- (a) State an advantage of using a space-based telescope compared to ground-based telescopes. 1
- (b) In 2023, the JWST was used to study the exoplanet LHS 475 b.
- (i) State what is meant by the term *exoplanet*. 1
- (ii) LHS 475 b orbits a star in the constellation Octans.
The star is 41 light-years from Earth.
Determine the distance, in metres, from this star to Earth. 3
Space for working and answer



* X 8 5 7 7 5 0 1 1 8 *

6. (continued)

- (c) The line spectrum from a star is shown, along with the line spectra of the elements hydrogen, helium, mercury, and nitrogen.

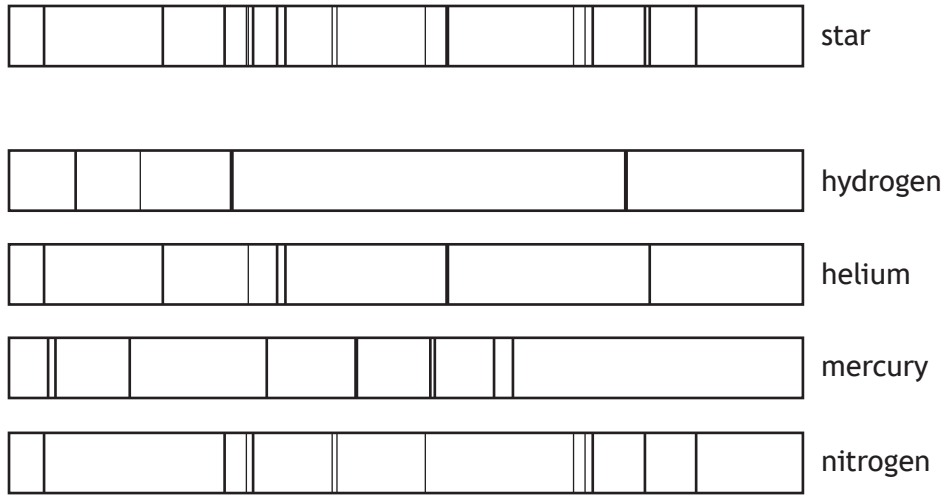

Determine which of these elements are present in the star.

1

[Turn over



7. A wireless charger uses radio waves to charge the battery of a mobile phone.

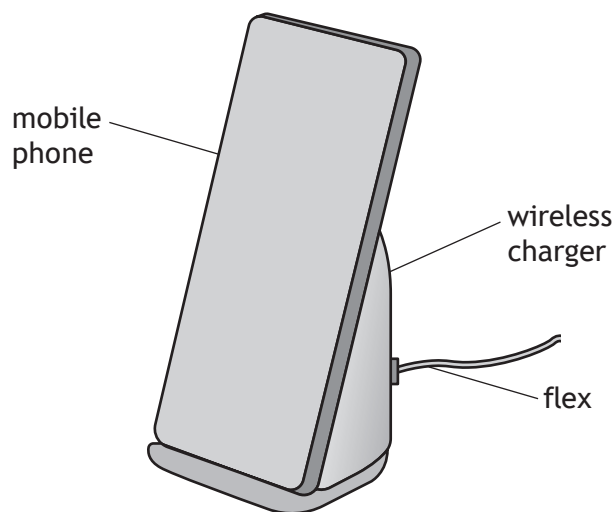

(a) The charger is connected to a direct current (d.c.) supply via a flex.
Explain in terms of electron flow what is meant by *direct current*.

1

(b) The current in the flex is 2.5 A.
The charger is in use for 1.5 hours.
Calculate the charge supplied to the charger during this time.
Space for working and answer

3



7. (continued)

(c) During use the charger heats up.

The charger contains a fan that switches on automatically when the temperature of the charger increases above a certain level.

Part of the circuit containing the fan is shown.

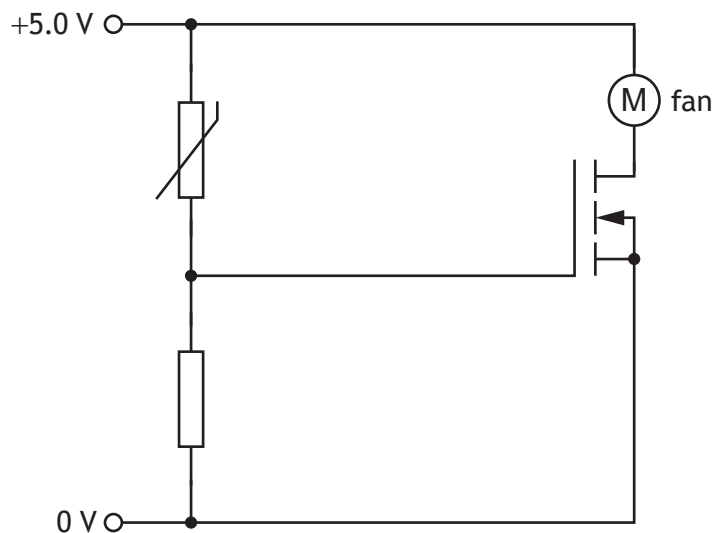

As the temperature of the charger increases, the resistance of the thermistor decreases.

Explain how the circuit operates to switch on the fan when the temperature of the charger increases above a certain level.

3

[Turn over



7. (continued)

- (d) Once the mobile phone is fully charged, an LED on the charger lights. Part of the circuit containing the LED is shown.

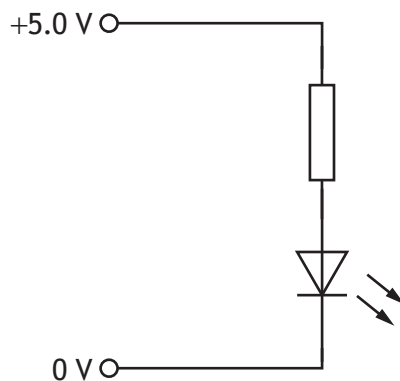

The voltage across the LED is 2.2 V and the current in the LED is 18 mA.

Determine the resistance of the resistor in series with the LED.

Space for working and answer

4



[Turn over for next question

DO NOT WRITE ON THIS PAGE



* X 8 5 7 7 5 0 1 2 3 *

8. A student sets up the following circuit to investigate the relationship between the current in and the voltage across a lamp.

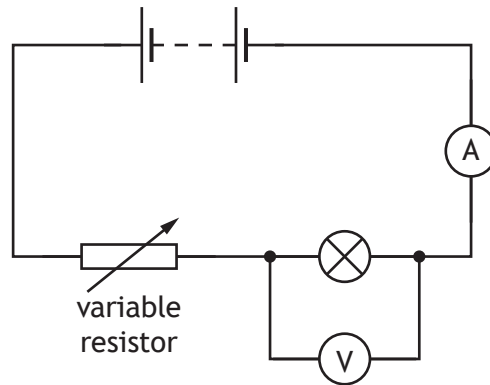

The student uses the circuit to obtain a range of measurements of current in the lamp and voltage across the lamp.

The measurements taken by the student are shown in the table.

Current (A)	Voltage (V)
0.20	0.8
0.40	2.3
0.60	4.9
0.80	8.6
0.90	11.0



8. (continued)

- (a) (i) Using the graph paper, draw a graph of the student's results.
 (Additional graph paper, if required, can be found on *page 46.*)

3

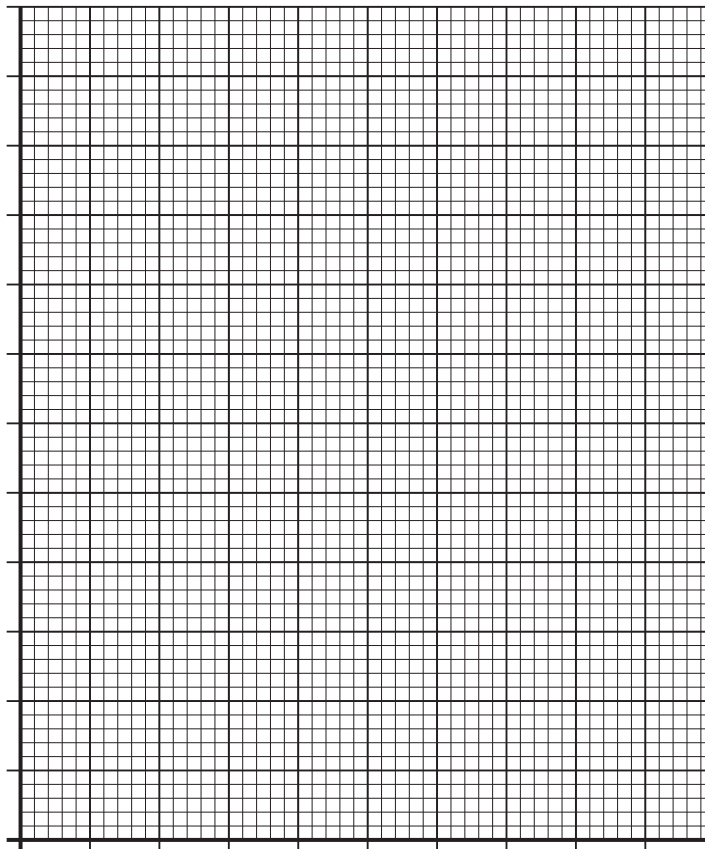

- (ii) Use your graph to determine the voltage across the lamp when the current in the lamp is 0.70 A.

1

- (iii) Describe how the student obtained a range of values of current and voltage using **this** circuit.

1



8. (continued)

- (b) The student then replaces the lamp in the circuit with a fixed resistor and repeats the investigation.

Using the axes below, sketch a graph to show how the voltage V across the fixed resistor varies with the current I in the circuit.

(An additional diagram, if required, can be found on *page 47*.)

1

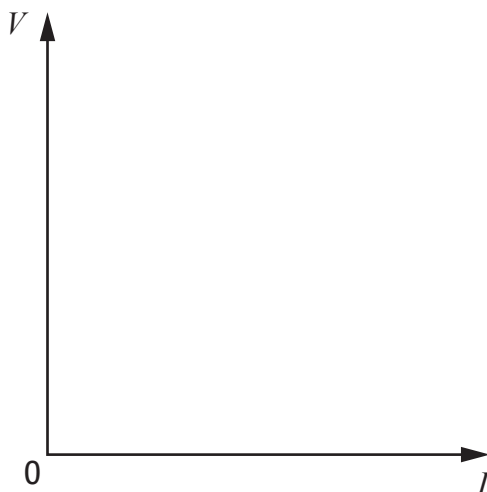

[Turn over for next question

DO NOT WRITE ON THIS PAGE



* X 8 5 7 7 5 0 1 2 7 *

9. Bottles used for feeding babies require sterilising before use.

For one design of bottle, a microwave oven is used to heat water in the bottle. This produces steam, which sterilises the bottle.

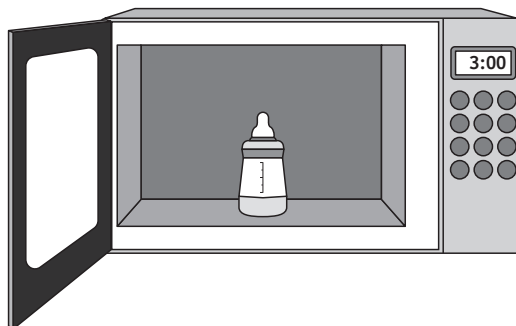

To sterilise the bottle, 0.020 kg of water is placed in the base of the bottle, before being heated in the microwave oven.

- (a) The initial temperature of the water is 6.3 °C.

- (i) Calculate the energy required to heat the water to its boiling point. 3

Space for working and answer

- (ii) During heating, 0.014 kg of water is changed to steam.

Calculate the energy required to change 0.014 kg of water at its boiling point to steam. 3

Space for working and answer



* X 8 5 7 7 5 0 1 2 8 *

9. (a) (continued)

- (iii) Determine the minimum energy required to produce 0.014 kg of steam from 0.020 kg of water at an initial temperature of 6.3 °C.

1

Space for working and answer

- (b) The microwave oven has a power rating of 750 W.

The microwave oven is switched on for 180 s in order to sterilise the bottle.

- (i) Calculate the total energy used by the microwave oven during this time.

3

Space for working and answer

- (ii) Explain why the total energy used by the microwave oven during this time is different to the minimum energy required to produce the steam determined in (a) (iii).

1

[Turn over



* X 8 5 7 7 5 0 1 2 9 *

10. A cyclist inflates the tyres on their bike before going cycling.



- (a) The cyclist inflates a tyre to a pressure of 655 kPa.
The temperature of the gas inside the tyre is 21 °C.
At one point in the journey the temperature of the gas inside the tyre is 14 °C.
The mass of gas and the volume of gas inside the tyre remain constant.
- (i) Determine the pressure of the gas inside the tyre at a temperature of 14 °C.

Space for working and answer

3



10. (a) (continued)

(ii) Explain, using the kinetic model, how the decrease in temperature affects the pressure of the gas inside the tyre.

3

(b) At one point, the cyclist stops pedalling and freewheels.



The tyres have a total contact area with the ground of $7.5 \times 10^{-4} \text{ m}^2$ and exert a pressure of $1.02 \times 10^6 \text{ Pa}$ on the ground.

Determine the total mass of the cyclist and bike.

4

Space for working and answer



11. A wave energy converter is a machine anchored to the seabed that changes the kinetic energy of water waves into electrical energy.

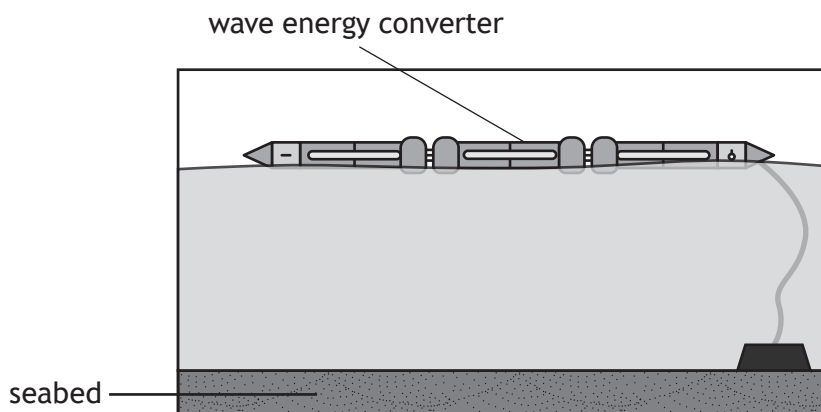

- (a) Water waves are transverse waves.

State what is meant by the term *transverse wave*.

1

- (b) An engineer uses a stopwatch to measure the time taken for one complete wave to pass the end of the converter.

The stopwatch is started when a crest passes the end of the converter and stopped when the next crest passes.

The time measured by the engineer is 7.4 s.

- (i) Calculate the frequency of the waves.

3

Space for working and answer



11. (b) (continued)

- (ii) Suggest how the accuracy of the frequency of the waves determined by the engineer could be improved.

1

- (c) The average electrical power produced by the converter depends on the wave height.

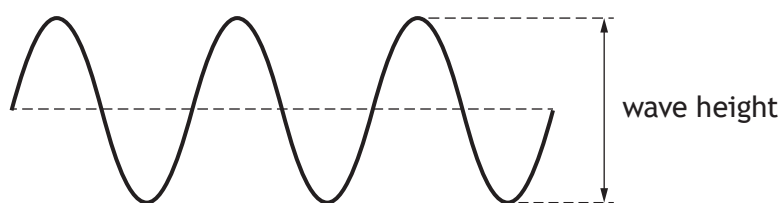

The graph shows how the average electrical power produced by the convertor varies with wave height.

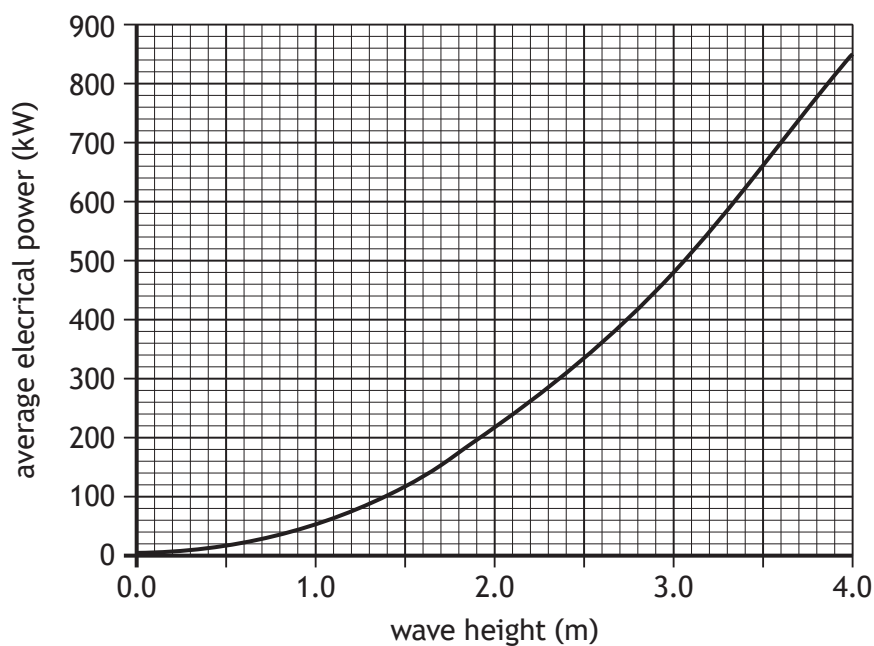

Use the graph to determine the average electrical power produced by the converter when the **amplitude** of the waves is 1.5 m.

1



* X 8 5 7 7 5 0 1 3 3 *

11. (continued)

- (d) The wave energy converter is now moved to a position behind a harbour wall, so it can be serviced.

Waves travel towards the harbour wall, as shown.

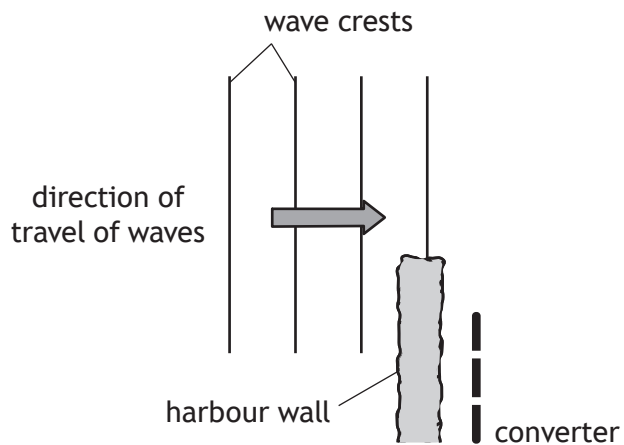

Complete the diagram to show the pattern of the wave crests beyond the harbour wall.

(An additional diagram, if required, can be found on *page 47*.)

2



[Turn over for next question

DO NOT WRITE ON THIS PAGE



* X 8 5 7 7 5 0 1 3 5 *

12. While at a firework display, a student sees a flash and hears a bang from each firework explosion.



The student states:

'Measuring the time between seeing a flash and hearing a bang will allow me to calculate the distance to the firework when it explodes.'

- (a) State what additional information is required to calculate the distance between the student and the firework when it explodes.

1

- (b) The student takes a picture of a firework exploding using their mobile phone. The firework produces red light.

The camera in the mobile phone uses a glass lens to focus rays of the red light onto a sensor as shown.

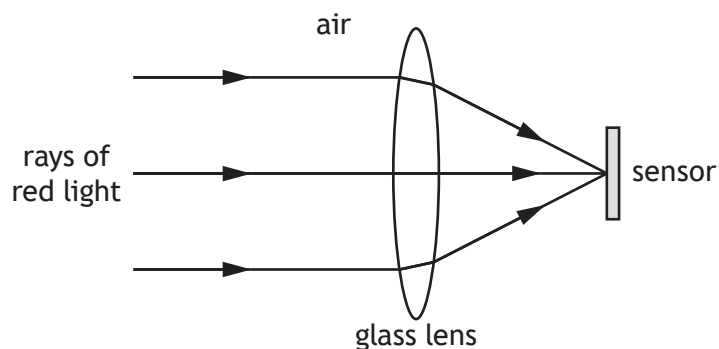

12. (b) (continued)

(i) Explain why the ray of red light passing through the centre of the lens does not change direction.

1

(ii) State whether the frequency of the red light in the lens is less than, equal to or greater than the frequency of the red light in air.

1

(c) At one point during the display the student moves to a position near a tall building and, as a result, now hears two bangs from each firework explosion.

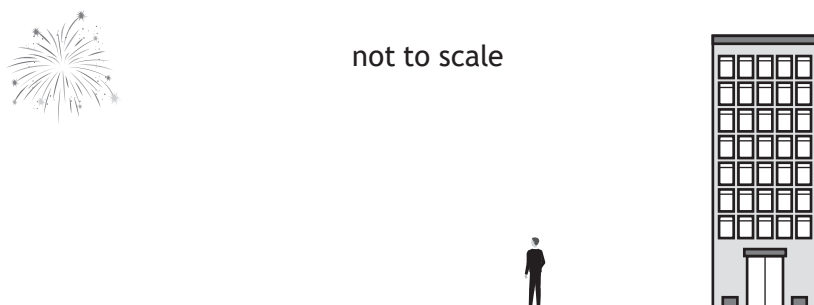

State how the amplitude of the second bang from each explosion heard by the student compares to the amplitude of the first bang from each explosion heard by the student.

You must justify your answer.

2

[Turn over



13. Two students are discussing radiation.

The first student states: *'All radiation is dangerous, so we should never allow ourselves to be exposed to it.'*

The second student states: *'No, it's only nuclear radiation that we need to worry about.'*

Using your knowledge of physics, comment on the students' statements.

3



* X 8 5 7 7 5 0 1 3 8 *

13. (continued)

[Turn over



* X 8 5 7 7 5 0 1 3 9 *

14. Medical face masks can be sterilised using gamma radiation to kill bacteria. The masks are placed into sealed plastic packages. These packages are then placed in a steriliser where they are exposed to gamma radiation.

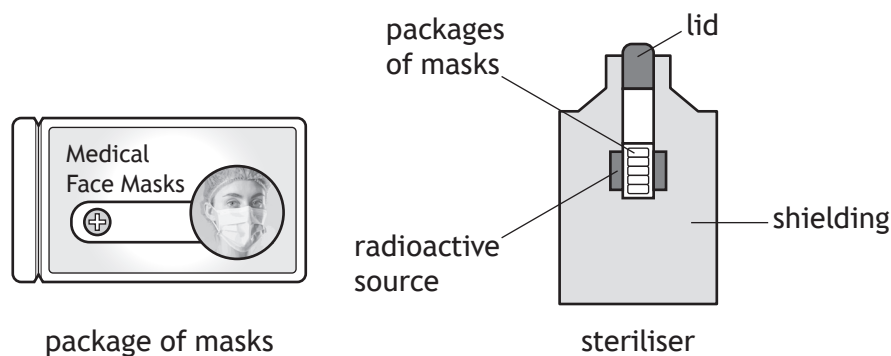

- (a) The gamma radiation is produced by a cobalt-60 source. The source has an initial activity of 848 000 GBq. The half-life of cobalt-60 is 5.3 years. Determine the activity of the source 21.2 years later. *Space for working and answer*

3



14. (continued)

- (b) The face masks receive an absorbed dose of 25 kGy to ensure that they are safe for use.

The mass of each face mask is 2.2×10^{-3} kg.

- (i) The masks receive an absorbed dose of 0.50 Gy each second.

Determine the length of time, in seconds, that the masks remain in the steriliser.

1

Space for working and answer

- (ii) Calculate the energy absorbed by each face mask.

3

Space for working and answer

[Turn over



* X 8 5 7 7 5 0 1 4 1 *

15. Read the passage and answer the questions that follow.

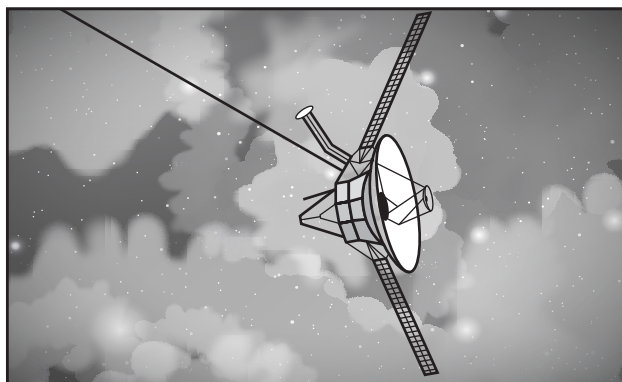

Spacecraft travelling to distant parts of the Solar System need to have a source of power to operate their electrical systems.

Many spacecraft use solar cells to generate electricity, but this is not always suitable.

Some spacecraft, such as Voyager 2, are powered using energy generated by Radioisotope Thermoelectric Generators (RTGs). The RTGs in Voyager 2 use plutonium-238 as a fuel. The half-life of plutonium-238 is 88 years. The plutonium decays to uranium in a nuclear fission reaction. The heat generated by this radioactive decay is then converted into electrical energy.

In the future, NASA plans to equip spacecraft with miniature nuclear reactors, which use nuclear fission chain reactions to generate power.

(a) Explain why solar cells may not be a suitable source of power when exploring distant parts of the Solar System.

1

(b) Explain why the decay of plutonium to uranium is described as a nuclear fission reaction.

1



15. (continued)

(c) Describe the role of neutrons in a nuclear fission **chain reaction**.

2

(d) Voyager 2 has been travelling through space for nearly 50 years.

Explain why the power output of the RTGs on Voyager 2 have decreased over this time.

1

[END OF QUESTION PAPER]



* X 8 5 7 7 5 0 1 4 3 *

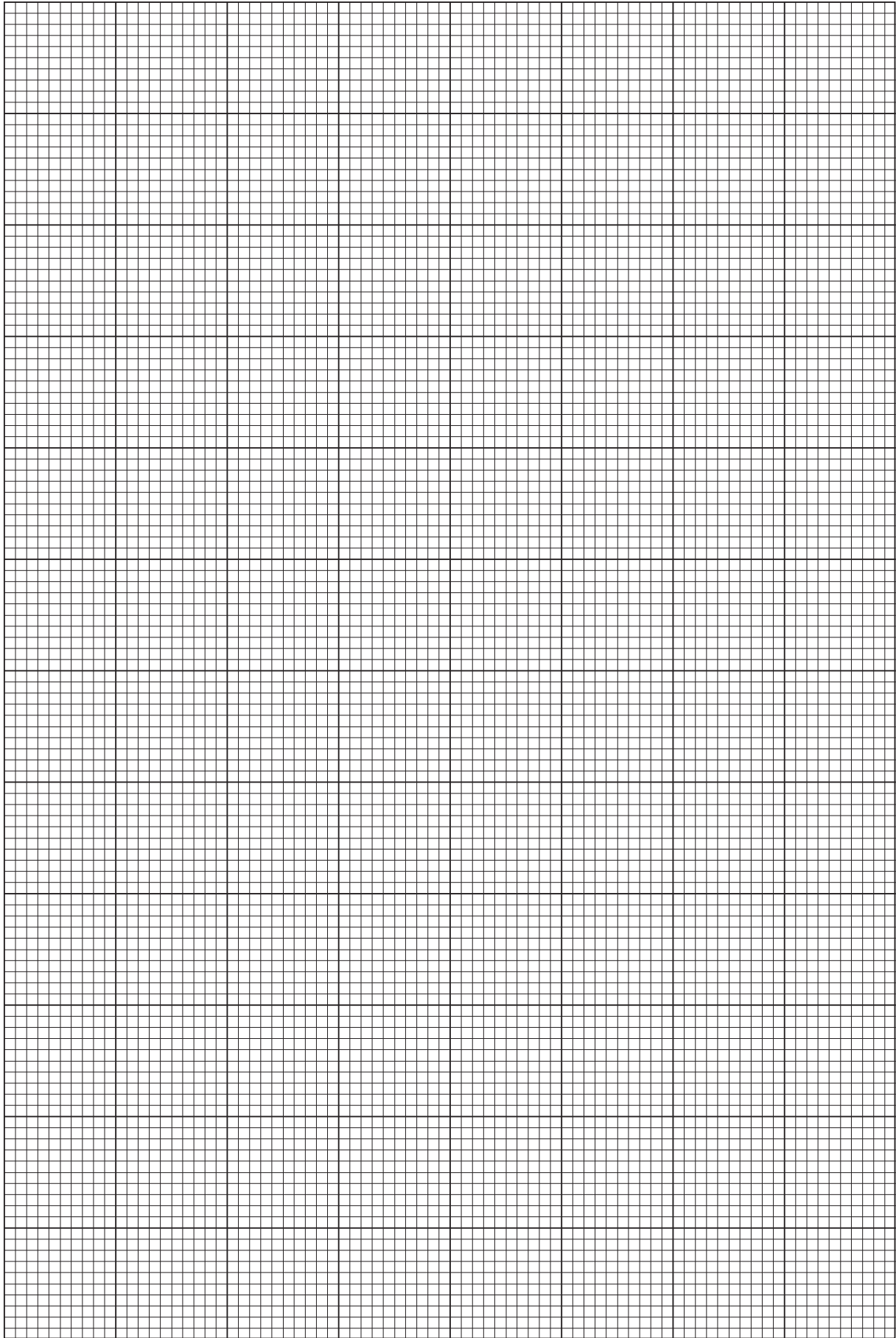

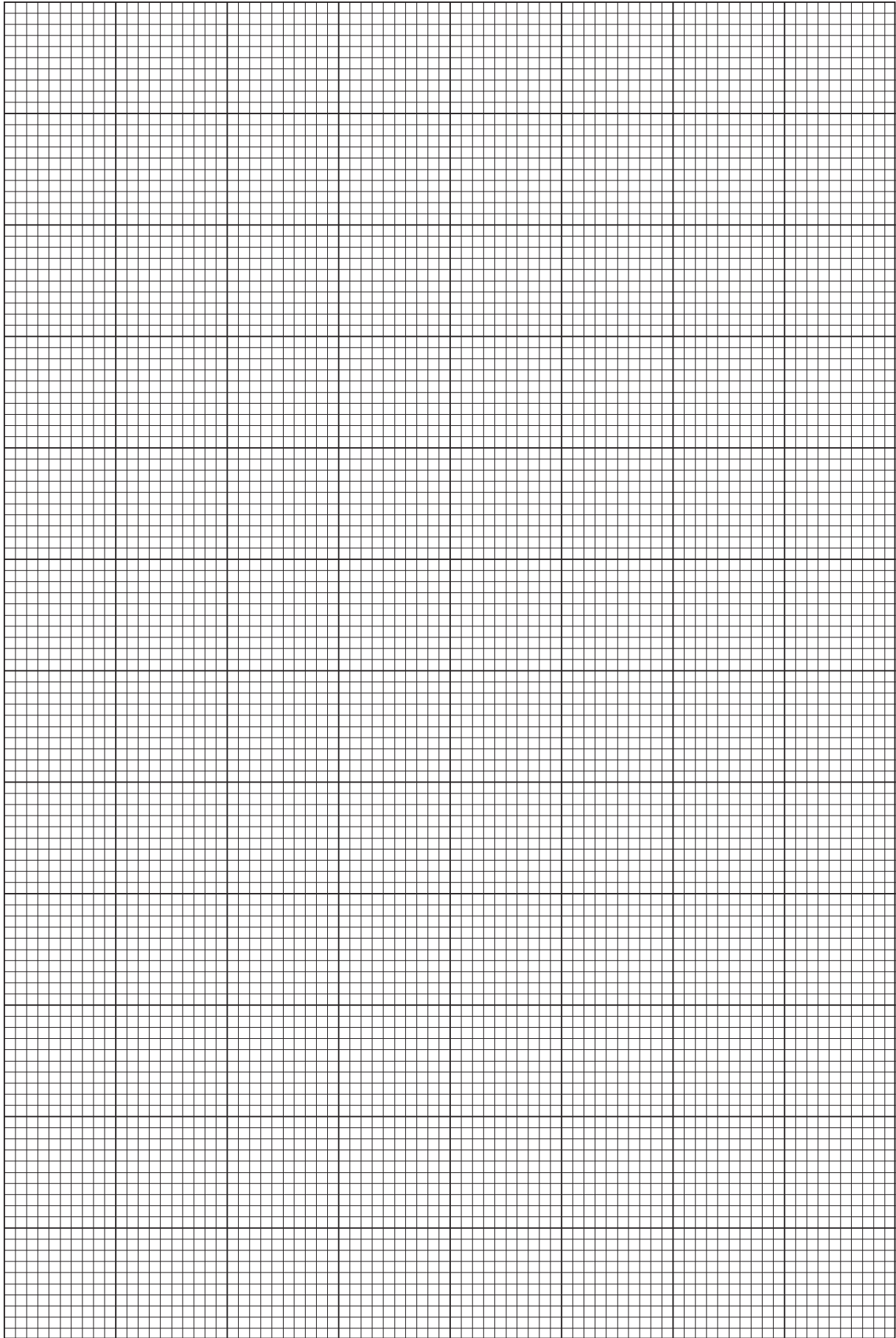

ADDITIONAL SPACE FOR ANSWERS AND ROUGH WORK

Additional diagram for use with question 3 (b)

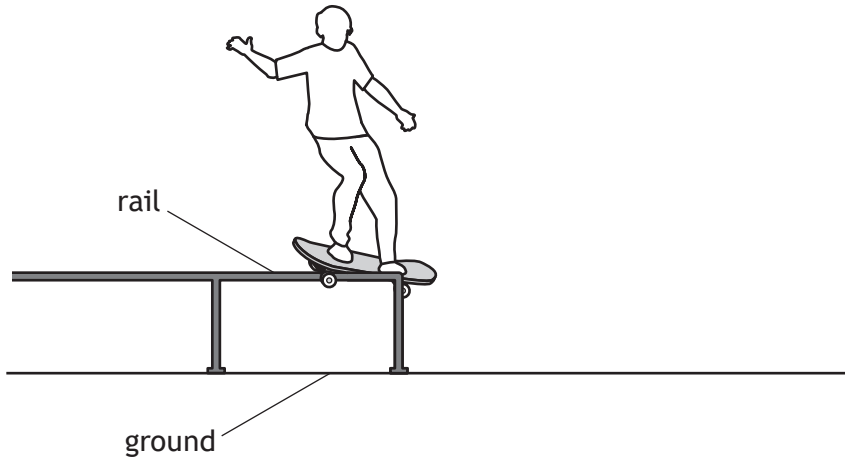

Additional graph paper for use with question 8 (a) (i)

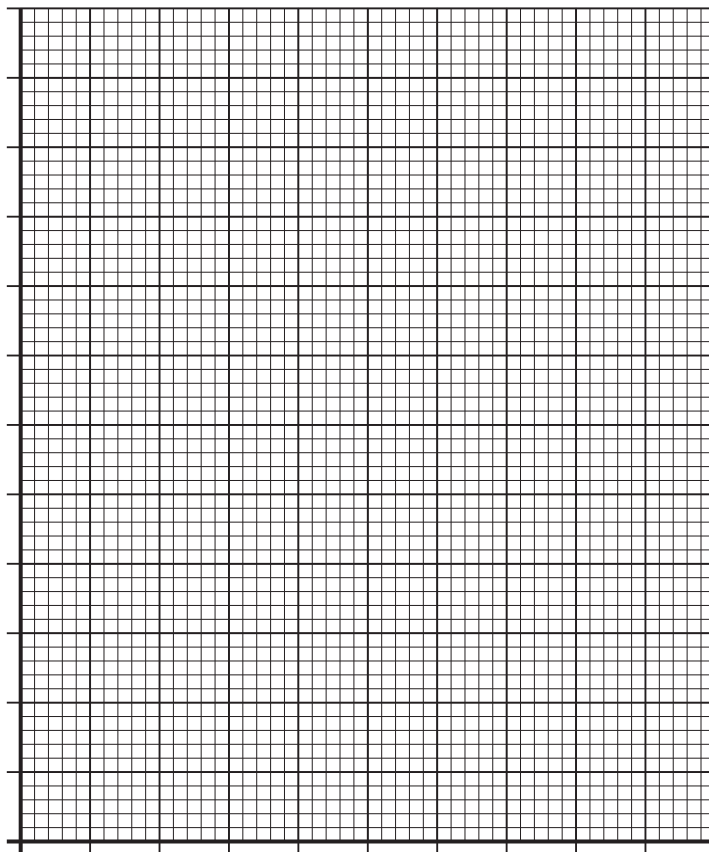

ADDITIONAL SPACE FOR ANSWERS AND ROUGH WORK

Additional graph for use with question 8 (b)

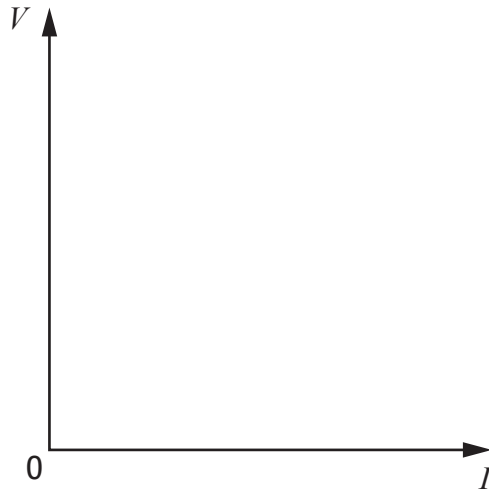

Additional diagram for use with question 11 (d)

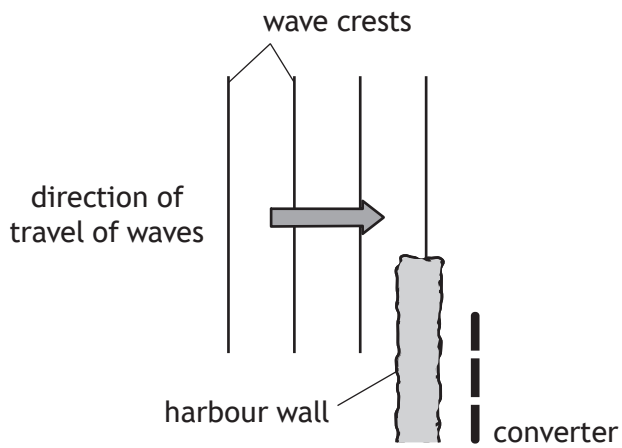

MARKS DO NOT
WRITE IN
THIS
MARGIN

ADDITIONAL SPACE FOR ANSWERS AND ROUGH WORK



* X 8 5 7 7 5 0 1 4 8 *

MARKS DO NOT
WRITE IN
THIS
MARGIN

ADDITIONAL SPACE FOR ANSWERS AND ROUGH WORK



* X 8 5 7 7 5 0 1 4 9 *

MARKS DO NOT
WRITE IN
THIS
MARGIN

ADDITIONAL SPACE FOR ANSWERS AND ROUGH WORK



* X 8 5 7 7 5 0 1 5 0 *

[BLANK PAGE]

DO NOT WRITE ON THIS PAGE



* X 8 5 7 7 5 0 1 5 1 *

[BLANK PAGE]

DO NOT WRITE ON THIS PAGE

Acknowledgement of copyright

Question 3 guteksk7/shutterstock.com
Question 10 Friends Stock/shutterstock.com
Question 12 Yaorusheng/shutterstock.com
Question 14 Maha Heang 245789/shutterstock.com



* X 8 5 7 7 5 0 1 5 2 *