



National
Qualifications
2025

X857/75/02

Physics
Section 1 — Questions

THURSDAY, 15 MAY

1:00 PM – 3:30 PM

Instructions for the completion of Section 1 are given on *page 02* of your question and answer booklet X857/75/01.

Record your answers on the answer grid on *page 03* of your question and answer booklet.

Reference may be made to the data sheet on *page 02* of this booklet and to the relationships sheet X857/75/11.

Before leaving the examination room you must give your question and answer booklet to the Invigilator; if you do not, you may lose all the marks for this paper.



* X 8 5 7 7 5 0 2 *

DATA SHEET

Speed of light in materials

Material	Speed in m s^{-1}
Air	3.0×10^8
Carbon dioxide	3.0×10^8
Diamond	1.2×10^8
Glass	2.0×10^8
Glycerol	2.1×10^8
Water	2.3×10^8

Gravitational field strengths

	Gravitational field strength on the surface in N kg^{-1}
Earth	9.8
Jupiter	23
Mars	3.7
Mercury	3.7
Moon	1.6
Neptune	11
Saturn	9.0
Sun	270
Uranus	8.7
Venus	8.9

Specific latent heat of fusion of materials

Material	Specific latent heat of fusion in J kg^{-1}
Alcohol	0.99×10^5
Aluminium	3.95×10^5
Carbon dioxide	1.80×10^5
Copper	2.05×10^5
Iron	2.67×10^5
Lead	0.25×10^5
Water	3.34×10^5

Specific latent heat of vaporisation of materials

Material	Specific latent heat of vaporisation in J kg^{-1}
Alcohol	11.2×10^5
Carbon dioxide	3.77×10^5
Glycerol	8.30×10^5
Turpentine	2.90×10^5
Water	22.6×10^5

Speed of sound in materials

Material	Speed in m s^{-1}
Aluminium	5200
Air	340
Bone	4100
Carbon dioxide	270
Glycerol	1900
Muscle	1600
Steel	5200
Tissue	1500
Water	1500

Specific heat capacity of materials

Material	Specific heat capacity in $\text{J kg}^{-1} \text{ }^\circ\text{C}^{-1}$
Alcohol	2350
Aluminium	902
Copper	386
Glass	500
Ice	2100
Iron	480
Lead	128
Oil	2130
Water	4180

Melting and boiling points of materials

Material	Melting point in $^\circ\text{C}$	Boiling point in $^\circ\text{C}$
Alcohol	-98	65
Aluminium	660	2470
Copper	1077	2567
Lead	328	1737
Iron	1537	2737
Water	-	100

Radiation weighting factors

Type of radiation	Radiation weighting factor
alpha	20
beta	1
fast neutrons	10
gamma	1
slow neutrons	3
X-rays	1

SECTION 1 — 25 marks

Attempt ALL questions

1. Which row in the table shows both quantities classified correctly?

	Scalar	Vector
A	weight	force
B	distance	velocity
C	mass	distance
D	force	mass
E	velocity	time

2. The graph shows how the velocity v of an object varies with time t .

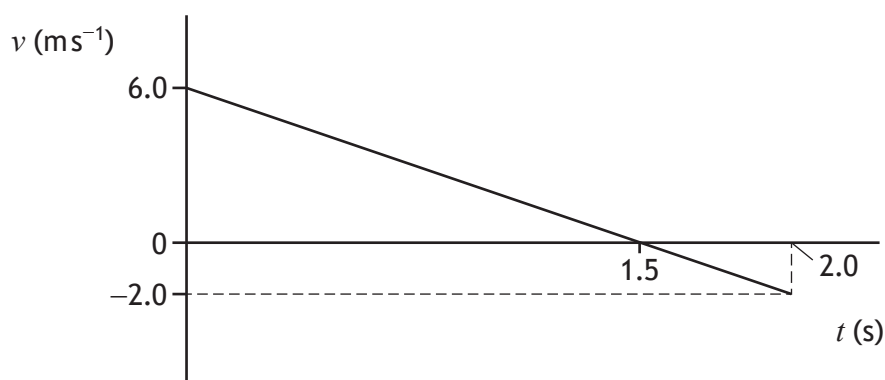

The displacement of the object at 2.0 seconds is

- A 4.0 m
- B 5.0 m
- C 6.0 m
- D 8.0 m
- E 10.0 m.

[Turn over

3. A car is travelling along a straight level road.
The car slows down at a constant rate of 2.0 m s^{-2} for a time of 8.0 s .
The final speed of the car is 5.0 m s^{-1} .
The initial speed of the car is

- A 7.0 m s^{-1}
- B 11 m s^{-1}
- C 16 m s^{-1}
- D 21 m s^{-1}
- E 80 m s^{-1} .

4. A cup rests on a table that rests on the Earth. The cup exerts a downward force on the table.

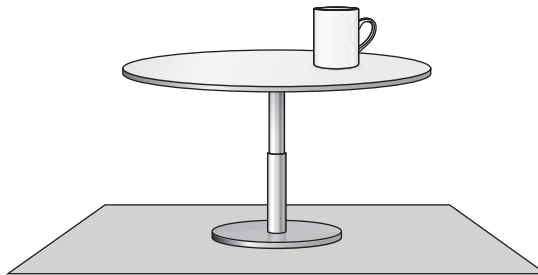

Which of the following is the reaction to this force?

- A The force of the table on the cup
 - B The force of the cup on the Earth
 - C The force of the Earth on the cup
 - D The force of the cup on the table
 - E The force of the table on the Earth
5. A crate of mass 180 kg is lifted through a height of 3.0 m in 2.5 s .
The minimum work done in lifting the crate through this height is
- A 60 J
 - B 540 J
 - C 1800 J
 - D 2200 J
 - E 5300 J .

6. An asteroid of mass 25 kg is travelling at a speed of 9200 m s^{-1} .
On entering the Earth's atmosphere, the asteroid burns up completely.
The maximum amount of heat energy released is

- A $1.2 \times 10^5 \text{ J}$
- B $2.3 \times 10^5 \text{ J}$
- C $2.9 \times 10^6 \text{ J}$
- D $1.1 \times 10^9 \text{ J}$
- E $2.1 \times 10^9 \text{ J}$.

7. The speed v of a satellite in orbit around the Earth is given by the relationship

$$v = \sqrt{rg}$$

where: r is the total distance from the centre of the Earth to the satellite in m
 g is the gravitational field strength at the location of the satellite in N kg^{-1} .

The radius of the Earth is $6.4 \times 10^6 \text{ m}$.

The height of a satellite above the surface of the Earth is $3.6 \times 10^7 \text{ m}$.

The gravitational field strength at this height is 0.22 N kg^{-1} .

The speed of the satellite is

- A 1200 m s^{-1}
- B 2800 m s^{-1}
- C 3100 m s^{-1}
- D 7900 m s^{-1}
- E $20\,000 \text{ m s}^{-1}$.

[Turn over

8. The weight of an astronaut on Earth is 710 N.

The weight of the astronaut on Mars is

- A 72 N
- B 190 N
- C 270 N
- D 710 N
- E 2600 N.

9. Sirius is the brightest star in the night sky.

The distance from Earth to Sirius is 8.6 light-years.

This distance is equivalent to

- A 2.7×10^8 m
- B 2.3×10^{13} m
- C 1.4×10^{15} m
- D 9.5×10^{15} m
- E 8.1×10^{16} m.

10. The line spectrum from a star is shown, along with the line spectra of the elements hydrogen, helium, carbon, and nitrogen.

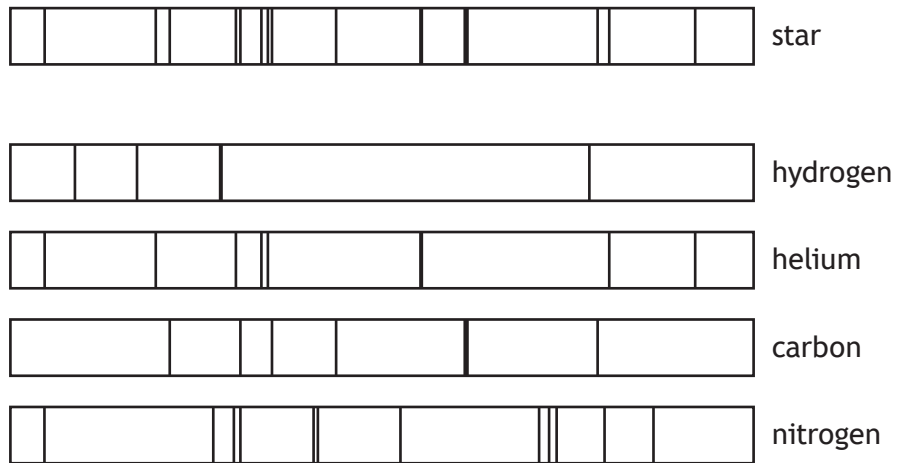

The elements present in this star are

- A hydrogen and helium
- B hydrogen and carbon
- C helium and carbon
- D helium and nitrogen
- E carbon and nitrogen.

[Turn over

11. A technician uses an oscilloscope to test three different power supplies.
The diagrams represent the traces seen on the screen of the oscilloscope.

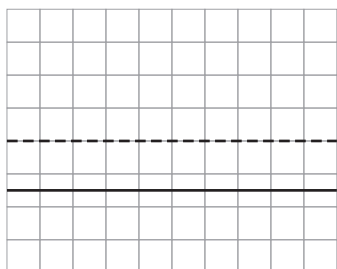

trace X

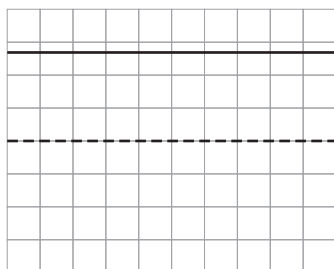

trace Y

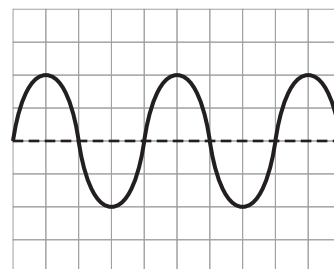

trace Z

Which row in the table identifies trace X, trace Y, and trace Z?

	trace X	trace Y	trace Z
A	d.c.	d.c.	d.c.
B	a.c.	d.c.	d.c.
C	a.c.	a.c.	d.c.
D	a.c.	a.c.	a.c.
E	d.c.	d.c.	a.c.

12. An electric field exists around two point charges Q and R.
 The diagram shows the path taken by a charged particle as it travels through the field.
 The motion of the particle is as shown.



Which row in the table identifies the charge on the particle, the charge on Q, and the charge on R?

	Charge on particle	Charge on Q	Charge on R
A	positive	negative	negative
B	negative	negative	positive
C	negative	positive	negative
D	positive	negative	positive
E	positive	positive	positive

[Turn over

13. A circuit is set up as shown.

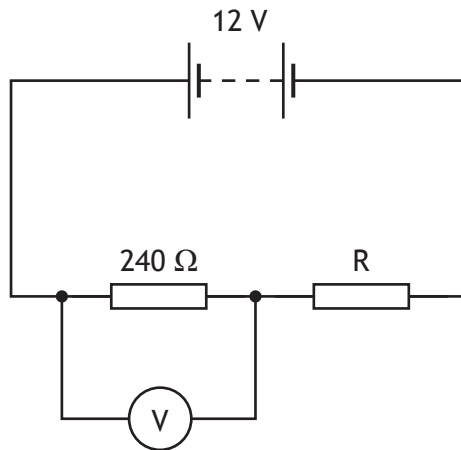

The reading on the voltmeter is 3.0 V.

The resistance of resistor R is

- A 20 Ω
- B 80 Ω
- C 320 Ω
- D 720 Ω
- E 960 Ω.

14. Three resistors are connected as shown.

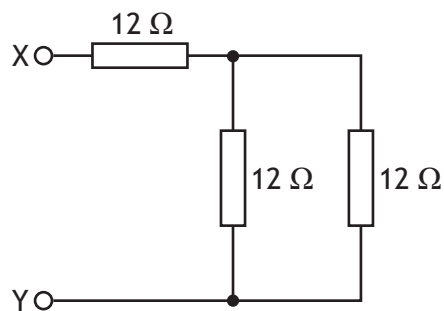

The total resistance between X and Y is

- A 4 Ω
- B 6 Ω
- C 8 Ω
- D 18 Ω
- E 36 Ω.

15. A circuit is set up as shown.

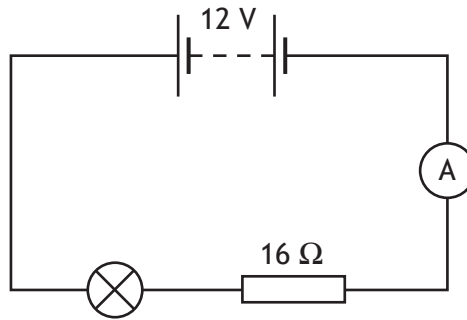

The reading on the ammeter is 0.50 A.

The resistance of the lamp is 8.0Ω .

The power dissipated in the lamp is

- A 2.0 W
- B 4.0 W
- C 6.0 W
- D 9.0 W
- E 18 W.

[Turn over

16. A kettle, a television, and a microwave are connected to the mains supply.

The kettle has a power rating of 2.6 kW.

The television has a power rating of 170 W.

The microwave has a power rating of 900 W.

Which row in the table shows the appropriate fuse rating for the kettle, the television, and the microwave?

	Appropriate fuse rating for kettle (A)	Appropriate fuse rating for television (A)	Appropriate fuse rating for microwave (A)
A	3	13	3
B	13	3	13
C	13	13	3
D	3	3	13
E	13	3	3

17. A group of students sets up the experiment shown to determine a value for the specific heat capacity of water.

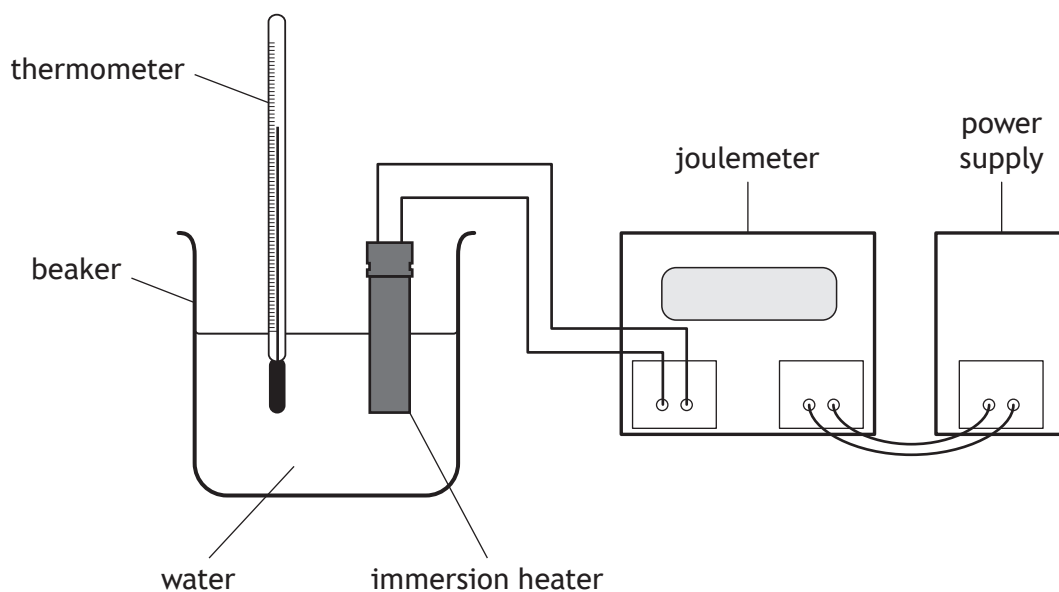

The students make the following statements about how the experimental procedure could be improved.

- I Insulate the beaker to reduce heat lost to the surroundings.
- II Move the immersion heater further into the water.
- III Use a stopwatch to measure the time for which the water is heated.

Which of these statements is/are correct?

- A I only
- B II only
- C I and II only
- D I and III only
- E I, II and III

[Turn over

18. A hot substance is cooled.

The graph shows how the temperature of the substance changes with time.

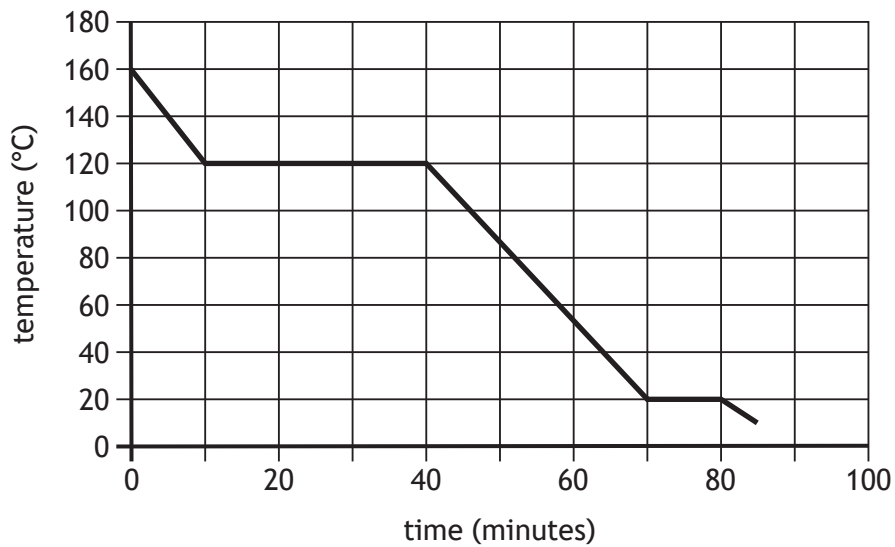

A student makes the following statements about the substance.

- I The boiling point of the substance is 120 °C.
- II At a time of 40 minutes, the substance is a gas.
- III The melting point of the substance is 20 °C.

Which of these statements is/are correct?

- A I only
- B II only
- C I and III only
- D II and III only
- E I, II and III

19. A ballet dancer wears shoes that have a flat section on the front called a platform.
When the ballet dancer stands on the tips of their toes, the platform on each shoe is flat on the floor.

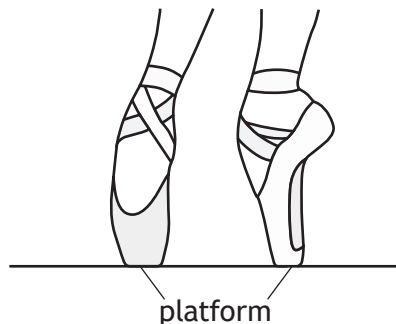

The area of the platform on each shoe is $1.6 \times 10^{-3} \text{ m}^2$.
The weight of the ballet dancer is 520 N.
The pressure exerted on the floor by the ballet dancer is

- A $3.1 \times 10^{-6} \text{ Pa}$
B $6.2 \times 10^{-6} \text{ Pa}$
C $8.3 \times 10^{-1} \text{ Pa}$
D $1.6 \times 10^5 \text{ Pa}$
E $3.3 \times 10^5 \text{ Pa}$.
20. A tennis ball contains a fixed mass of air at a temperature of $20.0 \text{ }^\circ\text{C}$.
The pressure of the air inside the ball is $1.90 \times 10^5 \text{ Pa}$.
During a tennis match the temperature of the air inside the ball rises to $35.0 \text{ }^\circ\text{C}$.
The volume of the air remains constant.
The pressure of the air inside the ball is now
- A $1.09 \times 10^5 \text{ Pa}$
B $1.81 \times 10^5 \text{ Pa}$
C $1.87 \times 10^5 \text{ Pa}$
D $2.00 \times 10^5 \text{ Pa}$
E $3.33 \times 10^5 \text{ Pa}$.

[Turn over

21. The diagram represents a wave.

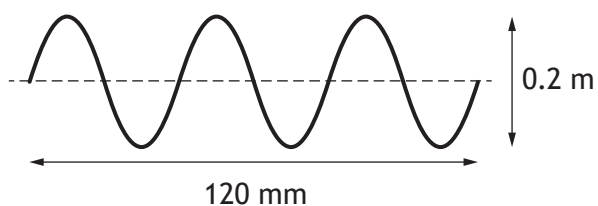

Which row in the table shows the wavelength and amplitude of the wave?

	Wavelength (mm)	Amplitude (m)
A	20	0.1
B	40	0.1
C	40	0.2
D	120	0.1
E	120	0.2

22. A teacher gives a group of students two clues to identify a particular band of the electromagnetic spectrum.

Clue 1: Diffracts around obstacles more than visible light.

Clue 2: Has a greater frequency than microwave radiation.

The band of the electromagnetic spectrum these clues refer to is

- A gamma rays
- B infrared
- C ultraviolet
- D radio
- E X-rays.

23. A radioactive source has an average activity of 5.2 MBq over a time of 1.2 hours.
The number of nuclear disintegrations that occur in the source in this time is
- A 1.2×10^3
 - B 4.3×10^6
 - C 6.2×10^6
 - D 3.7×10^8
 - E 2.2×10^{10} .
24. A sample of tissue is exposed to a source of alpha particles.
The equivalent dose received from this source during a time of 5 minutes is 480 μSv .
The equivalent dose rate is
- A $1.6 \mu\text{Sv s}^{-1}$
 - B $96 \mu\text{Sv s}^{-1}$
 - C $2400 \mu\text{Sv s}^{-1}$
 - D $9600 \mu\text{Sv s}^{-1}$
 - E $144\,000 \mu\text{Sv s}^{-1}$.
25. Energy is released when two small nuclei combine during a nuclear reaction to form a larger nucleus.
This is a description of
- A nuclear fission
 - B nuclear fusion
 - C alpha decay
 - D beta decay
 - E gamma emission.

[END OF SECTION 1. NOW ATTEMPT THE QUESTIONS IN SECTION 2 OF
YOUR QUESTION AND ANSWER BOOKLET]

[BLANK PAGE]

DO NOT WRITE ON THIS PAGE

[BLANK PAGE]

DO NOT WRITE ON THIS PAGE

[BLANK PAGE]

DO NOT WRITE ON THIS PAGE